

RESEARCH ARTICLE

Open Access

Investigating Values of Purchase through the Green Image of Store on Impulse Purchase and Customer loyalty

Homa Doroudi ¹, Hadi Mohammadi ²**Abstract**

In consumer behavior, purchase field is an interesting field for marketers and psychologists. This area investigates types of purchase and factors affecting them. In the meantime, in order to succeed in markets, understanding customers' consumption values and their impact on consumers' behavior is one of crucial issues. The aim of this study is to determine the relationship between values of purchase through green image on impulse purchase and customer loyalty. The statistical population in this study consists of customers of purchase centers of Iran in 2024. The number of sample is estimated as 384 people. Regarding the purpose, this study is applied and belongs to descriptive- survey and correlational researches. For data collection standard questionnaire of Irene et al. was used, whose validity is determined by nominal and heuristic method and its reliability was measured by Cronbach's alpha coefficient as 0.87. For data analysis and hypothesis testing by path analysis and structural equation, LISREL software is used. The results show that there is no significant relationship between hedonistic values and materialistic values through green image of store with impulse purchase but there is significant relationship between hedonistic values and materialistic values through green image of store with loyalty.

Keywords: *Value of purchase, Green image, Impulse purchase, Loyalty.*

Introduction

The key point to success of marketing strategy, in terms of both local and global aspects, is understanding consumer behavior. Desirable consumer behaviors refer to the activities that are performed by the customer and lead to the flourishing of the brand and the achievement of its goals in the society (Ebrahimi et al., 2024). This is applicable for businesses and non-profit organizations as well as public organizations that develop laws related to market (Hawkiz, 2010). Good business is based on consumer behavior. A basic concept of marketing is satisfying the needs of consumer behavior. This need can only be met by marketers who want products and services to consumers (Solomon, 2010). **Comment 2:** In this regard, many companies fail to produce products that

meet customer needs and preferences due to a lack of understanding of those needs. This has resulted in a decline in their market share (Nazari Ghazvini et al., 2023). Consumer behavior in today's diverse markets is influenced by various factors, including people's attitudes and perceptions about elements such as the country of manufacture (Jalalzadeh & Momeni, 2024). This research examines consumer choice and buying behavior. One of the most controversial issues in marketing and consumer behavior is the field of consumer's choice and purchase behavior of products in their shop windows and decorating them (Solemani, 2012).

The reason for going purchase of people is that cannot be simply the satisfying desires and experiences to obtain and use the

1*. Department of Business Management, Zanjan Branch, Islamic Azad University, Zanjan, Iran (Corresponding Author: homa_doroudi@yahoo.com)

2. Department of Business Management, Zanjan Branch, Islamic Azad University, Zanjan, Iran

product. Comment 2: On the other hand, customer satisfaction is a complex human process that encompasses cognitive and emotional factors, along with various psychological and physiological effects. This is a critical issue for the success of any traditional or online business (Hosseini et al., 2024). Edward Tapper raised in his short but influencing article. Among the responses received, he identified a number of incentives that were less associated with the act of purchase. These incentives included a set of role-playing, current entertainment of daily life, social experience outside with friends, sensory stimulation and motivation, communication or gossiping with others, interacting with friends group, enjoying the prestige and authority and ultimately the joy of bargaining (Tapper, 2010).

Campbell says purchase is enjoyable activity when one considers it in the circle of voluntary tasks (Falk, blankets, 2011). Customers who follow value of hedonistic purchase mostly seek to have joy and fun of it and describe it a random and aimless matter for their shopping experience (Hirschman, Holbork, 2011).

Impulse purchase is a complex and multifaceted concept (Herkailiglo et al., 2009). Different researchers have different definitions for impulse purchase (Parbuth, 2007). Impulse purchase is one of inclusive aspects of consumer behavior and a significant focal point for activities in marketing. These purchases that operationally are known as unplanned purchases make up between 27 and 62 percent of all store purchases. (Taheri Kia, Nokhbe Zaim, 2012). It is interesting that in Iran, less attention has been paid to the concept of impulse purchase. Therefore, in this study it is tried that this issue be further investigated, so that by identifying its results for developing marketing goals In order to gain customer and loyalty.

In the similar situation, Babin et al. define Hedonic value as perceived emotional and affective value through purchase activities. According to theory of Bruce and Baloch , consumers experience hedonistic value as

experiencing functional or task to the purchase (Baloch, Bruce, 2008). Today, in stores, impulse purchase is a major source of income for them. Today, customers do increasing volume of these purchases that some researchers has studies this phenomenon as a different individual variable recently (Abassi, Jafari, 2011). For this reason, the role of stores is rising increasingly and stores are also looking for different ways to increase the number of purchases. Comment 2: Store managers should always monitor their interactions with customers and provide them with a clear understanding of their needs and values, as well as the valuable goods and services offered. This approach fosters customer loyalty and satisfaction (Rostami et al, 2019). Upon rising incomes and purchasing power, impulse purchase increases and appears as a dominant consumer behavior. According to the available literature, if customers buy only when needed, market economy fails that is one of the fundamental issues present time (Darvishpour, 2011). In today's competitive market, the most important thing is different tastes of customers that are considered as important issues of organizations. Some purchase centers, by putting a variety of products in their shop window and decorating them, attract customers. So paying attention to importance of hedonistic values, difference (distinction), perceived and sense of attachment (interest) to purchase centers is one of the major requirements for administrators in recent decades (Soleimani, 2012). It was also reported that 90 percent of people do occasional impulse purchases and in some specific products 80% of the total purchase is impulse purchase (Ghaderi, Abed, 2011). Today, each customer has its own special value and purchase centers should fight to gain more share from stable or declining market (Bellinger et al., 2008). Recently researchers in their patterns and models, in order to more realistic study of purchase or consumption experience, consider emotional and hedonistic and materialistic variables too. Given the importance mentioned for perceived value of

purchase, and the important role these values play, this study is to identify the relationship between perceived values of customers (hedonism, materialism), through green image of store with the tendencies of impulse purchase and customer loyalty, because if there is a relationship, the purchase centers under study can increasing their loyalty by considering these components, and achieve advantages such as more sales and earning higher incomes. Thus, this subject is very debatable in field of behavior of Iranian consumers, on the other hand it is trying to complement previous researches and provide some solutions in this field.

Theoretical base and background of research

In today's world, to buy and consume, consume is facing a variety of products that have distinctive features from each other and somehow are able to meet some of the needs of consumers. Since companies are always looking for profit and for profit should consider customer needs and requirements, thus, consumer behavior is raised and it is one of the important topics and branches of marketing. In the field of consumer behavior types of purchases are raised one of which is planned purchase and the other unplanned purchase (Dilafruz, Taleghani, 2010).

Purchase values of customer represent transaction between quality and guarantee received in related to price paid for achieving it (Dadlz et al., 2013). Hedonistic purchase value includes entertainment, excitement and pleasure of purchase experience. Customers who follow hedonistic purchase value seek the joy and fun of it and describe good purchase a coincidence and aimless subject for experience of shopping (Solomon, 2012). Hedonistic purchase value is subjective and individual. This value can be realized through the joy and excitement, rather than achieving the goal (Hirschman, Hulborok, 2012). Materialism is defined as degree of importance people give for their material products and ownership of them. For these people, satisfaction and pleasure of life as well as judgment about progress of one

and others is on the basis of material assets. Earning money is success for them and wealth is at the center of their lives (Irene et al., 2012). Green image is positive feeling that people have with hearing the name of the store. A positive image of a business includes facts, events, history, personal and commercial advertisements that create a belief in the public mind (Kotler & Armstrong, 1988). According to existing research, environmental information positively affects consumer attitudes and increases awareness, and companies use resources to increase consumer views on the innovation and value of green brands and green image of stores in increasing consumer awareness (Sondhi et al., 2023). Consumers' intention to purchase often depends on the company's marketing strategy, the customer's attitude and importance towards the transaction. Consumers' positive feelings and attitudes toward a product/service, or specifically a store, influence their purchase intention. The intention to buy from a retail store is influenced by some external factors such as the brands sold in the store, location and timing and some intrinsic factors such as fulfilling a need, fulfilling a preference and putting the consumer in a better position (Golalizadeh, 2023). Impulse purchase is complex, sudden, involuntary and unnecessary behavior that in this behavior, high speed in decision-making process prevents wisely and tactfully reviews of all information and other options. This behavior, compared with the planned purchase, has more excitement and less precision and avoiding doing it less commonly happens (Mahmud, 2012). Loyalty is one of the strong predictors of customer retention, or in other words, business retention factors between a customer and a service provider or repurchase of a particular brand.(Dehghan et al, 2015). On the other hand, a strategy based on customer loyalty provides many benefits, especially in the conditions of high competition and complex environments.(Tabaku & Kruja, 2019)

Customer loyalty is a type of deep-seated commitment that leads to repurchase or re-

use of a specific product or service is. However, situational effects and marketing proposals potentially affect the change in consumer behavior (Oliver, 2009). On the other hand, greater customer satisfaction leads to increased customer loyalty, reduced service delivery costs, easier customer retention, and greater employee participation (Zadegan et al., 2023). Loyalty happens when customers strongly feel that the considered organization can best possibly

meet their needs, so that competing organizations get out of customers considerations and they purchase exclusively from the considered organization (Lyvas, 2010). A commonly stated definition of brand loyalty is that "it is a consistent consumer preference for buying a brand in particular products or services, and high brand loyalty has a significant impact on sales." (Parayil Iqbal and et al., 2023).

Decision making process of purchaser

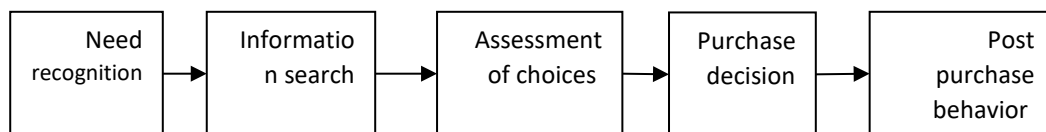

Figure 1. *Decision making process of purchaser (Cutler, 2010)*

The figure above shows that the decision to buy is made up of five stages: Recognizing of need, search for information, evaluating options, purchase decision and post-purchase behavior. It is clear that purchase process starts before real purchase continues much later. Instead of focusing on the purchase decision, marketers should pay attention to whole process. According to this figure, consumer passes all five stages in every purchase, but usually in normal purchases consumers forget some steps or pass them in reverse. A woman who regularly buys toothpaste, has perceived need and by omitting the stages of data collection and evaluation, goes directly to the purchase stage.

Green image of store and the role of green image in attracting customers

Definition of the green image of the store is not easy. The image is a combination of tangible and intangible dimensions and meanings and relationships between attitudes towards store that is given to customers in the long run, (Bart, 2011). In our culture, public spaces are considered insignificant at design time and after implementation we are concerned about why the buildings are not pleasant places to visit and use by people. In designing store, not only physical design of

store environment must be considered, but also all parts, pathways, entrances, parking lots, sidewalks, road facilities, lighting, furniture and public space should be supervised and controlled. Creating an appropriate atmosphere in the purchase is crucial. People want appropriate space and easy accessible to facilities (Lang, 1988). Store's location in appropriate place and building attractive and distinctive entrance for complex, creating a retreat on the sidewalk, creating a path from the corner to the purchase center, construction of convenient parking, creating perspective from different parts to the surrounding streets, connection of public sidewalks and secondary sidewalks, allocation of retreat for parking area of streets, building public social spaces on the site for success in attracting customers are decisive. Public spaces should be designed in such a way to induce the buyer a sense of community, for this purpose in the spaces common visual elements should be used (Wathiq, 2011). On the other hand, many managers motivate and direct their colleagues and subordinates to maintain a suitable environment in which all company members are directed towards the company's goals, as this also manifests itself in the store environment (Krsteska et al, 2023) The better store picture is, more

customers are attracted to it. When we want to describe concept of store image in more detail, we can divide it into two different parts, one is physical properties of products that are sold in stores such as quality, accessibility, price and psychological effects of these properties, the other interior and exterior design of store for example store building, its space, and display screens in it (Newman, colon, 2011). Despite more complex and sensitive relations between the seller and the buyer, a trend must be continued that is economic and the profitable, so besides persistence, organizations need to have great and positive reputation for sale, employees and customers (green image). The image of organization resulting from judgment of customer's loyalty causes a halo effect. (Landystyd, 2008).

According to review of conducted researches and also based on the general principles of ideas offered, the following hypotheses are offered:

The hypotheses

(1) There is a significant relationship between the perceived hedonistic values

through green image of store and impulse purchase.

(2) There is a significant relationship between the perceived materialist values through green image of store and impulse purchase.

(3) There is a significant relationship between the perceived hedonistic values through green image of store and customer loyalty.

(4) There is a significant relationship between the perceived materialist values through green image of store and customer loyalty.

Given the presented variables and hypotheses of study's conceptual model as brought in this page, it should be noted that framework of this model is taken from the issues of purchase values, green image, impulse purchase, and customer loyalty.

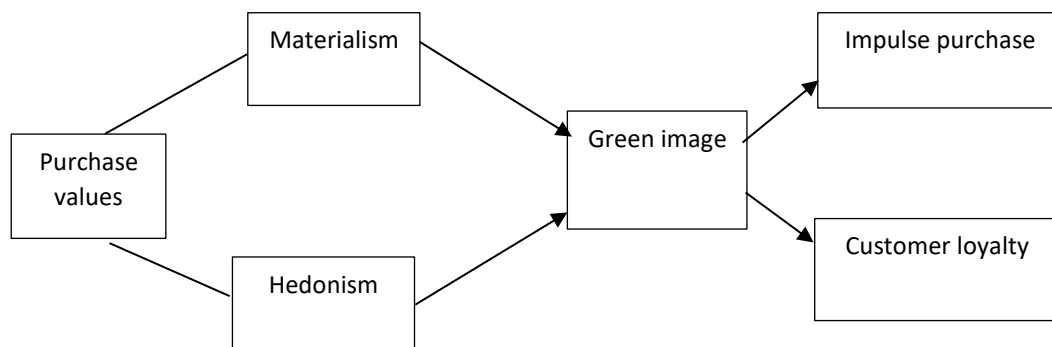

Figure 2. *Conceptual Model*

Source: Mohd, G. & Eren, S. S. & et al. (2012). The effect of green image of retailer on shopping value and loyalty. Eren, S. S. & Eroglu, F. & Hacioglu, G. (2012). Compulsive purchase tendencies Through materialistic and hedonic values among college students in Turkey.

Research Methodology

Regarding nature, this study is applied research, also in terms of data collection and research conduction, it is descriptive survey. This study is correlational in examining the variable; regarding time, it is cross-sectional study and from data collection method respect it is documentary and field research

method and questionnaire is used for data collection; research method is survey and it is Post-event research. In this study impulse purchase and customer loyalty are dependent variables and purchase values (hedonistic values and materialistic values) are independent variables and green image of store is entered in this research as a mediator

variable. In this study, most of setting questions was from a standard questionnaire of Irene et al (2011), but according to some conditions and to localize the questions, researchers made some changes for more ability to perceive the respondents. A questionnaire containing 30 questions was designed in two parts for questions of questionnaire are designed as package and scaled based on the five-item Likert scale for the variables from totally agree to totally disagree. The study sample consisted of all customers are purchase centers in Zanajn city. The statistical sample of this research includes customers from 7 purchase center in zanzan city that the questionnaires is distributed among them and gathered. In this

study to determine the validity of research tool face validity and exploratory tools were used. To investigate the exploratory validity of research questions, factor analysis was used.

To determine the reliability of the study questionnaire, Cronbach's alpha coefficient was used. In this study, spss software version 26 and LISREL software, version 8 were used.

Research Findings

According to the results of the first part of questionnaire (demographic characteristics), the following information are provided about the profile of the sample.

Table 1.

Descriptive statistics

Cumulative percentage	Correct percentage	percentage	percentage	Gender
۴۲/۱	۴۲/۱	۳۴/۹	۱۶۰	male
۱۰۰/۰	۵۷/۹	۴۸/۰	۲۲۰	female
	۱۰۰/۰	۸۲/۰	۳۸۰	total
Cumulative percentage	Correct percentage	percentage	percentage	age
۴/۹	۴/۹	۳/۹	۱۸	20 years and under
۴۱/۱	۳۶/۲	۲۹/۳	۱۳۴	21 to 30 years
۸۲/۷	۴۱/۶	۳۳/۶	۱۵۴	31 to 40 years
۹۷/۳	۱۴/۶	۱۱/۸	۵۴	41 to 50 years
۱۰۰/۰	۲/۷	۲/۲	۱۰	Over 51 years
	۱۰۰/۰	۸۰/۸	۳۷۰	total

Test results off testing research hypotheses are summarized in the table below:

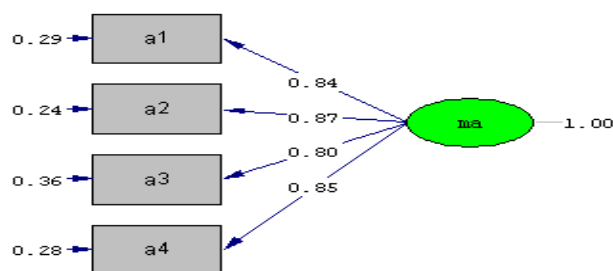

Chi-Square=0.01, df=2, P-value=0.00000, RMSEA=0.000

Model 1. *Materialistic aspect in mode*

In the second model, loyalty is measured using five indicators (items). First, factor analysis was performed on the loyalty variable with five items. Factor load of one of questions (Question 5) was below fifty percent (0.35), so the question was

eliminated and factor analysis was performed again for the remaining four questions. These items include (v4 to v1). Estimations of standardized parameter in Figure 2 shows that all indicators are statistically significant ($p < 0/05$) and their factor loads are at a high

level (greater than 0.5). Study of fitness indicators results also indicate goodness of model fit and all fitness indicators are in

acceptation area. Therefore, measurement of materialism model is accepted without any changes.

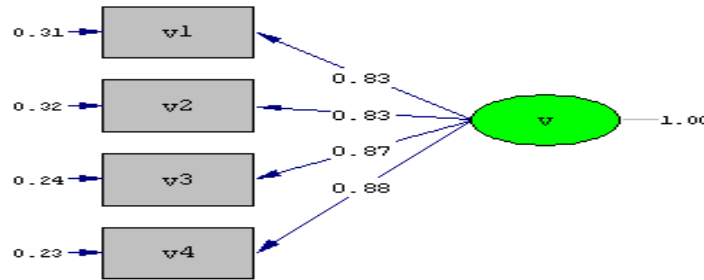

Chi-Square=5.56, df=2, P-value=0.04193, RMSEA=0.068

Model 2. Materialistic aspect in mode

In the third model, hedonism model is measured using five indicators (items). First, factor analysis was performed on variable hedonism with five items. Factor load of one of the questions (Question 5) was below fifty percent (0.42), So the question was eliminated and factor analysis was performed again for the remaining four questions. These items include (L4 to L1). Estimations of

standardized parameter in Figure 3 show that all indicators are statistically significant ($p < 0/05$) and their factor loads are at high level (greater than 0.5). Study of fitness indicators results also indicate goodness of model fit and all fitness indicators are in acceptance area. Therefore, measurement of hedonism model is accepted without any changes.

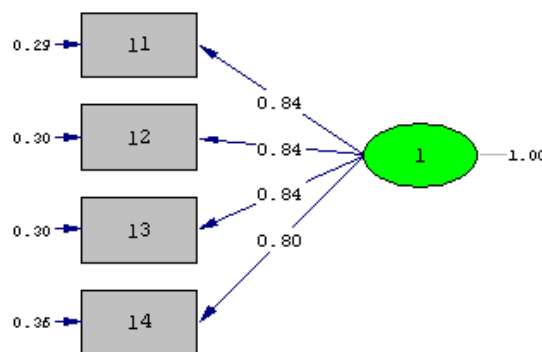

Chi-Square=5.73, df=2, P-value=0.057, RMSEA=0.070

Model 3. Materialistic aspect in mode

In the fourth models, green image is measured using seven indicators (items). First, factor analysis was performed on the variable green image with five items. Factor load of one question (Question 7) was below fifty percent (0.45), so the question was eliminated and factor analysis was performed again for the remaining six questions. These items include (m7 to m1). Estimations of

standardized parameter in Figure 4 shows that all indicators are statistically significant ($p < 0/05$) and their factor loads are at a high level (greater than 0.5). Study of fitness indicators results also indicate goodness of model fit and all fitness indicators are in accepting area. Therefore, measurement of green image model is accepted without any changes.

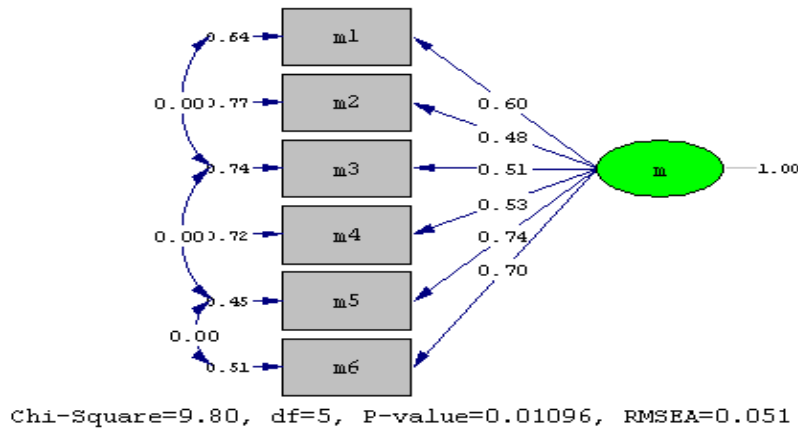

Model 4. *Materialistic aspect in mode*

In the fifth model impulse purchase model is measured using three indicators (items) . These items include (t3 to t1). Estimations of standardized parameter in Figure 5 shows that all indicators are statistically significant ($p < 0/05$) and their factor loads are at a high

level (greater than 0.5). Study of fitness indicators results also indicate goodness of model fit and all fitness indicators except Chi square are in accepting area. Therefore, measurement of impulse purchase model is accepted without any changes.

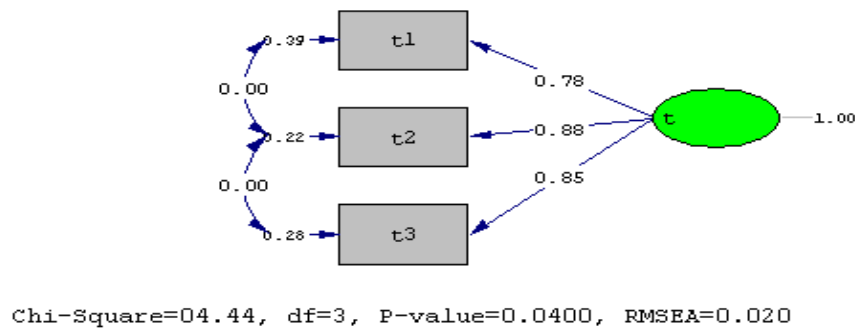

Model 5. *Model of impulse purchase aspect in mode (standard solution)*

Figures 6 and 7 are final model of this study; this model is developed according to the conceptual model and with the support

of theoretical principles. This model is in a state of T-VALUES AND STANDARD SOLUTION.

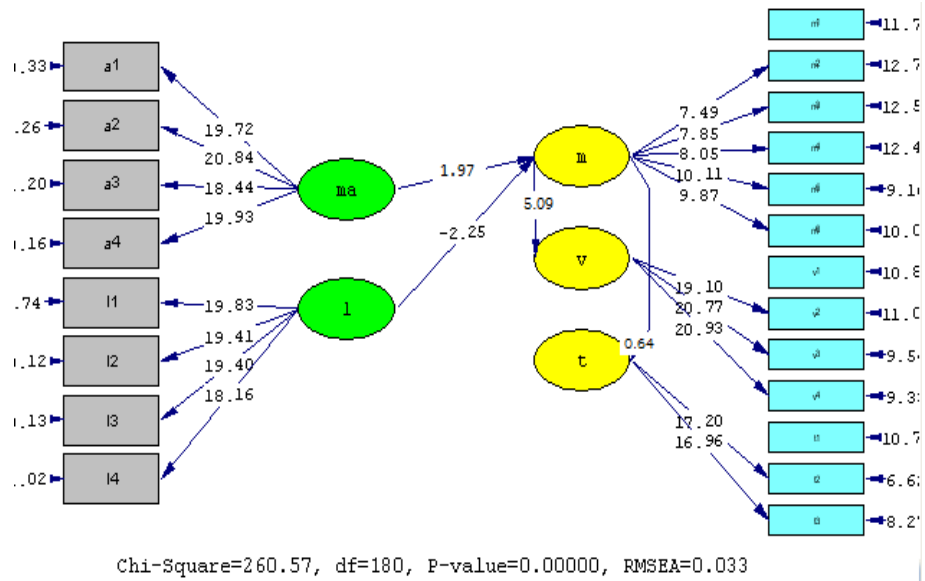

Model 6. Structural equations model of research in mode T-VALUES

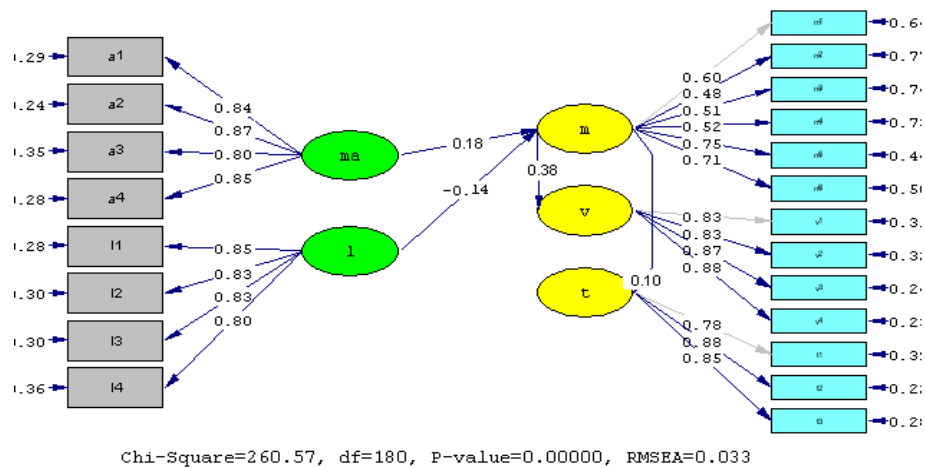

Model 7. Structural equations model of research in mode STANDARD SOLUTION

Table 2 summarizes coefficients of path model of structural equations in this study, in this table values of both models in standard and t mode are brought.

Table 2. Summary of the most important indicators of fitness

T	Standardized coefficient B	Graphical signs	Formative-Reflective path
1/97	0/18	ma	Green image ← — Materialism aspect
-2/26	-0/14	L	Green image ← — Materialism aspect
+0/64	-0/1	m	Impulse purchase ← — Green image aspect
5/09	0/38	m	Loyalty ← — Green image aspect
2/42	0/22	L	Impulse purchase ← — Materialism aspect
-2/54	-0/22	L	Loyalty ← — Materialism aspect
15/40	0/89	ma	Impulse purchase ← — Materialism aspect
17/40	0/87	ma	Loyalty ← — Materialism aspect

Table 3 summarizes the research findings with respect to testing the hypothesis by path analysis. As can be seen, among the four sub-

hypothesis raised by this study, only two hypotheses have been confirmed.

Table 3.

Summary of the findings of research

Hypothesis test results	Type of Relationship	Relationships	Hypotheses
Rejected	Significant	Hedonism - green image	H1
	insignificant	Green image- impulse purchase	
Rejected	Significant	materialism - green image	H2
	insignificant	Green image- impulse purchase	
Confirmed	Significant	Hedonism - green image	H3
	Significant	Green image - loyalty	
Confirmed	Significant	materialism - green image	H4
	Significant	Green image - loyalty	

Model (8) shows the final model of structural equations of research and model (9), the final model of structural equations of

research with regard to the direct influence of independent variables on the dependent variable.

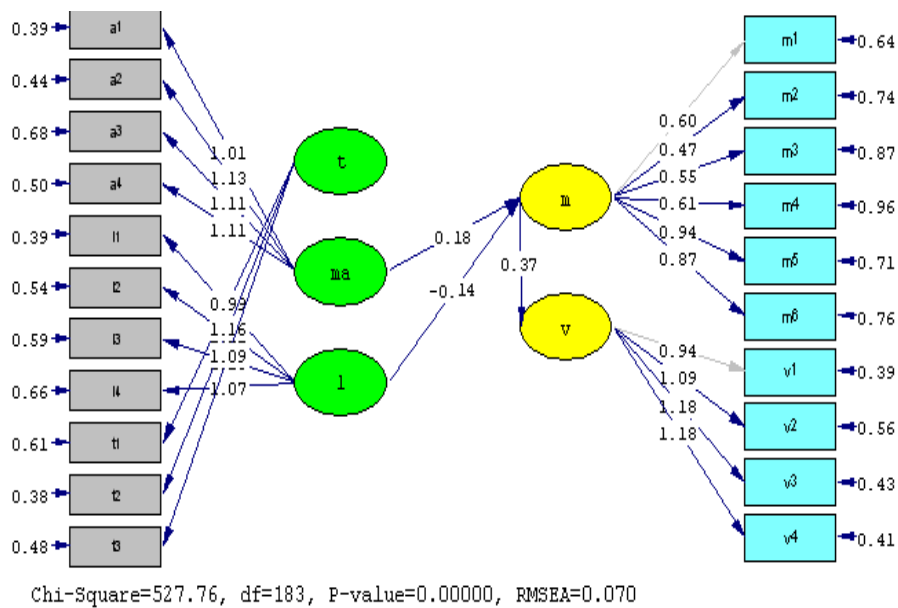

Model 8. *The final structural equation model of research and model*

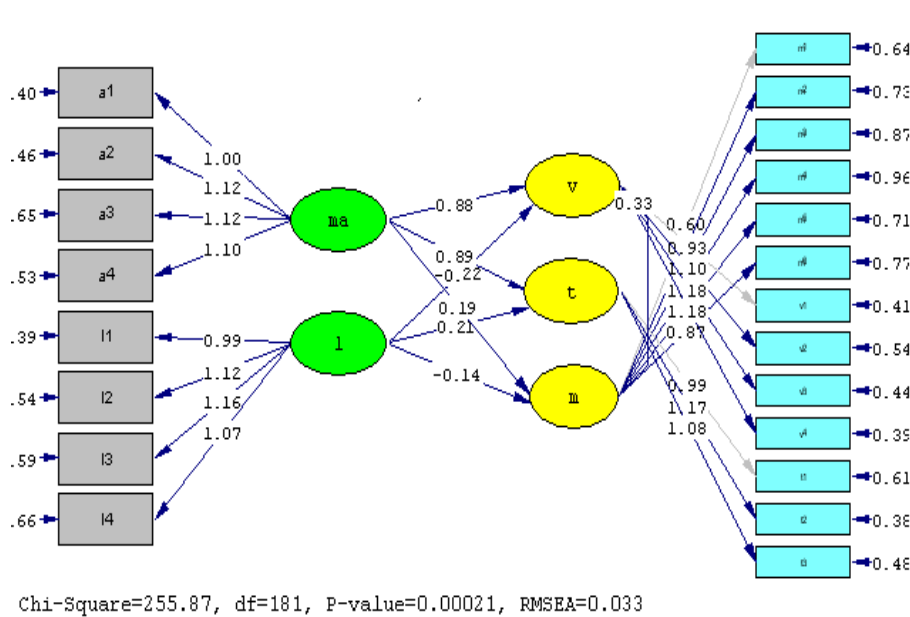

Model 9. *Structural equation model of the study taking into account the direct impact of independent variables on the dependent variable*

Discussion and Conclusion

The aim of this study was to investigate the relationship between purchase values through the green image of store on impulse purchase and customer loyalty. The findings of this study by testing the hypothesis showed that there is no significant positive relationship between of values purchase through green image of store and impulsive purchase. However, there is a significant positive relationship between the values of purchases through green image of store customer loyalty. Given the direct relationship between the values of purchase and impulsive purchases, it can be said that field of marketing positive role store and its feedback on purchase has not been paid much attention.

Since today's customers are not only in search of their intended products and services but want enjoy spending time to this search, so owners are responsible to meet these demands by providing a favorable and attractive environment to increase the number of its loyal customers. On the other hand, all activities should be in harmony with the products and services provided. The more better store image, more customers are attracted to it. on the other hand, according to the relationship between the values of

purchase through the green image of store and customer loyalty, it can be said that today lasting and serving only in one chosen field is not enough. Despite the more complex and more sensitive relations between the seller and the buyer, a trend should be continued that is along with economy and profitability, so besides long lasting organizations need to have positive reputation for sale, employees and customers. Green image in accordance with the rules of limited decision making as an incentive to buy from an organization can act as sign of external information for potential and actual buyers and affect customer loyalty. Today, with increased urban sprawl and shopping malls and promotions in this field, a context is provided so that the values related to the purchase grow and more focus on marketing be created. Since the green image should play a significant role in strengthening values, it is important to note that the store environment significantly affects customer behavior and product evaluation. On the other hand, considering that people in different regions of the world value diverse and unique cultures, it is possible to localize the method presented in this research to cater to the specific needs and

preferences of each region. This opens up new avenues for future research in marketing.

References

- Abbasi, Javad and Jafari, Layla (2011). Investigation of Influential Factors of impulse purchase behavior of women on supermarket products. *Journal of Marketing Management Comment 3*: <https://civilica.com/doc/435293>
- Dehghan, N. A., Alizadeh, H., & Mirzaei-Alamouti, S. (2015). A study on the effects of customer value and perceived value on customer satisfaction, brand loyalty and repurchase intention. *Serbian Journal of Management*, 10(2), 173-188. <http://dx.doi.org/10.5937/sjm10-7844>
- Delafruz, Narges and Taleqani, Mohammad (2010). The effect of personality traits on obsessive purchase and impulse purchase behavior. *Journal of management perspective*. <https://www.academia.edu/4486307/uncaught-error>
- Ebrahimi, E., Irani, H. R., Abbasi, M., & Abedini, A. (2024). The effect of gamification on brand equity and desirable consumer behaviors in online retail stores: The mediating role of brand engagement. *Interdisciplinary Journal of Management Studies (Formerly known as Iranian Journal of Management Studies)*, 17(2), 379-391. <https://doi.org/10.22059/ijms.2023.352786.675544>
- Eren, S. & Eroglu, F. & Hacioglu, G (2012). Compulsive buying tendencies through materialistic and hedonic values among college students in Turkey. 58 pp 1370-1377. <https://doi.org/10.1016/j.sbspro.2012.09.1121>
- Ghaderi, Abed, Amirhossein (2011). Impulse purchase behavior and factors affecting it. *Institute of Humanities and Social Sciences (SID)*. <https://dorl.net/dor/20.1001.1.20085907.1390.3.4.8.3>
- Golalizadeh, F., Ranjbarian, B., & Ansari, A. (2023). An Evaluation and Analysis of Perceived Online Service Quality Dimensions Impacts on Online Purchasing Behavior of Luxury Cosmetic Products by Women. *Interdisciplinary Journal of Management Studies (Formerly known as Iranian Journal of Management Studies)*, 17(1), 37-52. <https://doi.org/10.22059/ijms.2023.337578.674908>
- Heidarzadeh, Kambiz (2011). The Role of utilitarian and hedonistic values on satisfaction of consumers in purchasing clothing in Iran. *Journal of Development and Transformation Management*. year IX , Issue 34, Pages 107-127. <https://www.sid.ir/paper/205845/en>
- Heidarzadeh, Kambiz. and Noruzi, Abdullah (2010). The effect of mental complexity of purchase on recognition of utilitarian products (based on the immediate benefits) and hedonistic products (based on instant gratification), in the consumer's purchase decision making process. *Journal of Management Studies*, Issue 87, Pages 53-40. https://journals.srbiau.ac.ir/article_5109.html
- Howkins, Mothersbaugh and Best, et al, (2010), *Consumer Behavior: Building Marketing Strategy*, 10th edition, McGraw- Hill. https://books.google.com/books/about/Consumer_Behavior.html?id=w0VqPgAACAAJ
- Krsteska, K., Arikan, C. L., Mitrevski, V., & Smilevski, C. (2023). Leadership styles, organizational learning and organizational competitiveness: evidence from the Republic of North Macedonia. *Serbian Journal of Management*, 18(2), 295-314. <https://doi.org/10.5937/sjm18-43019>
- Parayil Iqbal, U., VK, H., & Sainudheen, S. (2023). The Intervening Impact of Social Media Marketing on Brand Loyalty: A Multi Group Analysis in Customer Demographics. *Interdisciplinary Journal of Management Studies (Formerly known as Iranian Journal of Management Studies)*, 16(4), 889-903. <https://doi.org/10.22059/ijms.2022.342872.675097>
- Park. E. J., & Kim, E.Y. (2008). Effects of Consumer Tendencies and Positive Emotion on Impulse Buying Behavior for Apparel. *Journal of the Korean Society of Clothing and Textiles* 32,(6), 980-990. <https://doi.org/10.5850/JKSCT.2014.38.1.87>
- Rook, D.W., & Fisher, R. J (2010). Normative Influences on Impulsive Buying Behavior. *Journal of Consumer Research* 22, 305-313. <https://doi.org/10.1086/209452>
- Soleimani, Hassan (2012). The effect of hedonistic values and utilitarian -based value on overall attitudes customers in shopping centers. *Marketing Management journal*, Issue 15. https://journals.srbiau.ac.ir/article_1640.html
- Sondhi, S., Chawla, U., & Iqbal, H. (2023). Relationship between social cause, environment conservation and environmental attitude, towards promoting green purchasing behavior. *Serbian Journal of Management*,

- 18(1), 27-43. <https://doi.org/10.5937/sjm18-36157>
- Taheri Kia, Friz and Nokhbeh Zaim, Naiim (2012). Some of the factors affecting the tendency to impulse purchase. *Journal of Management of Development and Transformation*, No. 9, pages 66-59.
- <https://sanad.iau.ir/Journal/jdem/Article/949910>
- Tabaku, E., & Kruja, D. (2019). An integrated framework for customer loyalty in the hotel sector. *Serbian Journal of Management*, 14(1), 205-221. <http://dx.doi.org/10.5937/sjm14-18253>