

Design of a tunable optical thin film fabry-perot filter in dense wavelength division multiplexer

Vahideh Khadem Hosseini Ghasemi

Department of Electrical Engineering, High Education College , Islamic Azad University Boushehr Branch ,Boushehr ,Iran

Email: Vahideh_khademhosseini@yahoo.com

Received: December 1, 2012

Revised: December 23, 2012

Accepted: December 28, 2012

ABSTRACT:

We present a design thin film multi-cavity Fabry-Perot filter. These filters are most widely used filtration technologies that made possible technical advancement of modern optical communication system .This paper is concerned with a theoretical study to design and analyze this type of filter. A brief introduction to the thin film multi-cavity filter technology will be presented. The recent progress in design thin film multi-cavity technology will be reviewed. These designs consist of two material Ge/MgF_2 as high / low index. The wavelength range from 300nm to 500nm . The filter is to be coated on Fused Silica having index 1.55 and operates at normal incidence.

KEYWORDS: dense wavelength division multiplex , Fabry-Perot filter, thin film.

1. INTRODUCTION

Thin film multi-cavity narrow band-pass filters are widely used in wavelength division multiplexing (WDM) applications in fiber optic communication systems. These filters must have sharp cut-on and cut-off on either side of the pass band and practically zero transmittance outside the band pass, over the wavelength range of the applications. Wavelength division multiplexing (WDM) is an integral component of fiber optic communication systems and enables several channels of information to be encoded on light signals of different wavelengths and transmitted simultaneously over the same optical fiber, to separated and decoded at the receiving end [1].

The Fabry- Perot multi cavity narrow band-pass interference filter is still the most widely used device for multiplexing and demultiplexing of the different wavelengths transmitted over the optical fiber [2- 4]. The narrow band-pass filters must have very steep cut-on and cut-off transmittance characteristics as

well as very low transmittance at wavelengths other than the transmission wavelength, to avoid crosstalk between the different channels. For Dense WDM (DWDM) applications, the separation between neighboring wavelength channels is less than 1nm and so the width of the pass band of an individual filter must be less than 0.5nm, which makes the fabrication of these ultra-narrowband filters an extremely challenging and difficult task. But for coarse WDM (CWDM) the adjacent wavelength channels are separated by 20nm or more and so the width of a filter band pass can be 12-20nm, making the fabrication of

these filters are more feasible task.

The design techniques for the multilayer stacks used in the fabrication of narrowband filters for WDM applications are described extensively by Thelen [5] and Baumeister [6]. These thin film filters are fabricated by plasma and ion-assisted electron beam evaporation [7], by reactive magnetron sputtering (e.g. the microplasma method [8]) or by plasma impulse chemical vapour deposition [9]. These are several manufacturers of thin film band-pass filter for WDM (CWDM as well as DWDM).

2. THEORY

The basic design of narrow band interferometer. Their basic structure is a multilayer stack of alternately high index and low index thin film, most of which are one-quarter wave thick at the design substrate [10]. The technology of DWDM is one of the most recent and important technique in the development of fiber optic communication technology. In the following section we briefly describe the stag of fiber optic technology and the place of DWDM in the development.

The reality of fiber optic communication had been proven in the nineteenth century, but the technology began to advance rapidly in the late of the twentieth century. After the probably was known that light has an information frequencies. Besides, the additional advantages of fiber optic communication over copper wirability to carry signals over long distances, low error rates, immunity to electrical interference, security, and light weight. Multiplexing and demultiplexing functions both employ narrow band pass filters,

cascaded and combined in other ways to achieve the desired result. Particular techniques that have been used including prisms, diffraction gratings, fiber Bragg Grating, arrayed waveguide gratings (AWG) or thin simple multiplexer or demultiplexer can be done by using a prism demultiplexing case. A parallel beam of polychromatic light impinges on a prism surface; each component wavelength is refracted differently. This is the "rainbow" effect. In the output light, each wavelength is separated from the next by an angle. A lens then focuses each wavelength to the point where it needs to enter a fiber [11].

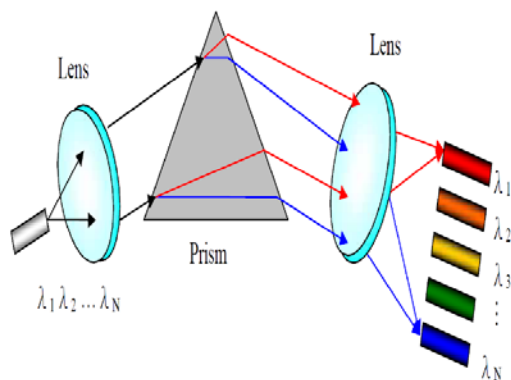

Fig. 1. Prism type of Demultiplexer [12].

Another technology is based on the principles of diffraction and of optical interference. When a polychromatic light source impinges on a diffraction grating (see Figure 2), each wavelength is diffracted at a different angle and therefore to a different point in space. Using a lens, these wavelengths can be focused onto Individual fibers.

A different technology uses interference filters in devices called thin interference filters. Thin-film filters consist of a number of alternate layers of transparent dielectric mate of high and low refractive indices deposited sequentially on an optical substrate. The stack of thin films can be made using one of the coating technologies, such as plasma deposition, and ion assisted deposit long stability, and small losses of chromatic dispersion and polarization system, a thin-film filter would only transmit the wavelength of the optical channel the filter and would reflect all others in the DWDM signal. Figure (3) shows a thin demultiplexer in diagrammatic form. The detail properties will be described in the follow chapters.

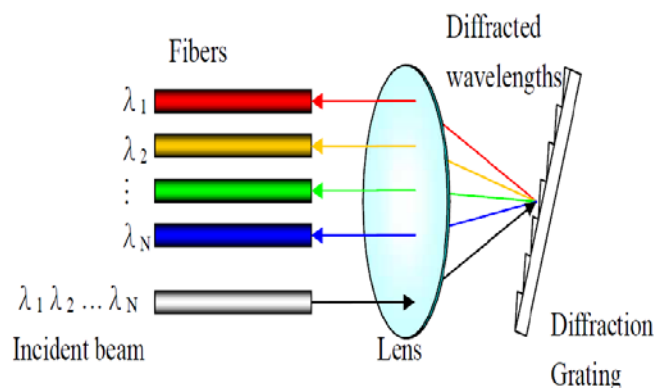

Fig.2. Diffraction Grating type of Demultiplexer [12].

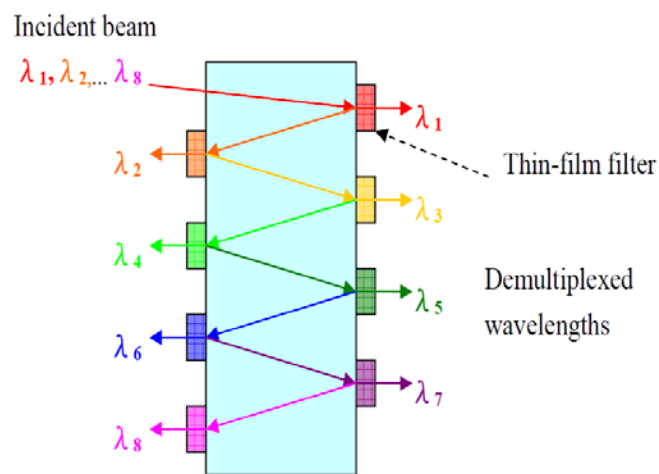

Fig. 3. Thin-film filter type of Demultiplexer [12].

Of these designs, the AWG and thin-film filters are gaining prominence. Their big advantage is that they can be designed to perform multiplexing and demultiplexing operations simultaneously. AWGs are polarization-dependent, and they exhibit a flat spectral response and low insertion loss. Thin-film filters exhibit a very low temperature coefficient, long stability, good isolation between channels, and small losses of chromatic dispersion and polarization-related dispersion. Besides, the cost of a multiplexer/demultiplexers based on the thin-film filters technology is much cheaper than the AWG technology [13]. Please use automatic hyphenation and check your spelling. Additionally, be sure your sentences are complete and that there is continuity within your paragraphs. Check the numbering of your graphics and make sure that all appropriate references are included.

3. STRUCTURE THIN FILM FABRY-PEROT FILTER

The structure of Fabry-Perot Filter is shown in Figure(4). It consists of a spacer layer and two symmetrical reflectors. The spacer layer is a half-wave layer, and the two symmetrical reflectors are composed of alternate quarter-wave layer.

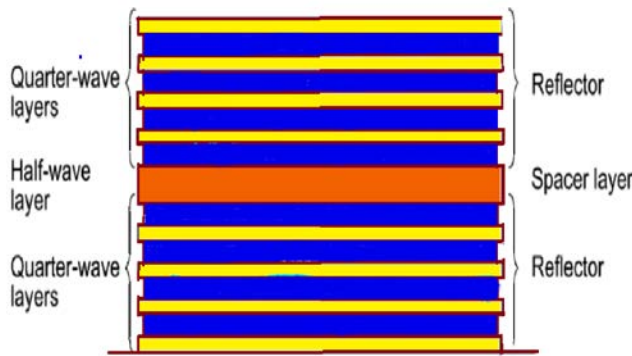

Fig. 4. The structure of Fabry-Perot Filter.

The detailed structure of Fabry-Perot Filter can be divided into two types, of which the membrane structures are (HL) H-2L-H(LH) and (HL) -2H-(LH) respectively, as indicated in Figure(2). “H” represents high-index dielectric medium with optical thickness of quarter-wave, and “L” represents low-index dielectric medium with optical thickness of quarter-wave. From Figure(5), we can see that the “H” layer and “L” layer are alternate anywhere except the spacer layer, in which the medium consists of either two “H” layers or two “L” layers [14].

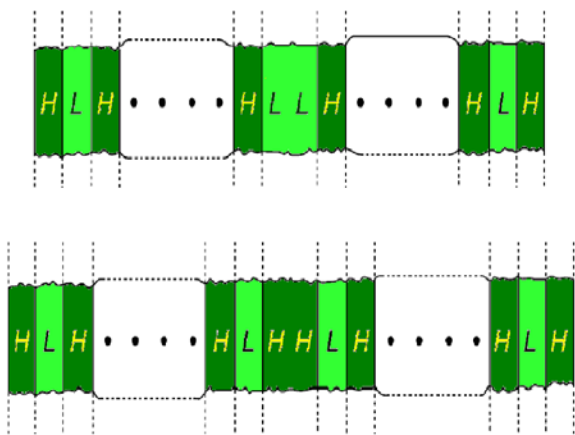

Fig. 5. Two basic types of Fabry-Perot Filter.

As a solid etalon, FPF has an excellent optical filtering Performance . It has a higher finesse than air-spaced etalon. Therefore,-it-is-widely-used in many application systems.

4. RELATED METHOD AND THEORY

We used transfer matrix method (TMM) in this article. Consider the multiple-layer structure shown in Figure (6). There are p-1 layers in between two semi-infinite layers with refractive indices of n_0 and n_s , therefore p interfaces in total. Each layer has a thickness d_j and a refractive index n_j . Each layer j has a characteristic matrix defined by

$$M_j = \begin{bmatrix} \cos \delta_j & i \sin \delta_j / Y_j \\ i Y_j \sin \delta_j & \cos \delta_j \end{bmatrix} \quad (1)$$

Where δ_j is the phase delay of light propagation through the jth layer and is given by

$$\delta_j = 2\pi n_j d_j \cos \theta_j / \lambda \quad (2)$$

Where θ_j is the incident angle in the jth layer, and Y_j is the optical admittance of the jth layer, which is given by

$$Y_j = \sqrt{\frac{\xi_0}{\mu_0}} n_j \cos \theta_j \quad (3)$$

for transverse electric polarization

$$Y_j = \sqrt{\frac{\xi_0}{\mu_0}} n_j / \cos \theta_j \quad (4)$$

for transverse magnetic polarization ,and ξ_0 and μ_0 are the permittivity and permeability of free space, respectively.

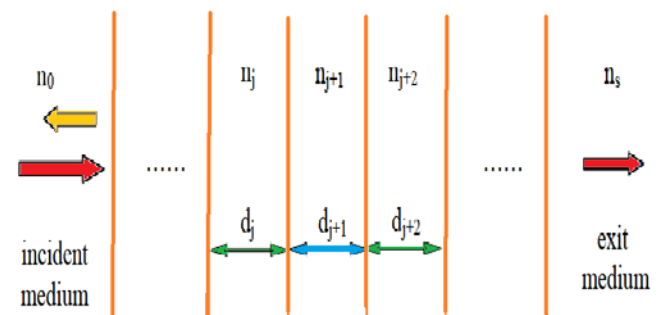

Fig 6. Schematic of a multilayer structure for the transfer matrix method.

There are p+1 layers in total including the incident and exit medium. n_j is the refractive index of the jth layer, and d_j is the physical thickness of the jth layer.

The electric and magnetic fields at boundaries (j-1)/j and j/(j+1) have the relationship given by

$$\begin{bmatrix} E_{j-1/j} \\ H_{j-1/j} \end{bmatrix} = M_j \begin{bmatrix} E_{j/j+1} \\ H_{j/j+1} \end{bmatrix} \quad (5)$$

Then the whole series can be expressed by one characteristic matrix M that is the product of all the layer characteristic matrices.

$$M = \prod_{j=1}^P M_j = \begin{bmatrix} m_{11} & m_{12} \\ m_{21} & m_{22} \end{bmatrix} \quad (6)$$

The reflection coefficient, r, and transmission coefficient, t, can then be expressed as

$$r = \frac{Y_0 m_{11} + Y_0 Y_s m_{12} - m_{21} - Y_s m_{22}}{Y_0 m_{11} + Y_0 Y_s m_{12} + m_{21} + Y_s m_{22}} \quad (7)$$

$$t = \frac{2Y_0}{Y_0 m_{11} + Y_0 Y_s m_{12} + m_{21} + Y_s m_{22}} \quad (8)$$

Where Y_0 and Y_s are the optical admittances of the incident and exit media, respectively.

Thus the reflectance, R, and transmittance, T, are calculated by $R = rr^*$ and $T = tt^*$ / .[15]

5. THE CHOICE OF MATERIALS

The development of optical filters for different wavelengths is important for many communication instruments. Currently available filters are based on interference in multilayer stacks (so-called multilayer interference filters).

The material layer is required mainly for multilayer system have high transmittance in [16]. Taking into account that thin films in multilayer interference coatings must be dense and have low absorption in the wavelength range defined for the intended application [17].

The arrangement of material on two faces of substrate must be according to the value of refractive index. First material have higher refractive index than second material as consequently the light will be suffer many of refraction as Snell's law to obtain the desired wavelength as shown in figure (7) and (8).

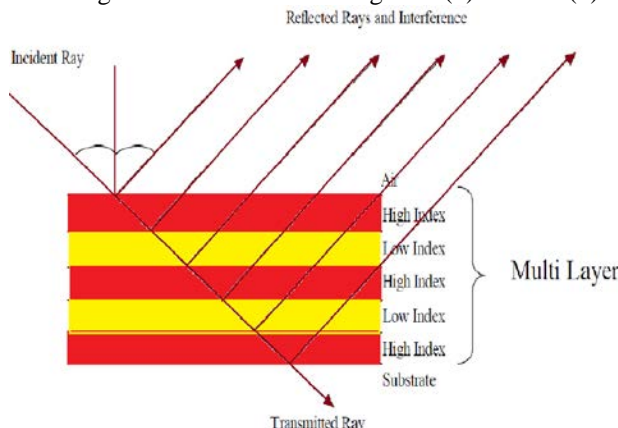

Fig.7. Reflection, Transmission and layers arrangement

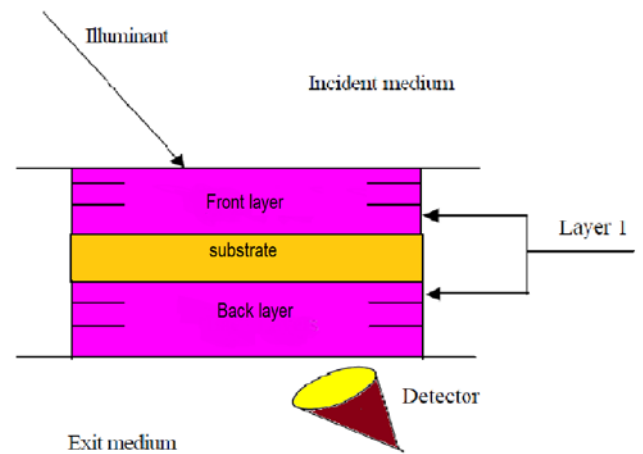

Fig. 8. Arrangement of material on two faces of substrate

When the difference in optical path length between the rays transmitted at successive reflections is such that the emerging waves are in the same phase, constructive interference will occur and filter will show the maximum transmittance value.

If this condition does not hold, the interference between successive emerging rays will be destructive and the transmission will be relatively low [18].

This filter design consist of two material. Ge is high index layer and MgF is low index layer. The wavelength range from 300nm to 500nm. The filter is to be coated on Fused Silica having index 1.55 and operates at normal incidence

6. RESULTS AND DISCUSSION

In the present work, these theoretical designs have been suggested and their profiles have been fully studied for the visible region and near IR region using open filter software [14]. The technology of DWDM is one of the most recent and important technique in the development of fiber optic communication technology.

The band-pass filter used for detecting light at range wavelength 300nm-500nm as in design below out of these wavelengths the filter is allowed to transmit nearly zero as in figure (9). The filter is to be coated on Fused Silica having index 1.55. The filter operates at normal incidence. The most common structure for narrow band-pass filters (multi-cavity band-pass filters) is an all-dielectric filter consisting of a quarter-wave optical thick layers for the mirrors and half-wave optical thick, or multiple half-wave optical thick layers for the spacers. So that the open filter

program can be used to design this filter, we use Ge and MgF as the tow coating materials. The layers structures of narrow band pass filter for tow designs

can be seen below. The characteristics transmission vs. wavelength clearly seen from figure (9) which shows the center to center spacing of the channels in wavelength units.

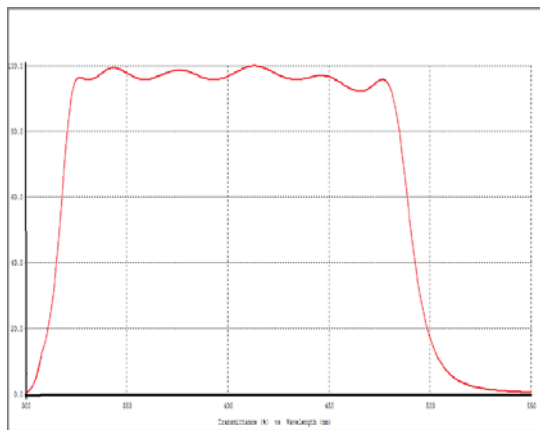

Fig. 9. Transmission vs wavelength for Fabry-Perot Filter

Conclusion

This type of band-pass coating is used in telecommunications industry to control the transmission of multiple laser lines (i.e., channels) through fiber optic cables. The spacing between laser wavelengths is denser, allowing the fiber to transmit more information. A popular component for adding a channel (multiplexing) or removing it (demultiplexing), is a thin-film narrowband filter that transmits one channel and reflects all others. The production of such filters in sufficient volume is the most demanding task ever undertaken by the optical thin-film industry.

There are many other applications of multi-cavity filters such as spectral radiometry, medical diagnostics, chemical analysis, colorimetry, environmental monitoring, security systems, avionics, space-based laser communication systems, space and ground base telescopes, and others.

REFERENCES

- [1] A Baus, KMK Srivatsa, T K Chakraborty & T K Bhattacharya, "Fabrication of narrow bandpass filter for wavelength division multiplexing applications- A feasibility study", Indian Journal of Engineering & Materials Sciences, Vol.14, April (2007), pp.125-132.
- [2] Baumeister P W, "Laser Focus World", July (2001) 145-146
- [3] Morton D. Soc vacuum coating Technology, conf.proc, (2003) 1-6
- [4] Baumeister P W, "Optical Coating Technology", 1st (SPIE press, Washington), (2004), ch1 and ch7.
- [5] Thelen A, "Design of optical interference coatings" 1st ED (McGraw Hill Book Company, New York), ch10 (1989).
- [6] Baumeister P W, App opt, 42 (2003) 2407- 2414.
- [7] Zoller A, Gotzmann R, Mats K & Cuhing D, App. Opt., 35 (1996) 5609-5612.
- [8] Scobey MA, Spock DE, Grasis ME & Beattie JA, proc opt Fiber comm conf.(USA), (1996), 242- 243
- [9] Bauer S, Klipper L, Rothaan U, & Kuhr, "Thin solid films" 442, 189-193(2003).
- [10] Macleod H A, "Thin film optical filter" 2nd Ed (Adam Hilger Ltd, Bristol), ch7(1989)
- [11] J. Minowa and Y. Fuji, "Subnanometer bandwidth interference filter for optical filter communication system," Appl.Opt. Vol. 27, pp. 1385-1396, (1988).
- [12] Chanies thesis "Research of Dependence of the Uniformity on the design and Fabrication of Sub-Nanometer Narrow band-pass Filters" 91246004pdf (1995).
- [13] R. R. Willey, "Achieving narrow bandpass filters which meet the requirements for DWDM," Thin Solid Films Vol.398, pp. 1-9, (2001).
- [14] H A Macleod, Thin-Film Optical Filters. London, U.K.: Institute of Physics Publishing, (1999)
- [15] Yeh, Pochi, "Optical Waves in Layered Media", 1. Edition, 2005
- [16] Marc Christophersen, Vladimir Kochergin and Philip R. Swinehart, "Porous silicon filters for mid-to-far IR range", Proc. of SPIE Vol. 5524, 2004.
- [17] Xuanjie Liu, Xun Cai, Jinshuo Qiao, Jifang Mao and Ning Jiang, "The design of ZnS/Ag/ZnS transparent conductive multilayer films", Thin Solid Films 441, p(200-206), 2003.
- [18] G. Pérez, A.M. Bernal-Oliva, E. Márquez, J.M. González-Leal, C. Morant, I. Genova, J.F. Trigo and J.M. Sanz, "Optical and structural characterization of single and multilayer germanium/silicon monoxide systems", Thin Solid Films 485, p(274 - 283), 2005