



JMRA

Journal of Mechanical Research and Application

ISSN: 2251-7383, eISSN: 2251-7391



Power losses due to dirty solar panels , Cleaning Mechanism of Solar Photovoltaic Panel : A review

Saeed Samadzadeh Baghbani ¹

¹ PhD student Of Mechanics , Islamic Azad University, South Tehran Branch , Tehran , Iran

Samadzadeh65@gmail.com

Received: 2021-05-17

Accepted: 2021-05-12

Abstract: If dust settles on solar panels, it greatly reduces solar energy efficiency and is economically detrimental.; For this reason, the viability of photovoltaic power in smart grids is threatened. The power supplied by a photovoltaic module depends greatly on the amount of irradiance reaching the solar cells.. There are a number of factors that determine the optimal performance of a PV module. But the environment is one of the parameters that directly influences photovoltaic performance. In this article, we examine the factors that reduce the efficiency of solar panels. We also describe various solutions for removing dust sitting on photovoltaic panels to the output power of the panel to reach the highest level. The electrical properties of photovoltaic (voltage and current) in relation to the shadow caused by dirt are discussed.. Pollution on panels is divided into two categories, light shadows such as air pollution and hard shadows that occur when a solid such as dust prevents sunlight from reaching part of the panel.. Increasing dust on the surface of solar panels reduces the amount of sunlight reaching the photovoltaic panel cells.therefore, the efficiency of the solar panel is severely impaired. To maximize their ability, they must be cleaned periodically, usually with water. Due to the lack of water in some areas, cleaning is difficult, challenging, and consequently expensive. Of course, water desalination devices can also be used to provide the water needed to clean solar panels. Solar photovoltaic technology can have a significant impact on the industry, agriculture, and domestic consumption in reducing fossil fuel consumption and reducing environmental and air pollution.

Keywords: Photovoltaic (PV), Dust intensity , Power loss , Solar Cell

1. Introduction

In this era of rapid technological progress, traditional energy sources are being replaced by renewable energy resources for various economic and environmental reasons. Solar energy is one of the most common forms of renewable energy.This energy is utilized by solar photovoltaic cells. Solar energy is also one of the cleanest and most accessible sources of renewable energy. It is noteworthy that it is highly dependent on local climatic conditions, which can significantly alter the efficiency of a solar panel due to various processes, such as soil losses. Large quantities of soil accumulate at the surface of a photovoltaic solar panel in this process. Dust

accumulation is the norm in areas where there are large amounts of soil, dust or sand storms, like in the Middle East, this site-unique phenomenon can motivate an electricity technology loss exceeding one percentage in keeping with day Dust from agricultural emissions and enterprise emissions in addition to engine exhaust, pollen, plant debris, fungi, mosses, algae, micro organism biofilms, fowl droppings, and mineral dirt deposits are a number of different types of localized infections that could decrease and disperse sunlight, thus affecting the overall performance of solar photovoltaic cells.. [1]Dust accumulation at the surfaces of PV panels results in a discount withinside the energy produced through sun energy structures Without a appropriate mitigation method to deal with those soiling losses, specifically in wasteland countries, the financial losses amassed over numerous weeks may be a substantial hurdle to the viability of the usage of sun energy as a cost-green and sustainable electricity useful resource that may be meshed reliably in any hybrid electricity matrix. Moreover, the cleansing prices required to lessen dirt deposition on sun panels may be economically challenging [2,3]

2. Lost current due to dirt on the solar panel.

The output power of a photovoltaic module depends heavily on how much irradiance reaches the solar cells. Numerous factors determine the optimum efficiency of a PV module. But the environment is one of the parameters that directly influences photovoltaic performance. The end result indicates that smooth shading influences the modern supplied through the PV module, however, the voltage stays the same. In difficult shading, the overall performance of the PV module relies upon whether or not a few cells are shaded or all cells of the PV module are shaded. If a few cells are shaded, then so long as the unshaded cells get hold of solar irradiance, there can be a few outputs even though there can be a lower withinside the voltage output of the PV module. This examination additionally offers some cleansing techniques to save you dirt accumulation on the floor of sun arrays. Solar power, which comes from the solar withinside the shape of solar irradiance, maybe at once be transformed to strength via way of means of the usage of photovoltaic (PV) generation. PV generation makes use of solar cells made from semiconductors to take in the irradiance from the solar and convert it to electric power. Currently, solar power has drawn global interest and is gambling a critical function in offering smooth and sustainable power [4] However, their seek associated with the character of semiconductors, which can be utilized in solar cells, has restricted the performance of PV systems to 15–20%. Thus, as a way to grow the performance of the PV machine, a few enhancements along with making use of solar trackers and most strength factor monitoring controllers were made to the PV machine installation. Solar panels are typically expected to be designed to produce optimal performance. Factors that influence the determination of ideal production or optimal yield can be classified into two categories: modifiable and non-modifiable variables.. The variables that may be modified offer layout flexibility to fulfill numerous setup requirements, even as the variables that can not be modified want to be followed with the aid of using default.. The diverse changeable and unchangeable variables impact the configuration and layout of a solar panel, the installation, and operation of a solar panel, and play a critical component in sun panel generation. However, as increasingly PV electricity plant life are constructed withinside the top MW and GW electricity tiers withinside the future, there's a want for extra interest to be paid to this tricky area, which at once impacts the performance of the electricity generation. The features of a PV module can be demonstrated by curves of supply voltage or current voltage. Fig. 1 shows the power– voltage curve of a PV module for different conditions of solar irradiance and cell temperature. PV module characteristics can be shown using supply voltage or current voltage curves. Low irradiation leads to low power, and high temperature leads to a decrease in output power. In addition, each curve of the PV module has a point on the curve where the PV module provides maximum power to the load. This point is known as the maximum power point [5]. Sunlight and cell temperature are two factors that affect the performance of a PV module. In addition to these factors, the amount of energy

supplied by a PV module depends on other factors such as the reliability of other components throughout the system and other environmental conditions. These factors are described below. [6,7].

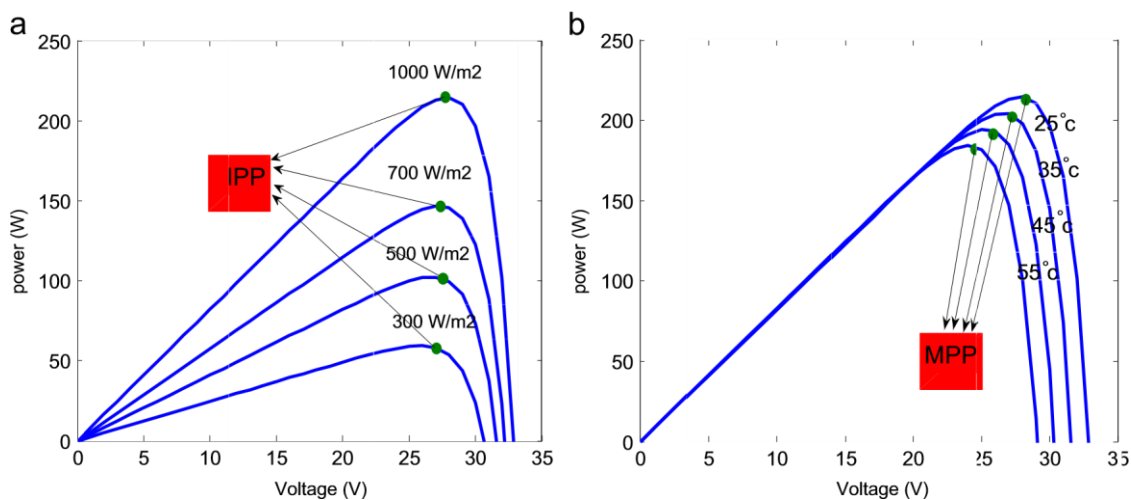

Fig. 1. P–V characteristics of a PV and location of the maximum power point for different irradiances at 25 °C, (b) different temperatures at an irradiance of 1000 W/m².M.R [1]

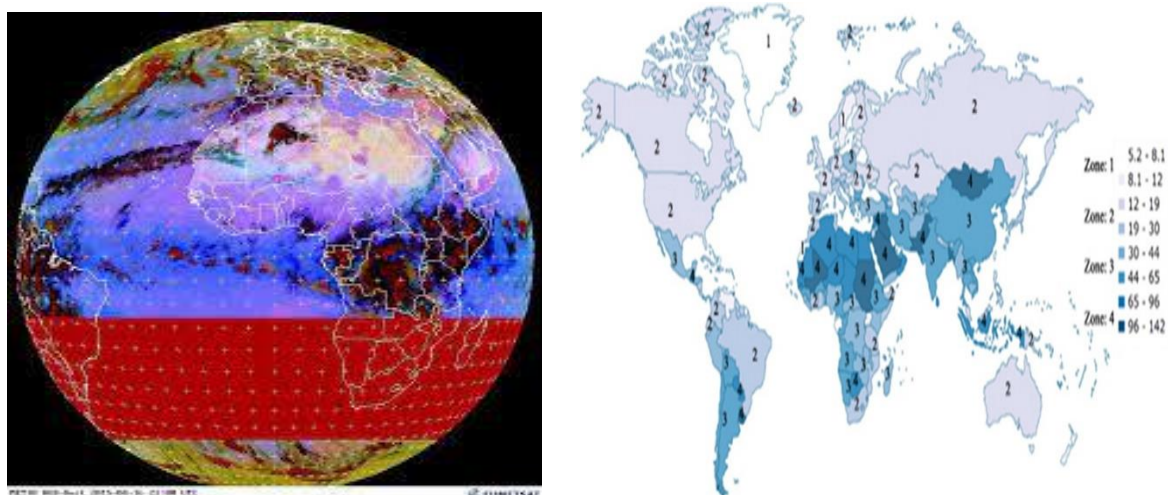

Fig2. Global dust intensity.

The PV system is disrupted by a lack of non-linearity between current and voltage in a partially shaded state.(OSC). Based on statistical studies the power loss can range from 10% to 70% due to PS. [8].

3. Critical survey in the dust

Many studies have been carried out on photovoltaic performance. Although the efficiency of PV systems has been improved by many improvements, environmental and natural factors such as soil, salt, bird droppings, snow deposits on the surface of PV modules do not allow such systems to perform well. It will be efficient. In order to ensure maximum efficiency and energy efficiency, a thorough analysis of the effect of dust on solar panels is necessary. In addition to analyzing the implications of such issues, this article reviews previous research in this area to identify notable information. A three-month trial was carried out by Hottel and Woertz [9] at an industrial site near a four-rail rail 90m from Boston, Massachusetts to study the effects of dust accumulation on solar panels. According to their findings, the average loss of 1% of incident solar radiation is caused by dust accumulating

on the surface of the solar panel with a 30° inclination angle. During this period, the highest recession found was 4.7%. This led the researchers to determine the correction factor as the transmission ratio of a dirty sheet of glass or in contact with a clean glass, 0.99, with an angle of inclination of 45°. Surprisingly, this value was recognized in the design of ordinary flat collections until 1970.

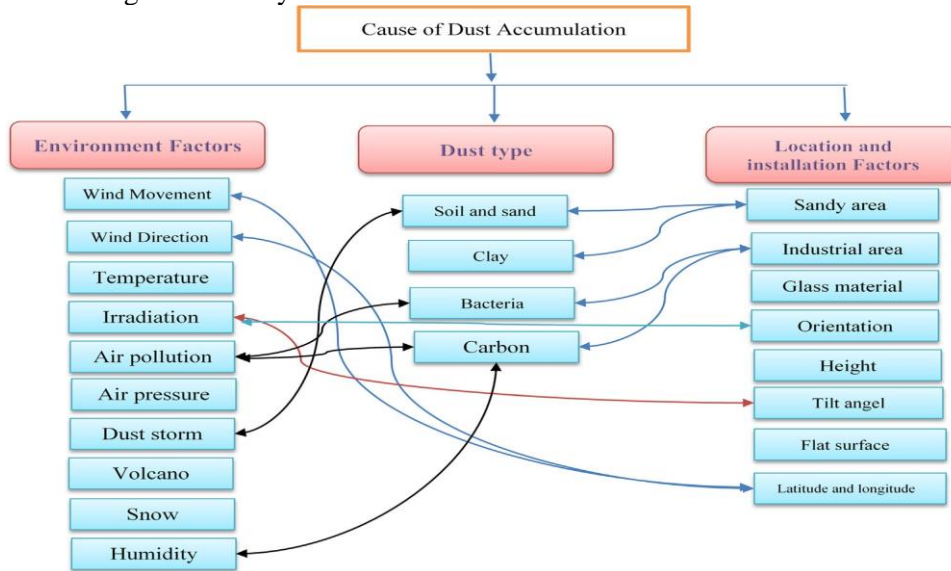

Fig. 3. Cause of dust accumulating on the surface of solar arrays.

4. Why Dust Accumulates

There are two interdependent parameters that affect the pollution accumulation characteristics of solar panels, the characteristics of the dust, and the local environment. Dust properties consist of size, composition, shape, and weight. [10]. For instance in Malaysia, dust in the acid and may cause erosion to the surface of the panel. Local environment refers to an environment created directly or indirectly by human activities such as the built environment, types of vegetation, and weather conditions. Also, the surface is a very important contamination factor. If the surface is rough, bright, and sticky instead of uneven, it tends to accumulate more dirt. The position of the panels, which depends on the direction of sunlight and wind, is also important in the contamination process. The more horizontal the surface, the more dust can accumulate. Also, light wind can cause dust accumulation, and strong wind can clean the panel surface. However, wind-induced airflow can affect dust accumulation or dispersion in certain areas of a solar panel. [11]. The speed and pressure of flight on the surface of a solar panel are not constant. In high-speed winds, the pressure is lowered, resulting in less soil accumulation and vice versa. Dust properties such as type, size, weight and shape also play an important role in dispersion. in the picture. 3 shows the various problems leading to soil accumulation in solar panels. It also shows that some factors have correlations that indicate errors that should be investigated in future studies.

5. The impact of soft shading and hard shading on the performance module

In general, there are two types of soil shading for PV modules. Hard awnings and soft awnings. Severe shading occurs when solids, such as accumulated dust, block sunlight in a clear, identifiable form. On the other hand, soft shading occurs when some particles, such as atmospheric smog or dust on the PV module surface, reduce the overall intensity of solar radiation absorbed by the solar cell. Each of these types of shading has a different effect on PV modules. Soft shading affects the PV module current, but the voltage remains the same. In the case of hard shading, the performance of a PV module depends on whether some or all cells of the PV module are shaded. If some cells are shaded, current will flow as long as the unshaded cells receive some solar radiation. As mentioned

earlier, this condition can cause a partial shadowing hotspot condition, but a bypass diode can be used to solve the problem. For hard shading, all cells in the PV module are dimmed and the PV module is not transmitting power. FIG. Figure 4 shows how each type of shading affects the voltage and current of the PV module, and Figure 4 shows the current-voltage characteristics of the solar module for each shading state in Figure 5. As can be seen from the figure, in the case of soft shading, the voltage of the PV module remains constant and the lower the light absorbed by the solar cell, the lower the current of the PV module. On the other hand, hard dimming of some PV module cells will drop the PV module voltage, but the current will remain constant because the unshaded cells still receive solar radiation.

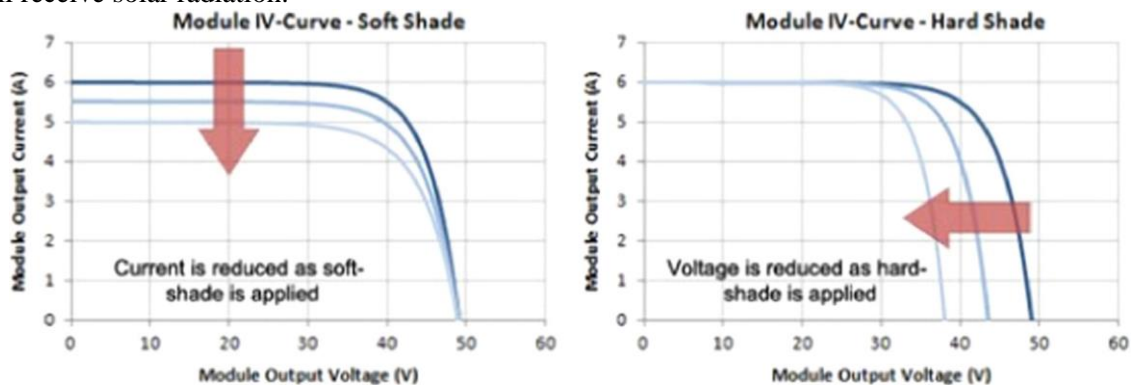

Fig. 4. Voltage–current characteristics of a PV module for soft and hard shading.

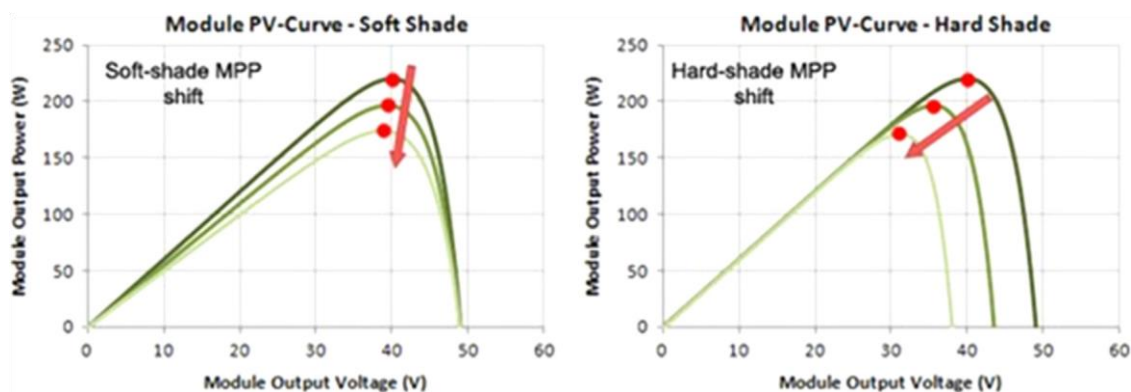

Fig. 5. Voltage–power characteristics of a PV module for soft and hard shading.

6. Photovoltaic technology

Solar power is a field of technology and research related to devices that directly convert sunlight into electricity. Solar cells are the basic building blocks of solar technology. Solar cells are made of semiconductor materials such as silicon. One of the most useful properties of semiconductors is that they can easily change their conductivity by adding impurities to the crystal lattice. For example, when manufacturing solar cells, silicon with four valence electrons is processed to increase its conductivity. On one side of the cell, an impurity, a phosphorus atom with five valence electrons, provides loosely bound valence electrons to the silicon material, creating an excess of negative charge carriers. A boron atom (p-donor) with three valence electrons, on the other hand, creates a greater affinity than silicon for attracting electrons. Since p-type silicon is in close contact with n-type silicon, a pn junction is formed, and electron diffusion occurs from a region with a high electron concentration (n-type side) to a region with a low electron concentration (p-type side). When electrons diffuse through the pn junction, they recombine with holes on the p-type side. However, carrier diffusion does not occur indefinitely because the direct charge imbalance on both sides of the junction creates an electric field. This electric field forms a diode that allows

current to flow in only one direction. Ohmic metal-semiconductor contacts are installed on both n-type and p-type solar cells, and the electrodes are ready to be connected to an external load. When a photon of light strikes a cell, it transfers energy to charge carriers. The electric field at the junction separates the photogenerated positive charge carriers (holes) from their negative counterparts (electrons). So current is drawn when the circuit is closed from an external load. There are several types of solar panels. However, more than 90% of solar cells produced worldwide today consist of wafer-based silicon cells. They are cut from single-crystal rods or blocks of many crystals, so they are called monocrystalline or polycrystalline silicon solar cells. Wafer-based silicon solar cells are about 200 microns thick. Another important family of solar cells is based on thin films about 12 microns thick, requiring much less active semiconductor materials. Thin-film solar cells can be produced at a lower cost in mass production. Therefore, their market share is likely to increase in the future. However, since they are less efficient than wafer-based silicon solar cells, more exposed surfaces and mounting materials are required for similar performance.

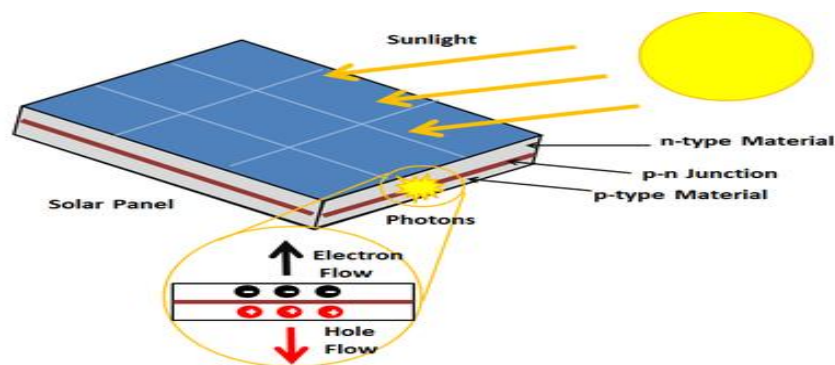

Fig 6 . Solar Cell

A series of electrically connected solar cells mounted on a single support structure or frame is called a "photovoltaic module". Modules are designed to supply electricity at a specific voltage to, for example, an existing 12 volt system. The current generated is directly related to the intensity of the light entering the module.. Multiple modules can be connected together to form an array. Photovoltaic modules and arrays generate DC electricity. They can be connected in series or parallel to achieve the required voltage and current combination.. There are two main types of PV systems. The grid-connected system is connected to the grid and supplies power to the grid. For this reason, the direct current generated by solar modules is converted into grid-compatible alternating current.. However, solar power plants can also operate without a network, which is called a stand-alone system. Currently, over 90% of the world's solar systems are implemented as grid-connected systems. The air conditioning unit also monitors the operation of the system and network and shuts down the system in case of malfunction. [12]

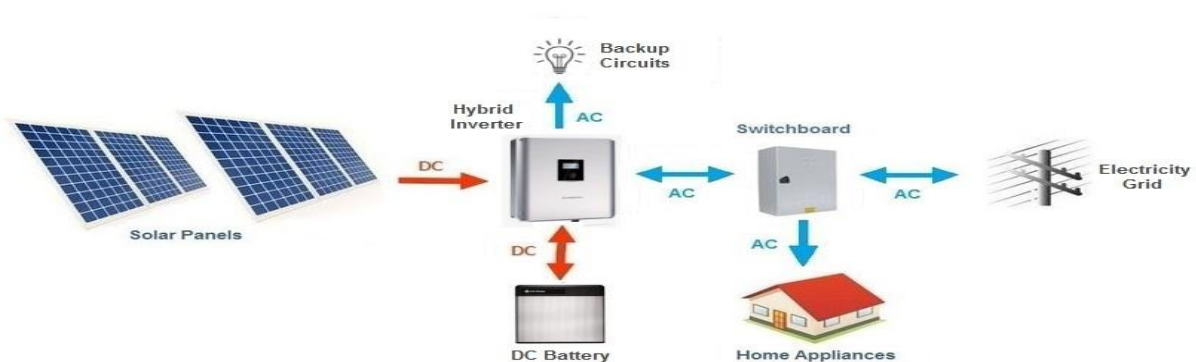

Fig 7 . Pv

7. Solar photovoltaic panel cleaning device

In terms of cleaning performance, it is important to note that rain is often not enough due to some types of dust, cement, and adhesion. The same applies to unwashed poultry droppings. However, cleaning solar panels is not always easy. First, it is an accessibility issue. Because PV panels are often located in hazardous and hard-to-reach places, they are difficult to clean by hand and can take time to clean safely. However, leaving panels uncleaned can also be impractical, as contamination can cause irreversible damage to the glass, limiting the service life of the device. A logical solution would be to automatically clean up automatically. The electrical parameters of solar panels are sensitive to dust density, so it is very important to provide an automatic cleaning mechanism that removes dust particles from the panel surface to ensure high performance.

8. Automated solar panel systems

A Boston University study reported the costs and benefits of three modern solar panel cleaning methods. These methods include natural cleaning by rain and snow, manual cleaning and cleaning by the electrodynamic system 'EMF'. A new technology called EDS consists of interdigital (indium oxide) electrodes on a transparent dielectric film. The cleaning process is controlled by low-power three-phase voltage pulses (5-20 Hz). An Electrodynamic Shield (EDS) or polyphase electric curtain system requires an external high voltage power supply to operate, but the EDS can be self-sustaining due to the power output of the solar cells themselves. This includes a transparent EDS with a solar battery as the power source to ensure sustainability. This process restored 90° reflectivity in just a few minutes..[13]

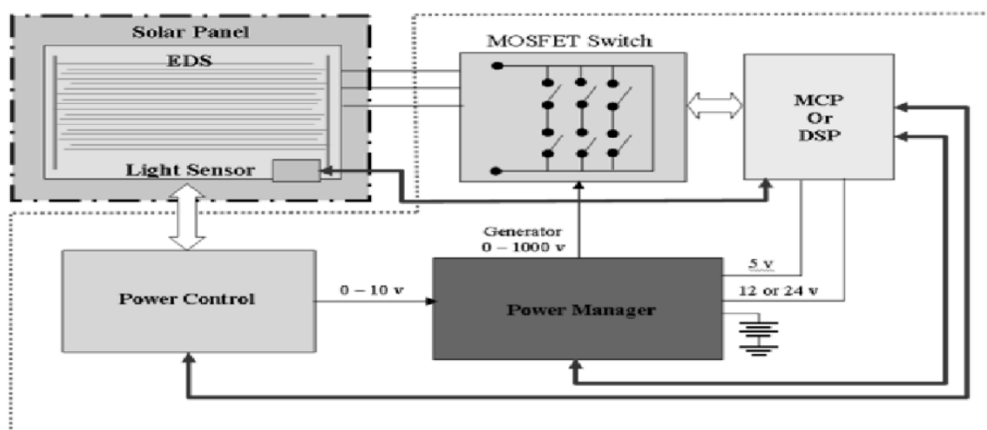

Fig .8 . Block diagram of EDS/PV array system [14]

Additionally, robotic cleaning mechanisms such as Sabot Swiss Innovations' Gekko Solar [15] and Gekko Solar Farm [16] are designed for mobile deployment of SPV panels as shown in the figure below. Gekko Solar has a cleaning capacity of up to 400m2 per hour. Clean with a rotating brush and demineralized water. It is supported by a mobile lifting platform. The operator uses a joystick to control the robot. It is fed from a support cart via a 50m hose and is based on a rotating vacuum technology leg on a two-tooth trapezoidal belt drive that allows the robot to move with incredible flexibility in a chosen direction. You can use the joystick to control it wirelessly.



Fig. 9 . Cleaning using Gekko solar and Gekko solar farm [17]

The Resola [18] robot differs from Sinfonia in that it is "autonomous" in that it is not tied to a rail and can move from panel to panel and handle dust and debris from the panel. The robot is equipped with a cleaning brush, glass cleaner, detergent and also sprays water from the tank. Robots can work even in the dark. There are LEDs with infrared wavelengths. 10:



Fig.10. Sinfonia Robot [18]

HECTOR [19] is Heliostat's robotic cleaning system that can be used to clean solar panels as shown below. It is wirelessly rechargeable and carries an aqueous solution reservoir. The HECTOR robot requires only operator intervention to fill the water tank, replace the battery and dispense throughout the installation. 11. The robot is coupled with various sensors that can move autonomously without human supervision. No external power or water is required for operation. He carries his own battery and water tank. HECTOR is designed for night and day operations. Its performance is very slow and the weight of HECTOR is over the panel. HECTOR performs a thorough, uniform, brush cleaning action.

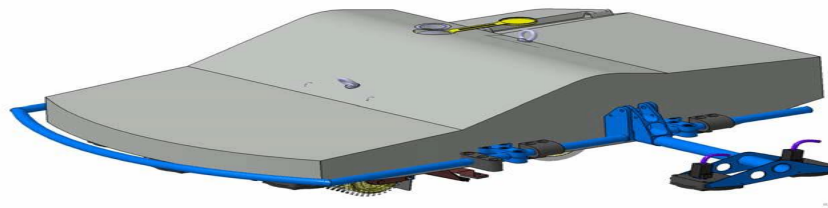

Fig. 11. Hector Robot [19]

A new four-step automatic "dry cleaning" method [20] for solar panels has been reported. The proposed cleaning process is performed in four steps without the use of liquids. The cleaning process includes blowing with compressed air followed by cleaning with a foam roller and synthetic polychlorinated cloth. An electronically controlled mechanical assembly grabs the rollers and guides them along with the solar panel. This system is very useful for both large and small installations, especially in dry areas with little or no rain all year round. The system consists of an onboard compressor that jets air to the panel. The panel is then cleaned with a rotating foam roller and synthetic dust roller. The system is controlled by an embedded microcontroller and can meet very low power requirements directly from the panel itself. Since no fluid supply is required, it is very cost-effective and effective for dry and hot environments such as Saudi Arabia, Qatar and the Middle East. Removable casters and easily accessible components make maintenance simple and very affordable. All these features make this system user-friendly. It should not be limited to large industrial plants and can equally be used in homes and small-scale solar panels and solar panel construction.

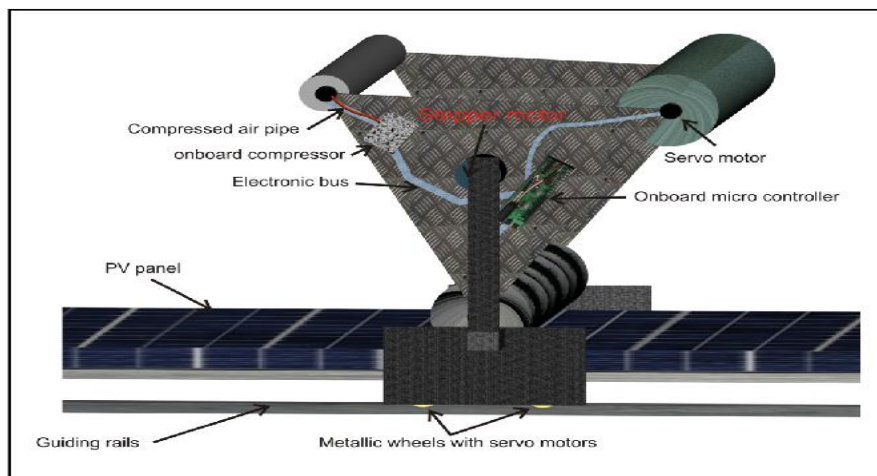

Fig. 12 . Novel dry cleaning assembly for cleaning [20]

9. Conclusions

Many factors determine the ideal power or optimal output of a PV module. The environment is one of the factors that directly affect solar performance. In this article, we investigated the partial shading of photovoltaic modules (PV) by soil accumulated on the PV surface. Effects on voltage (DC) and current (DC) have been discussed for shading due to pollution. There are generally two types of soil shading for PV modules, these are known as hard shading and soft shading..

- The amount of accumulated dust on the surface of the PV module affects the overall energy delivered from the PV module on a daily, monthly, seasonal and annual basis
- There are two interdependent parameters that affect the accumulation characteristics of solar panels, dust penetration, and the local environment.
- Sometimes dirt stains such as leaves, bird droppings and dirt stains that block some cells in the PV module but not completely

The research presented in this chapter presents a graph of the concepts and projects that have been made to date. These systems are intended for research or commercial use. Considering the various conventional solar panel cleaning methods above and their advantages and limitations, it can be concluded that brushed solar panel cleaning is ideal as it does not require water or small amounts of water to remove dust. It's also cheap and you can design your own. It also operates and is considered as an auxiliary unit of the existing solar PV system. However the total power consumes for the removal of dust, the percentage of dust removal, frequency of operations, the speed of the dust removing mechanism, economics, durability, reliability, etc of the dust-removal mechanism and its components are required to be tested.

References

References

- 1) Ilse, K.K.; Figgis, B.W.; Naumann, V.; Hagendorf, C.; Bagdahn, J. Fundamentals of soiling processes on photovoltaic modules. *Renew. Sustain. Energy Rev.* 2018, 98, 239–254.
- 2) Sarver, T.; Al-Qaraghuli, A.; Kazmerski, L. A Comprehensive Review of The Impact of Dust on The Use of Solar Energy: History, Investigations, Results, Literature, and Mitigation Approaches. 2013. Available online: https://ideas.repec.org/a/eee/rensus/v2_2y2013icp698-733.html (accessed on 16 October 2020).
- 3) Ilse, K.; Micheli, L.; Figgis, B.W.; Lange, K.; Daßler, D.; Hanifi, H.; Wolfertstetter, F.; Naumann, V.; Hagendorf, C.; Gottschalg, R. Techno-Economic Assessment of Soiling Losses and Mitigation Strategies for Solar Power Generation. *Joule* 2019, 3, 2303–2321.
- 4) Jacobson MZ, Delucchi MA, Providing all global energy with wind, water, and solar power. Part I: Technologies, energy resources, quantities and areas of infrastructure, and materials. *Energy Policy*. vol.39:p.1154–1169.
- 5) Xiao W, Dunford WG, A modified adaptive hill climbing MPPT method for photovoltaic power systems. in: Proceedings of 2004 IEEE 35th annual power electronics specialists conference. PESC04; 2004. p.1957–1963.
- 6) Wenham SR. *Applied photovoltaics*. New York: Routledge; 2011
- 7) Herrmann W, Wiesner W, Vaassen W, Hot spot investigations on PV modules new concepts for a test standard and consequences for module design with respect to bypass diodes. In: Photovoltaic Specialists Conference. 1997, Conference Record of the Twenty-Sixth IEEE; 1997. p. 1129–1132.
- 8) Hajighorbani S, Radzi M, Ab Kadir M, Shafie S, Khanaki R, Maghami M. Evaluation of Fuzzy Logic Subsets Effects on Maximum Power Point Tracking for Photovoltaic System. *Int J Photoenergy* 2014;2014.
- 9) Hottel H, Woertz B. Performance of flat-plate solar-heat collectors. *Trans. ASME* 1942;64

- 10) Mani M, Pillai R. Impact of dust on solar photovoltaic (PV) performance: Research status, challenges and recommendations. *Renew Sustain Energy Rev* 2010;14:3124–31.
- 11) El-Shobokshy MS, Hussein FM. Degradation of photovoltaic cell performance due to dust deposition on to its surface. *Renew Energy* 1993;3:585–90.
- 12) PHOTOVOLTAIC SOLAR ENERGY Development and current research, www.energy.eu
- 13) Sayyah, A, Horenstein M., and Mazumder M. "Mitigation of Soiling Losses in Concentrating Solar Collectors." 2013 IEEE 39th Photovoltaic Specialists Conference (PVSC) (2013): 404-408. Print
- 14) Bock JP, Robison JR, Sharma R, Zhang J, Mazumder MK. "An efficient power management approach for self-cleaning solar panels with integrated electrodynamic screens." In: Proc. ESA Annual Meeting on Electrostatics 2008; Minneapolis, MN, Paper O2
- 15) Serbot Swiss Innovations. Gekko solar; http://serbot.ch/images/documents/TD_GEKKO%20Solar_En_2013_06_06.pdf.
- 16) Serbot Innovations. Gekko solar farm; Available from: http://serbot.ch/images/documents/TD_GEKKO%20Solar%20Farm_En_2013_06_26.pdf
- 17) EUROSERVER Photovoltaic barometer, 2016. <https://www.euroserver.org/photovoltaic-barometer-2016/>
- 18) Sinfonia's robot, Available from: <http://www.renewableenergyworld.com/articles/2014/11/from-module-cleaning-robots-to-flyingdrones-japans-growing-solar-o-m-market.html>
- 19) HECTOR – Cleaning robot system for Heliostats; <http://www.seneraerospace.com/AEROESPACIAL/ProjectsD/hectorcleaning-brobot-system-for-heliostats/en>.
- 20) Shahzada Pamir Aly, Palanichamy Gandhidasan “Novel Dry Cleaning Machine for Photovoltaic and Solar Panels” Qatar Environment and Energy Research Institute (QEERI), Hamad Bin Khalifa University (HBKU), Qatar Foundation PO Box 5825, Doha, Qatar. 2015 IEEE.