



An interactive weighted fuzzy goal programming technique to solve multi-objective reliability optimization problem

Tanmay Kundu¹ · Sahidul Islam¹

Received: 19 February 2017 / Accepted: 17 July 2019 / Published online: 26 July 2019
© The Author(s) 2019

Abstract

This paper presents an application of interactive fuzzy goal programming to the nonlinear multi-objective reliability optimization problem considering system reliability and cost of the system as objective functions. As the decision maker always have an intention to produce highly reliable system with minimum cost, therefore, we introduce the interactive method to design a high productivity system here. This method plays an important role to maximize the worst lower bound to obtain the preferred compromise solution which is close to the best upper bound of each objective functions. Until the preferred compromise solution is reached, new lower bounds corresponding to each objective functions will be determined based on the present solution to develop the updated membership functions as well as aspiration levels to resolve the proposed problem. Considering judgmental vagueness of decision maker, here we consider the resources as trapezoidal fuzzy numbers and apply total integral value of fuzzy number to transform into crisp one. To illustrate the methodology and performance of this approach, numerical examples are presented and evaluated by comparing with the other method at the end of this paper.

Keywords Reliability · Fuzzy programming · Multi-objective programming · Interactive methods · Goal programming

Introduction

Since 1960, reliability engineering is one of the most important tasks in designing and development of a technical system. The primary goal of reliability engineer is always to find the best route to increase the system reliability. The diversity of system resources, resource constraints, and options for reliability improvement leads to the construction and analysis of several optimization models. The majority of reliability optimization models discussed in the various literatures. For example, Misra (1971) discussed the application of integer programming to solve reliability optimization problems. Later Kuo and Prasad (2000) and Kuo et al. (2001) presented some suitable method for solving reliability optimization models. In recent time, Hao et al. (2017) proposed an efficient and robust algorithm of non-probabilistic reliability-based design optimization (NRBDO). Later an efficient and accurate RBDO framework based on

iso-geometric analysis (IGA) for complex engineering problems is established by Hao et al. (2019).

In real life system, due to some uncertainty factors in judgments of decision maker (DM), definitely it is not always possible to get consequential data for the reliability optimization model, as there are some coefficients and parameters which are always imprecise due to the vagueness of nature. In order to handle the vague judgments of DM in multi-objective problems, which may be classified as a non-stochastic imprecise model, fuzzy approach can be used to solve this model. Some researchers have also used fuzzy technique to solve multi-objective reliability optimization problems. At first, Park (1987) applied fuzzy optimization techniques to solve the problem of reliability apportionment for a series system. A multi-objective formulation of reliability allocation problem to maximize system reliability and minimize system cost has been described by Sakawa (1978) using surrogate worth trade methods. In recent time, Grag (2013) applied particle swarm optimization method to solve a fuzzy multi-objective reliability optimization problem. Dancese et al. (2014) studied reliability and cost analysis of a series system model using fuzzy parametric geometric programming. Wang et al. (2017) proposed a

✉ Tanmay Kundu
tanmaykundu.math@gmail.com

¹ Department of Mathematics, University of Kalyani, Kalyani, West Bengal 741235, India

novel reliability-based optimization model and method for thermal structure design in fuzzy environment.

There are various kinds of optimization techniques which can be used to solve nonlinear optimization problems. Goal programming (GP) is one of the effective methods among those to solve a particular type of nonlinear programming problem. GP has been widely applied to solve different types of real-world problems which involve multiple objectives. After applying GP, the DM can obtain a satisfactory solution and also can able to analyze the aspiration levels. Dhingra (1992) used GP to solve multi-objective reliability apportionment problem in fuzzy environment. Gen and Ida (1993) also discussed the application of large-scale 0–1 fuzzy goal programming to solve reliability optimization problem. Later, Hwang and Lee (2009) provides an algorithm for non-linear integer goal programming using branch-and-bound method and its application of this algorithm to demonstrate the solving procedure of reliability problems with single and multiple objectives.

In this paper, we are going to introduce a fuzzy multi-objective mathematical programming problem in which system reliability and cost of the system are to be considered as two objective functions. The goal of the present study is to apply an efficient and modified optimization technique to find preferred compromise solution (Leberling 1981) of the proposed model. This is very rare to use interactive weighted fuzzy goal programming (IWFGP) in reliability optimization model. Hence we choose IFGP technique as the solution procedure of the proposed optimization model to design a high productivity system. Wahed and Lee (2006) presented interactive fuzzy goal programming approach to solve multi-objective transportation model. Sakawa and Matsui (2012) and Sinna and Abo-Elnaga (2014) also used interactive approach to solve multi-objective programming under fuzzy environment.

In other existing method like fuzzy multi-objective goal programming (FMOGP) method (Hwang and Lee 2004; Zangiabadi and Maleki 2007), initially the objective goal and the maximum tolerances for resources should

be given. In the real-world situations, it is unrealistic to initially ask the decision maker (DM) to give goal and tolerances without providing any information about them. Therefore, the obtained solution may not be satisfactory for the DM. But interactive method considers a large variety of situations that the DM might meet when solving a nonlinear programming problem. In this paper, the proposed interactive approach focuses on maximizing the worst lower bound to obtain the preferred compromise solution which is close to the best upper bound of each objective functions. Updating both the membership values and the aspiration levels during the solution procedure, it controls the search direction. As a result, preferences of DM achieve the efficient solution. This process continues until the decision maker satisfied with the solution. Hence clearly this method gives a highly reliable system compared to other existing methods.

The paper is organized as follows: In “**Mathematical model**” section, a reliability model of a LCD display unit is considered and develop a multi-objective problem for evaluation; “**Prerequisite mathematics**” section defines some basic definitions related to fuzzy set; in “**Interactive weighted fuzzy goal programming (IWFGP) method**” section, IWFGP method is introduced; “**Interactive weighted fuzzy goal programming technique on multi-objective fuzzy reliability optimization problem**” section provides IWFGP method for solving the proposed reliability model; in “**Numerical example**” section, numerical examples are solved and compared with the existing methods. Finally, the conclusions are drawn in “**Conclusion**” section.

Mathematical model

Let R_j be the reliability of the j th component of a system and $R_S(R)$ be the system reliability. Let $C_S(R)$ denotes the cost of the system. Here we consider a complex system which includes a five-stage combination reliability model (Fig. 1).

Fig. 1 Reliability model of a LCD display unit

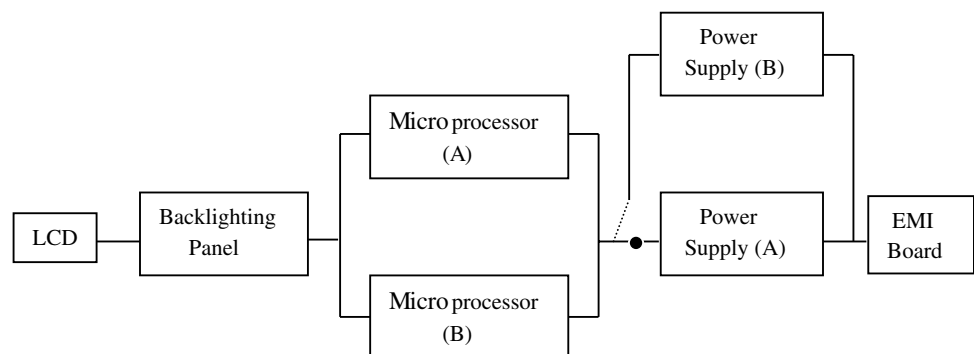

Reliability model of a LCD display unit

Now we are interested to find out the system reliability of a LCD display unit (Neubeck 2004; Mahapatra and Roy 2010) which consists of several components connected to one another. This complex system mainly consists of five stages L_i , ($i = 1, 2, \dots, 5$) which are in series. Thus the generalized formula for the system reliability of the proposed model is given by

$$R_S(R) = L_1 \times L_2 \times L_3 \times L_4 \times L_5 = \prod_{j=1}^5 L_j \tag{1}$$

Here

- L_1 : LCD panel with reliability R_1 , i.e., $L_1 = R_1$;
- L_2 : A backlighting board containing 10 bulbs with individual bulb reliability R_2 such that the board function with at most one bulb failure, i.e., $L_2 = R_2^{10} + 10R_2^9(1 - R_2)$;
- L_3 : Two microprocessor boards A and B hooked up in parallel, each of reliability R_3 , i.e., $L_3 = 1 - (1 - R_3)^2$;
- L_4 : Dual power supplies in standby redundancy, each power supply of reliability R_4 , i.e., $L_4 = R_4 + R_4 \ln(1/R_4)$;
- L_5 : EMI board with reliability R_5 hooked in series with common input of the power supply A , i.e., $L_5 = R_5$;

Thus we have the following system reliability

$$R_S(R) = R_1(R_2^{10} + 10R_2^9(1 - R_2)) \left(1 - (1 - R_3)^2\right) \times (R_4 + R_4 \ln(1/R_4))R_5 \tag{2}$$

Multi-objective reliability optimization model (MOROM)

Here we consider the cost of the proposed complex system as an additional objective function. Therefore, the system reliability and the cost of the system are to be maximized and minimized, respectively subject to system space as target goal. Thus the model becomes

$$\begin{aligned} \text{Max } R_S(R) &= R_1(R_2^{10} + 10R_2^9(1 - R_2)) \left(1 - (1 - R_3)^2\right) \\ &\quad \times (R_4 + R_4 \ln(1/R_4))R_5 \\ \text{Min } C_S(R) &= \sum_{j=1}^5 c_j \left[\tan\left(\frac{\pi}{2}\right)R_j\right]^{\alpha_j} \\ \text{s.t. } V_S(R) &= \sum_{j=1}^5 v_j R_j^{\alpha_j} \leq V_{\text{lim}} \\ 0.5 \leq R_{j,\text{min}} \leq R_j \leq 1, 0 \leq R_S \leq 1; j &= 1, 2, \dots, 5 \end{aligned} \tag{3}$$

Here v_j and c_j represent the space and cost of the j th component of the system, respectively. V_{lim} is the system space limitation and $R_{j,\text{min}}$ is the lower bound of the reliability of each component j .

Now to simplify the calculation and to convert the above problem to one type maximization problem, we consider

$$C'_S(R) = -C_S(R)$$

Thus model (3) has the following form

$$\begin{aligned} \text{Max } R_S(R) \\ \text{Max } C'_S(R) \end{aligned} \tag{4}$$

subject to the same constraints defined in (3)

Multi-objective fuzzy reliability optimization model

In general the coefficients of cost parameters, resources of constraints are not always be specified by relevant precise data and has always been imprecise and vague in nature. This type of imprecise data is not always well represented by random variable selected from a probability distribution. But fuzzy number may represent these data. Here we consider space goal V_{lim} as trapezoidal fuzzy number which can be expressed as $\tilde{V}_{\text{lim}} = (V_{1L}, V_{2L}, V_{3L}, V_{4L})$. Thus the above problem (4) reduces to the following fuzzy problem as

$$\begin{aligned} \text{Max } R_S(R) &= R_1(R_2^{10} + 10R_2^9(1 - R_2)) \left(1 - (1 - R_3)^2\right) \\ &\quad \times (R_4 + R_4 \ln(1/R_4))R_5 \\ \text{Max } C'_S(R) &= - \sum_{j=1}^5 c_j \left[\tan\left(\frac{\pi}{2}\right)R_j\right]^{\alpha_j} \\ \text{s.t. } V_S(R) &= \sum_{j=1}^5 v_j R_j^{\alpha_j} \leq \tilde{V}_{\text{lim}} \\ 0.5 \leq R_{j,\text{min}} \leq R_j \leq 1, 0 \leq R_S \leq 1; j &= 1, 2, \dots, 5 \end{aligned} \tag{5}$$

Prerequisite mathematics

Definition 3.1 A fuzzy set \tilde{A} in X is a set of ordered pairs (Zadeh 1965 first introduced the fuzzy set theory):

$$\tilde{A} = \{(x, \mu_{\tilde{A}}(x)) | x \in X\},$$

where X is a collection of objects denoted generically by x and $\mu_{\tilde{A}}(x) : X \rightarrow [0, 1]$ is called the membership function or grade of membership of x in \tilde{A} .

Definition 3.2 Chen (Chen 1985) represents a generalized trapezoidal fuzzy number (GTrFN) \tilde{A} as $\tilde{A} = (a, b, c, d; w)$, where $0 < w \leq 1$, and a, b, c , and d are real numbers. The

generalized fuzzy number \tilde{A} is a fuzzy subset of real line \mathbb{R} , whose membership function $\mu_{\tilde{A}}(x) : \mathbb{R} \rightarrow [0, w]$ is defined as

$$\mu_{\tilde{A}}^w(x) = \begin{cases} \mu_{L\tilde{A}}^w(x) = w \frac{x-a}{b-a}, & a \leq x \leq b; \\ w, & b \leq x \leq c; \\ \mu_{R\tilde{A}}^w(x) = w \frac{x-d}{c-d}, & c \leq x \leq d; \\ 0, & \text{otherwise} \end{cases} \quad (6)$$

Note: \tilde{A} is a normalized fuzzy number when $w = 1$, and it is non-normalized for $w \neq 1$ (Fig. 2).

Here $\mu_{L\tilde{A}}^w$ and $\mu_{R\tilde{A}}^w$ are the left and right membership functions of \tilde{A} respectively.

And the inverse functions $h_{L\tilde{A}}^w : [0, w] \rightarrow [a, b]$ and $h_{R\tilde{A}}^w : [0, w] \rightarrow [c, d]$ are defined as

$$h_{L\tilde{A}}^w(y) = a + \frac{(b-a)}{w}y; \quad (7)$$

$$h_{R\tilde{A}}^w(y) = d + \frac{(c-d)}{w}y; \quad y \in [0, w].$$

Now according to integral value method of Liou’s (Liou and Wang 1992) we have, for a non-normal fuzzy number \tilde{A} , the corresponding membership function $f_{\tilde{A}}(x)$ can be normalized by dividing the maximal value of $f_{\tilde{A}}(x)$, i.e., w and let \tilde{A} and $\tilde{f}_{\tilde{A}}$ are normalized fuzzy number and the corresponding membership function.

Let $k \in [0, 1]$ be the index of optimism which represent the degree of optimism of a decision maker (DM). then the total k -integral value is defined as

$$I_k^w(\tilde{A}) = [kI_R^w(\tilde{A}) + (1-k)I_L^w(\tilde{A})]$$

where $I_{wR}(\tilde{A})$ and $I_{wL}(\tilde{A})$ represent the right and left integral values of \tilde{A} , respectively. Now, when \tilde{A} being ranked, using the result discussed in Liou and Wang (1992), we have

$$I_L^w(\tilde{A}) = \int_0^1 h_{L\tilde{A}}^w(wy)dy = \frac{1}{2}(a+b)$$

$$\text{and } I_R^w(\tilde{A}) = \int_0^1 h_{R\tilde{A}}^w(wy)dy = \frac{1}{2}(c+d)$$

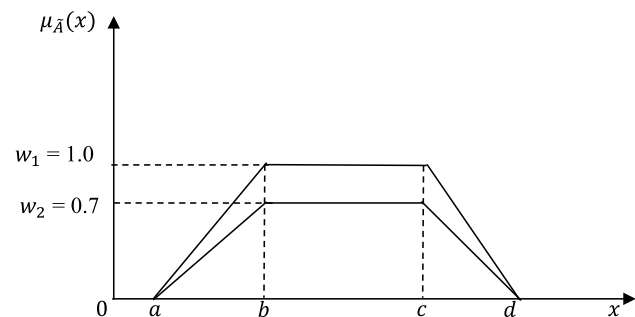

Fig. 2 Generalized trapezoidal fuzzy number

Thus, $I_k^w(\tilde{A}) = \frac{1}{2}[k(c+d) + (1-k)(a+b)]$ which does not depend on the value of w , i.e., whether \tilde{A} is normal or not. A larger value of k indicates the higher degree of optimism. Now for $k=0$, the total k -integral value is $I_0^w(\tilde{A}) = \frac{1}{2}(a+b) = I_L^w(\tilde{A})$, represents a pessimistic viewpoint of a DM and for optimistic DM’s viewpoint, i.e., for $k=1$, $I_1^w(\tilde{A}) = \frac{1}{2}(c+d) = I_R^w(\tilde{A})$. When $k=0.5$, the total k -integral value $I_{0.5}^w(\tilde{A}) = \frac{1}{2}[I_R^w(\tilde{A}) + I_L^w(\tilde{A})]$ reflects a moderately optimistic DM’s viewpoint.

Interactive weighted fuzzy goal programming (IWFGP) method

The interactive method is an efficient and modified optimization technique and gives a highly reliable system than other existing methods. At the time of solving a nonlinear programming problem, interactive method considers a large variety of situations that the decision maker (DM) might meet. In this method DM can modify the original model continuously to obtain a satisfactory solution until the decision maker will be satisfied with the obtained result at each stage.

Here we are presenting a solution procedure to solve multi-objective reliability optimization problem (MOROP) by interactive weighted fuzzy goal programming technique and the following steps are used

Step 1 Construct a fuzzy multi-objective nonlinear programming problem considering k objective functions as

$$\begin{aligned} &\text{Maximize } (f_1(x), f_2(x), \dots, f_k(x)) \\ &\text{Subject to, } g_i(x) \leq \tilde{b}_i, \quad i = 1, 2, \dots, m; \quad x \geq 0; \end{aligned} \quad (8)$$

Step 2 Solve the fuzzy multi-objective nonlinear programming problem taking only one objective function at a time and avoid the others, so that we can get the ideal solutions. If all the solutions are the same, select one of them as an optimal compromise solution and go to step 10. Otherwise go to step 3.

Step 3 With the values of all objective functions evaluated at these ideal solutions, the payoff matrix can be formulated as follows (Table 1)

Step 4 Determine the best upper bound and the worst lower bound for constructing the membership function as follows

$$U_r = \max \{f_r(x^1), f_r(x^2), \dots, f_r(x^k)\} \quad \forall r = 1, 2, \dots, k$$

$$\text{and } L_r = \min \{f_r(x^1), f_r(x^2), \dots, f_r(x^k)\} \quad \forall r = 1, 2, \dots, k$$

So, $L_r \leq f_r(x) \leq U_r$

Here L_r and U_r are, respectively, lower and upper bounds of the r th objective function $f_r(x)$, $\forall r = 1, 2, \dots, k$.

Step 5 Construct the membership functions of each objective functions as follows

Table 1 Payoff matrix of the solution of (8)

	f_1	f_2	...	f_k
x^1	$f_1^*(x^1)$	$f_2(x^1)$...	$f_k(x^1)$
x^2	$f_1(x^2)$	$f_2^*(x^2)$...	$f_k(x^2)$
\vdots	\vdots	\vdots		\vdots
x^k	$f_1(x^k)$	$f_2(x^k)$...	$f_k^*(x^k)$

$$\mu_r^{w_r}(f_r(x)) = \begin{cases} 0 & \text{if } f_r(x) < L_r; \\ w_r \frac{f_r(x) - L_r}{U_r - L_r} & \text{if } L_r \leq f_r(x) \leq U_r; \\ w_r & \text{if } U_r < f_r(x); \end{cases} \quad \forall r = 1, 2, \dots, k. \tag{9}$$

and

$$\mu_r(g_i(x)) = \begin{cases} 0 & \text{if } b_i + p_i < g_i(x); \\ 1 - \frac{g_i(x) - b_i}{p_i} & \text{if } b_i \leq g_i(x) \leq b_i + p_i; \\ 1 & \text{if } g_i(x) < b_i; \end{cases} \quad \forall i = 1, 2, \dots, m. \tag{10}$$

U_r is the best upper bound and L_r is the worst lower bound of the r th objective functions, respectively.

Step 6 Now based on the max–min operator introduced by Bellman and Zadeh (1970), the following decision making is defined as

$$\text{fuzzy decisions } (D) = \text{fuzzy objective goals } (G) \cap \text{fuzzy constraints } (C)$$

Thus, the membership function is characterized by

Now, if(i) $f_k^* > L_k$, then L_k is replaced by f_k^* .

if(ii) $f_k^* > L_k$, then keep these aspiration level same.

and if(iii) $f_k^* = U_k$, then replace L_k by U_k and keep them until the solution procedure is terminated.

$$\mu_D(x) = \min(\mu_G(x), \mu_C(x))$$

Introducing the variable λ , where

$$\begin{aligned} \lambda &= \min[\mu_1^{w_1}(f_1(x)), \dots, \mu_k^{w_k}(f_k(x))] \\ &= \min[\mu_1^w(f_1(x)), \dots, \mu_k^w(f_k(x))] \\ &= \min[w\mu_1(f_1(x)), \dots, w\mu_k(f_k(x))] \quad \text{Where, } w = \min(w_1, w_2, \dots, w_k) \\ &= \min_r(w_r), \text{ for } r = 1, 2, \dots, k. \end{aligned}$$

Step 7 Obtain a preferred solution by solving the following problem:

$$\begin{aligned} &\text{Maximize } \lambda \\ \text{Subject to, } &w\mu_r(f_r(x)) \geq \lambda; \quad \forall r = 1, 2, \dots, k; \\ &\mu_i(g_i(x)) \geq \lambda; \quad \forall i = 1, 2, \dots, m; \\ &\lambda \in [0, w] \text{ and } x \geq 0, w \in (0, 1] \end{aligned} \tag{11}$$

Now using positive weights W_r ($r = 1, 2, \dots, k$) for the objectives $f_r(x)$, we have

$$\begin{aligned} &\text{Maximize } \lambda \\ \text{Subject to, } &W_r w\mu_r(f_r(x)) \geq \lambda; \quad \forall r = 1, 2, \dots, k; \\ &\mu_i(g_i(x)) \geq \lambda; \quad \forall i = 1, 2, \dots, m; \\ &\lambda \in [0, w] \text{ and } x \geq 0, w \in (0, 1], \sum_{r=1}^k W_r = 1. \end{aligned} \tag{12}$$

Here positive weights W_r ($r = 1, 2, \dots, k$) reflect the decision maker’s preferences regarding the relative importance of each objective goal.

Step 8 Now to convert the problem to a nonlinear goal programming problem, positive and negative deviational variables δ_k^+ and δ_k^- are introduced, respectively. Thus the goal programming problem is as follows

$$\begin{aligned} &\text{Maximize } \lambda \\ \text{Subject to, } &W_r w\mu_r(f_r(x)) \geq \lambda; \quad \forall r = 1, 2, \dots, k; \\ &\mu_i(g_i(x)) \geq \lambda; \quad \forall i = 1, 2, \dots, m; \\ &f_r(x) - \delta_k^+ + \delta_k^- = G_r \\ &x, \delta_k^+, \delta_k^- \geq 0, \quad r = 1, 2, \dots, k; \\ &\lambda \in [0, w] \text{ and } w \in (0, 1], \sum_{r=1}^k W_r = 1. \end{aligned} \tag{13}$$

where G_r is the aspiration level of r th objective function.

Step 9 Evaluate each objective function corresponding to the solution vector R^* and find $f_1^*, f_2^*, \dots, f_k^*$.

If the preferred solution obtained from (13) is satisfactory for the decision maker (DM), then the process is success-

fully concluded and go to step 10. Otherwise go to step 5 and repeat the process.

Step 10 Stop.

There are some restrictions on modifying the membership functions of objectives and fuzzy constraints (See “Appendix”).

Interactive weighted fuzzy goal programming technique on multi-objective fuzzy reliability optimization problem

To solve the above defined model (5), using “Interactive weighted fuzzy goal programming (IWFGP) method” section payoff matrix is formulated as follows:

	$R_S(R)$	$C'_S(R)$
R^1	$R_S^*(R^1)$	$C'_S(R^1)$
R^2	$R_S(R^2)$	$C'_S(R^2)$

Now the best upper bound and worst lower bound are identified, which are given by U_1, U_2 , and L_1, L_2 , respectively.

$$\text{Where } L_1 \leq R_S(R) \leq U_1; \quad L_2 \leq C'_S(R) \leq U_2$$

$$U_1 = \max\{R_S(R^1), R_S(R^2)\}; \quad U_2 = \max\{C'_S(R^1), C'_S(R^2)\}$$

$$L_1 = \min\{R_S(R^1), R_S(R^2)\}; \quad L_2 = \min\{C'_S(R^1), C'_S(R^2)\}$$

Now the linear membership functions for the objectives $R_S(R), C_S(R)$ and constraint $V_S(R)$ are defined as follows:

$$\mu_{R_S}^{w_1}(R_S(R)) = \begin{cases} 0 & \text{if } R_S(R) < L_1; \\ w_1 \left(\frac{R_S(R) - L_1}{U_1 - L_1} \right) & \text{if } L_1 \leq R_S(R) \leq U_1; \\ w_1 & \text{if } U_1 < R_S(R); \end{cases} \quad (14)$$

$$\mu_{C'_S}^{w_2}(C'_S(R)) = \begin{cases} 0 & \text{if } C'_S(R) < L_2; \\ w_2 \left(\frac{C'_S(R) - L_2}{U_2 - L_2} \right) & \text{if } L_2 \leq C'_S(R) \leq U_2; \\ w_2 & \text{if } U_2 < C'_S(R); \end{cases} \quad (15)$$

and

$$f_{V_S}(V_S(R)) = \begin{cases} 0 & \text{if } V_{lim} + d_{V_S} < V_S(R); \\ 1 - \left(\frac{V_S(R) - V_{lim}}{d_{V_S}} \right) & \text{if } V_{lim} \leq V_S(R) \leq V_{lim} + d_{V_S}; \\ 1 & \text{if } V_S(R) < V_{lim}; \end{cases} \quad (16)$$

After electing the membership functions, the crisp model is formulated as follows

Maximize λ

Subject to,

$$W_1 w \left(\frac{R_S(R) - L_1}{U_1 - L_1} \right) \geq \lambda;$$

$$W_2 w \left(\frac{C'_S(R) - L_2}{U_2 - L_2} \right) \geq \lambda;$$

$$d_{V_S}(1 - \lambda) - \sum_{j=1}^5 v_j R_j^{a_j} - (I(V_{lim})) \geq 0;$$

$$0.5 \leq R_{j,min} \leq R_j \leq 1, 0 \leq R_S \leq 1; \lambda \in [0, w] \text{ and } w \in (0, 1], \sum_{r=1}^2 W_r = 1. \quad (17)$$

Here $I(V_{lim})$ denote the integral value of the space limitation of the system (Fig. 3).

Now from the above problem, we have the goal programming problem is as follows

Maximize λ

Subject to,

$$W_1 w \left(\frac{R_S(R) - L_1}{U_1 - L_1} \right) \geq \lambda;$$

$$W_2 w \left(\frac{C'_S(R) - L_2}{U_2 - L_2} \right) \geq \lambda;$$

$$d_{V_S}(1 - \lambda) - \sum_{j=1}^5 v_j R_j^{a_j} - (I(V_{lim})) \geq 0;$$

$$R_S(R) - \delta_{R_S}^+ + \delta_{R_S}^- = G_{R_S};$$

$$C'_S(R) - \delta_{C_S}^+ + \delta_{C_S}^- = G_{C_S};$$

$$0.5 \leq R_{j,min} \leq R_j \leq 1, 0 \leq R_S \leq 1; \lambda \in [0, w] \text{ and } w \in (0, 1], \sum_{r=1}^2 W_r = 1.$$

$$\delta_{R_S}^+, \delta_{R_S}^-, \delta_{C_S}^+, \delta_{C_S}^- \geq 0; \quad (18)$$

Numerical example

Now a five-stage combination reliability model of a complex system is considered for numerical exposure. The problem becomes as follows (Table 2):

$$\text{Max } R_S(R) = R_1 (R_2^{10} + 10R_2^9(1 - R_2)) \left(1 - (1 - R_3)^2 \right) \times (R_4 + R_4 \ln(1/R_4)) R_5$$

$$\text{Min } C_S(R) = \sum_{j=1}^5 c_j \left[\tan \left(\frac{\pi}{2} \right) R_j \right]^{a_j}$$

$$\text{s.t. } V_S(R) = \sum_{j=1}^5 v_j R_j^{a_j} \leq V_{lim}$$

$$0.5 \leq R_{j,min} \leq R_j \leq 1, 0 \leq R_S \leq 1; j = 1, 2, \dots, 5 \quad (19)$$

Here we consider the resource V_{lim} as triangular fuzzy number and taking the fuzzy input data as $\tilde{V}_{lim} = (23.5, 24.5, 26.5, 27.5)$ for $k=0.5$ and for each objective function solution vectors is given by (Table 3)

$$R^1 = (0.999999, 0.996198, 0.872375, 0.815615, 0.999999) \text{ and } R^2 = (0.500000, 0.500000, 0.500000, 0.500000, 0.500000)$$

Now the upper and lower bound are given by (Table 4) $U_1 = 0.9652396, U_2 = -156.059; L_1 = 0.0017051, L_2 = -5442.103$; and can be written as $0.0017051 \leq R_S(R) \leq 0.9652396$ and $-5442.103 \leq C'_S(R) \leq -156.059$;

The membership functions of objectives and constraints are formulated and solving the goal programming problem (18) using LINGO package we have

Fig. 3 The whole procedure of the proposed model

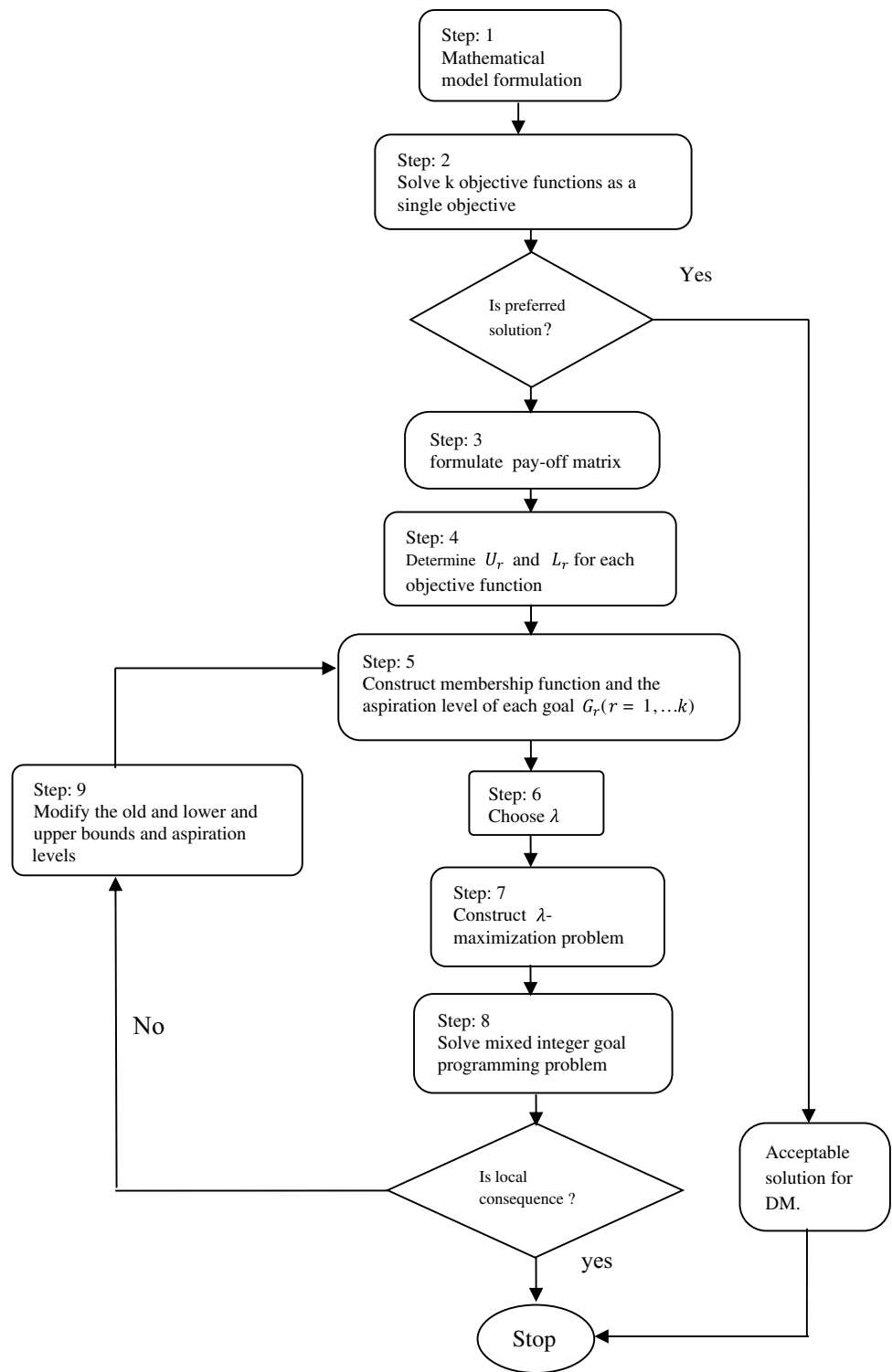

Table 2 The input data for the MOROM (19)

c_1	c_2	c_3	c_4	c_5	v_1	v_2	v_3	v_4	v_5	$\alpha_j(\forall j)$	$\alpha_j(\forall j)$	V_{lim}
30	25	28	35	38	7	4.80	3.75	3	8	0.6	1	25.5

Table 3 Payoff matrix of the solution of (19)

	$R_S(R)$	$C'_S(R)$
R^1	0.9652396	− 5442.103
R^2	0.001705135	− 156.059

where ρ is a distance parameter and $1 \leq \rho \leq \infty$. d_r represents the degree of closeness of the preferred compromise solution to the optimal solution vector of the r th objective function

i.e. $d_r = \frac{\text{the optimal solution of } r\text{th objective function}}{\text{the preferred compromise solution of } r\text{th objective function}}$

The new upper and lower bound are $0.206754 \leq R_S(R) \leq 0.9652396$ and $-3964.032 \leq C'_S(R) \leq -156.059$. Thus the new aspiration levels of the two objective functions are 0.206754 and − 3964.032, respectively. Assume that the decision maker (DM) is not satisfied with this solution and needs more satisfactory solution and thus according to discussion on modification of membership function in “Interactive weighted fuzzy goal programming (IWFGP) method” section, DM modified and resolved the model and will get the following compromise solution (Table 5):

Now if the DM considers this solution as preferred compromise solution, then the procedure is terminated, but if not, then the process will continue until DM will accept the result. Thus we have the following set of compromise solutions $(R_S(R), C'_S(R))$ as: (0.0017051, − 5442.103), (0.206754, − 3964.032), (0.605869, − 2469.679), (0.820822, − 2017.214), (0.869041, − 1184.530), (0.959681, − 619.152), respectively.

Thus the proposed interactive weighted fuzzy goal programming (IWFGP) method gives the preferred compromise solution as $R_S(R) = 0.959681$ and $C'_S(R) = -619.152$.

According to Wahed and Lee (2006), to determine the degree of closeness of the result obtained by IWFGP approach results to the ideal solution, we define the following distance functions (Steuer 1986) as

$$D_\rho(\beta, K) = \left[\sum_{r=1}^K \beta_r^\rho (1 - d_r)^\rho \right]^{1/\rho} \tag{20}$$

$\beta = (\beta_1, \beta_2)$ is the vector of objectives aspiration levels and $\sum_{L=1}^2 \beta_L = 1$. Now for $\rho = 1, 2$ and ∞ we have the distance functions as follows:

- (i) $D_1(\beta, K) = 1 - \sum_{r=1}^K \beta_r d_r$
- (ii) $D_2(\beta, K) = \left[\sum_{r=1}^K \beta_r^2 (1 - d_r)^2 \right]^{1/2}$
- (iii) $D_\infty(\beta, K) = \max_r \{ \beta_r (1 - d_r) \}$ (21)

In the given numerical example we take $\beta_1 = \beta_2 = 0.5$, (i.e., the objectives are equally important) and compare the solution of (19) with different approaches.

From Table 6, it is clear that the suggested approach gave a better preferred compromise solution and also in D_1, D_2 and D_∞ compared to the solution obtained by intuitionistic fuzzy approach in Mahapatra and Roy (2010) and FMOGP method.

Conclusion

Here we introduced interactive fuzzy-weighted goal programming method to find the preferred compromise solution of the proposed multi-objective reliability optimization model. Also here we consider the resources as trapezoidal fuzzy number and used the total integral value of fuzzy number to convert into crisp number. The main advantage of interactive approaches is that the DM controls the search

Table 4 First modified compromise solutions of (19)

λ	R_1	R_2	R_3	R_4	R_5	δ_{R_S}	$\delta_{C'_S}$	$R_S(R)$	$C'_S(R)$
0.9014520	0.9588488	0.9746650	0.8939865	0.8531018	0.9525368	0.205049	1479.071	0.206754	− 3964.032

Table 5 Second modified compromise solution of (19)

λ	R_1	R_2	R_3	R_4	R_5	δ_{R_S}	$\delta_{C'_S}$	$R_S(R)$	$C'_S(R)$
0.8669917	0.957028	0.973917	0.891028	0.8490947	0.950442	0.3001151	1493.541	0.605869	− 2469.679

Table 6 Comparison of solutions with different approaches (for $W_1 = W_2 = 0.5$ and $w = 0.9$)

	(1) Fuzzy multi-objective goal programming (FMOGP) approach	(2) Intuitionistic fuzzy approach (Mahapatra and Roy 2010)	(3) IWFGP approach
R_S	0.8657118	0.8056771	0.9596806
C'_S	-532.874	-511.962	-619.153
D_1	0.3684672	0.3557868	0.3710777
D_2	0.3997845	0.5649380	0.3739850
D_∞	0.4064596	0.4429461	0.3739738

direction during the solution procedure and as a result, the DM's preferences achieve efficient solutions. In this paper the proposed approach focuses on maximizing the worst lower bound to obtain the preferred compromise solution which is close to the best upper bound of each objective functions. Updating both the membership values and the aspiration levels during the solution procedure, it controls the search direction. Thus the proposed method is an efficient and modified optimization technique and gives a highly reliable system than the other existing methods. An illustrative numerical example was provided by comparing the result obtained in the interactive method with the other methods to demonstrate the efficiency of the proposed method.

Acknowledgements The authors wish to acknowledge to the editor and reviewers for their valuable comments in improvement of the quality of this manuscript. This support is gratefully acknowledged.

Open Access This article is distributed under the terms of the Creative Commons Attribution 4.0 International License (<http://creativecommons.org/licenses/by/4.0/>), which permits unrestricted use, distribution, and reproduction in any medium, provided you give appropriate credit to the original author(s) and the source, provide a link to the Creative Commons license, and indicate if changes were made.

Appendix

In the proposed interactive method there are some restrictions on modifying the membership functions of objectives and fuzzy constraints. Only the following variations are acceptable for modification:

1. Increase in L_r : Increase in L_r leads to the rise of requirement on the p th objective. All feasible solutions x with $f_r(x) < L_r(\text{new})$ are eliminated from the new feasible solution set. Now, we should increase as few requirements as possible in each iteration to avoid the possibility of getting into empty feasible solutions set because of excess increases of L_r . We must be very careful to modify U_r when the decision maker insists on changing U_r , because reduction of the upper bound U_r can lead to an inefficient solution.

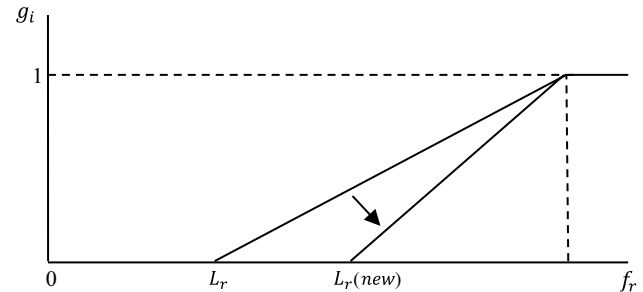

Fig. 4 The effects of changing L_r

2. For the constraints $\leq, \geq, =$, the decrease of p_i is an acceptable modification which can guarantee an efficient solution in the recalculated compromise solution step. The consequence of an increase of p_i with $\leq, \geq, =$ constraints might be, for example, that the feasible solution set increases and new possible solutions are included in the investigation (Fig. 4).

References

- Bellman RE, Zadeh LA (1970) Decision making in a fuzzy environment. *Manage Sci* 17(4):B141–B164
- Chen SH (1985) Ranking fuzzy numbers with maximizing set and minimizing set. *Fuzzy Sets Syst* 17:113–129
- Dancese M, Abbas F, Ghamry E (2014) Reliability and cost analysis of a series system model using fuzzy parametric geometric programming. *Int J Innov Sci Eng Technol* 1(8):18–23
- Dhingra AK (1992) Optimal apportionment of reliability and redundancy in series system under multiple objectives. *IEEE Trans Reliab* 41:576–582
- Gen M, Ida K (1993) Large-scale 0–1 fuzzy goal programming and its application to reliability optimization problem. *Comput Ind Eng* 24:539–549
- Grag H (2013) Fuzzy multi-objective reliability optimization problem of industrial system using particle swarm optimization. *J Ind Math*. Article id: 872450
- Hao P, Wang Y, Liu C, Wang B, Wu H (2017) A novel non-probabilistic reliability-based design optimization algorithm using enhanced chaos control method. *Comput Methods Appl Mech Eng* 318:572–593

- Hao P, Wang Y, Ma R, Liu H, Wang B, Li G (2019) A new reliability-based design optimization framework using iso-geometric analysis. *Comput Methods Appl Mech Eng* 345:476–501
- Hwang CL, Lee HB (2004) Non-linear integer goal programming applied to optimal system reliability. *IEEE Trans Reliab* 33:431–438
- Hwang CL, Lee HB (2009) Non-linear integer goal programming applied to optimal system reliability. *IEEE Trans Reliab* 33:431–438
- Kuo W, Prasad VR (2000) An annotated overview of system-reliability optimization. *IEEE Trans Reliab* 49(2):176–187
- Kuo W, Prasad VR, Tillman FA, Hwang C (2001) *Optimal reliability design—fundamentals and applications*. Cambridge University Press, Cambridge
- Leberling H (1981) On finding compromise solutions in multi criteria problems using the fuzzy min-operator. *Fuzzy Sets Syst* 6:105–118
- Liou TS, Wang MJJ (1992) Ranking fuzzy numbers with integral value. *Fuzzy Sets Syst* 50:247–255
- Mahapatra GS, Roy TK (2010) Intuitionistic fuzzy multi-objective mathematical programming on reliability optimization model. *Int J Fuzzy Syst* 12:259–266
- Misra KB (1971) A method of solving redundancy optimization problems. *IEEE Trans Reliab* 20:117–120
- Neubeck K (2004) *Practical reliability analysis*. Pearson Prentice Hall Publication, New Jersey, pp 21–22
- Park KS (1987) Fuzzy apportionment of system reliability. *IEEE Trans Reliab* 36:129–132
- Sakawa M (1978) Multiobjective reliability and redundancy optimization of a series-parallel system by the surrogate worth trade off methods. *Microelectron Reliab* 17:465–467
- Sakawa M, Matsui T (2012) An interactive satisficing method for multi-objective stochastic integer programming with simple resource. *Appl Math* 3:1245–1251
- Sinna MA, Abo-Elnaga YY (2014) An interactive dynamic approach based on hybrid swarm optimization for solving multi-objective programming problem with fuzzy parameters. *Appl Math Model* 38:2000–2014
- Steuer R (1986) *Multiple criteria optimization: theory, computation, and application*. Wiley, New York
- Wahed A, Lee S (2006) Interactive fuzzy goal programming for multi-objective transportation problems. *Int J Manag Sci* 34:158–166
- Wang C, Qiu Z, Xu M, Li Y (2017) Novel reliability-based optimization method for thermal structure with hybrid random, interval and fuzzy parameters. *Appl Math Model* 47:573–586
- Zadeh LA (1965) Fuzzy sets. *Inf Control* 8:338–353
- Zangiabadi M, Maleki HR (2007) Fuzzy goal programming for multi-objective transportation problem. *J Appl Math Comput* 24:449–460