

# A Simulation Model for Optimization of the Internal Handling Fleet Size at Shahid Rajaei Container Port Based on Performance Evaluation

Parham Azimi<sup>a,\*</sup>, Mohammad Reza Ghanbari<sup>b</sup>

<sup>a</sup> Assistant Professor, Faculty of Industrial and Mechanical Engineering, Qazvin Branch, Islamic Azad University, Qazvin, Iran

<sup>b</sup> MSc, Young Researches Club, Qazvin Branch, Islamic Azad University, Qazvin, Iran

Received 6 January, 2011; Revised 28 February, 2011; Accepted 23 March, 2011

---

## Abstract

The dramatic increasing of sea-freight container transportations and the developing trend for using containers in the multimodal handling systems through the sea, rail, road and land in the present market cause some challenges to the general managers of container terminals such as increasing demand, competitive situation, new investments and expansion of new activities and the need to use new methods to fulfil effective operations both along quayside and within the yard. Among these issues, minimizing the turnaround time of vessels is considered to be the first aim of every container port system. Regarding the complex structure of container ports, this paper presents a simulation model that calculates the number of trucks needed in Shahid Rajaei Container Port for handling containers between the berth and the yard. In this research, some important criteria such as vessel turnaround time, gantry crane utilization and truck utilization have been considered. By analyzing the results of the model, it will be shown that increasing the number of trucks to 66 units has a significant effect on the performance indices of the port and can increase the capacity of loading and unloading up to 10.8%.

*Keywords* : Container terminal; Simulation; Vessel turnaround time; Gantry crane utilization.

---

## 1. Introduction

Within the last two decades, container transportation system has increasingly developed so that the rate of this development has reached to 7 or 9 percent in a year (Vacca [15]) and it is predicted that this increase will approach 10 percent until 2020 (Henesey [6]) while for other sea transportation means, the rate will be just 2 percent annually. This fact reveals the importance of container transportation system as a key role of container terminals to link between sea and land. Although container terminals are increasing their capacity to respond to these increasing demands, the rapid increase in the transportation of containerized goods has created a continuous need for the optimal use of equipment and the facilities in the port so that the operational costs could be decreased and the performance of the ports could be improved.

Shahid Rajaei Container Port (SRCT) as the biggest container port in Iran is in the south of Iran in the entrance of the mouth of Persian Gulf, which trades goods

and it is currently connected to more than 80 well-known ports throughout the world. Terminals 1 and 2 with the storage capacity of 168,000 TEU (Twenty Equivalent Unit) are able to do 3,100,000 TEU container operations a year in this port. The performance of SRCT indicates its increasing development in container operations in recent years so that this development is noticeably observed in the reputable world ranking reports. The operation capacity has increased from 82,920 TEU to 237,174 TEU between 1993 and 1996 which shows the average increase of 42 percent in a year. This fact could promote its rank from 184 to 116. While according to the statistics published in the international journal of cargo system, the rank of Shahid Rajaei port with 1,723,000 TEU was 88 in 2008. It should be mentioned that the rank of this port is 66 among all ports in the world (Nazari [12]). On the other hand, according to the Iranian Commercial Ports Master Plan, Shahid Rajaei port, as the biggest port in Iran, must carry out 45 percent of total exchanged cargos among all ports.

---

\* Corresponding author E-mail : p.azimi@yahoo.com

Despite the construction of the expansion phases of the port regarding the expansion of container loading and unloading operations, resource management and efficient use of available equipment are among the concerns of the SRCT managers.

In general, there are three major problems that managers of container ports should consider: the type of subsystem available in the port, the kind of decision and the time period of decisions. Fig. 1 shows a classification of the current problems in ports (Rushton [13]).

These subsystems are as follows:

**Ship to shore:** It is a subsystem that is related to unloading a container from the ship to the berth and vice versa.

**Transfer:** in this subsystem, the containers are transferred from the berth to the storage area or vice versa.

**Storage:** includes all procedures related to storage and holding container systems in the existing blocks.

**Delivery / receipt:** This subsystem is a common intersection among internal, road and railroad systems and it is a place for delivering and receiving containers from the customers.

Fig. 2 depicts a picture of a container port with four subsystems.

In the next step, making a right decision is highly significant in handling common problems, and can affect the process of adopting the methods for solving problems. Problems related to planning mostly deal with designing and developing processes or can say that they are "Doing the right thing" (Rushton [13]), while controlling mostly deals with supervising activities; in other words "Doing the thing right".

After classifying problems within the framework of subsystems and determining the kind of decision, the solutions must be divided into three time periods: long-term or strategic, tactical and operational. As it was shown in Fig.1, the problems regarding the kind of planning are mostly considered as strategic and tactical periods while controlling problems just focus on short –term operations.

these researches have made some special assumptions to simplify the real-world problems (Shabayek [10]). For example , most researches just considered a single queue for internal operations while in a real port, there are several queue networks which increase the complexity of problems and decrease the power of analytical methods like queuing theory in solving such problems. Wen Chih Huang [2] mentioned the drawbacks of using analytical methods and considered simulation method as a suitable mean of solving problems in this field. Also, Won Young Yun [17] concluded that simulation method is an effective option for system analysis of container ports.

Simulation is not a new methodology for ports and it has been used since 1980 (Carteni [1]), but most studies have emphasized management operations rather than developing more details of the models. Also, the previous researches did not consider the validation processes for their models. On the other hand, many researchers have only restricted themselves to a simple view of information and/or probability density functions. For example, in many cases, they have replaced all stochastic parameters with exponential distribution (Carteni [1]).

Collier [4] was the first researcher who introduced simulation for port study. Following him, there were some activities about the use of simulation in different ports. Most works carried out in 1990s were focused on simulation of case studies, and terminal subsystems were studied and analyzed separately. In this period, there was less focus on creating models with more details. From 1990 to 2000, most works were focused on developing simulation technique for port operations. However, they did not consider the performance criteria in their studies. Towards the end of this decade, the use of statistical functions became common simulation inputs, such that distribution functions like exponential were used for the service time of transportation equipments while Weibull distribution was found to be more appropriate for gantry crane service times. However, a few recent researches considered validation process according to historical data.

Until 2000, most of the papers published about the operations and management of container ports focused on methods of optimizing the subsystems separately. For example Kim [9] studied optimizing the number gantries needed for the operation of unloading imported containers. But after 2000, the method of simulation as one of the methods of evaluation was divided into two groups. The first group focuses on one of the subsystem of the port (Yang [16]), while the second group makes a general models for all subsystems of the in order to create a certain degree of integration among logistic chains in the port (Itmi [7]). In this paper, attempts were made to use the second group to create a general model of the existing activities in SRCT from vessels arrival, berthing on the quay, unloading the container to storage and reloading of container on the vessels and provide in order to have an appropriate degree of integration for the examination of SRCT performance.

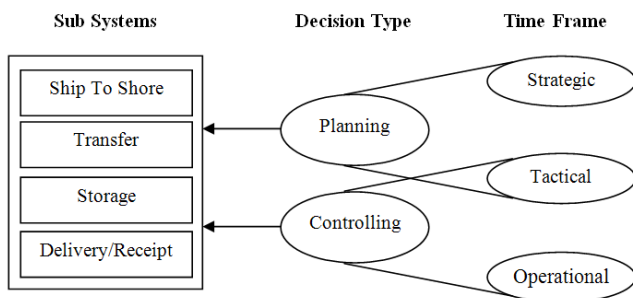

Fig. 1. Container Ports Problems Framework

In spite of the kind of classification, the methods of solving problems have also created certain varieties in previous researches on container ports. The bulk of studies have used queuing theory as a method for estimating the performance of the system, e.g. Kozan [10]. But most of

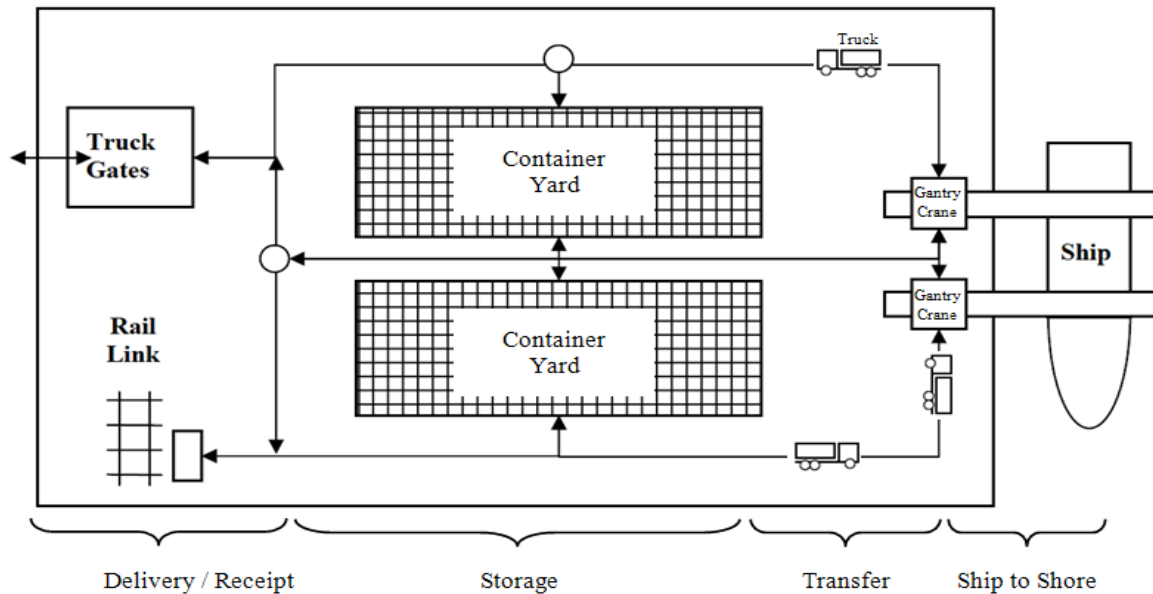

Fig. 2. Container Port Sub-systems

Therefore, in this paper, the mentioned port (SRCT) simulation method is used as the best substitution for queuing theory while time indices that are very important in queuing theory have been examined in a complicated real world environment. On the other hand, using the simulation software (Enterprise Dynamic) and the existence of its 3D graphic utilities besides its animation environment, caused to carry out a good verification process of the model. In the used model, there are 3 subsystems of ship to shore transfer and storage and covers a considerable integration of the container transportation chain in the port. Also, it provides the possibility to adapt the model with the reality for any kind of analysis. One of the other outstanding points in this paper is considering the detailed configuration of unloading, loading and transferring of containers equipment with stochastic repair and maintenance times for gantry crane which have not been studied in previous researches so far. This fact is very important because the failure rate of equipments is a key factor in determining the rate of resources utilization in any processes. The purpose of the current study is to create a model for SRCT in order to determine the number of trucks needed for handling unloaded containers from the vessels and transferring them to the container yard and also transferring containers from container yard to the berth to load the vessel. For this reason, some important performance indices such as the average stay of the vessel in the system (turnaround time) and utilization of gantry cranes and trucks have been used.

In section 2, there is a description of the problem. In section 3, the process of modeling along with input data in the model, warm-up period and validation are explained. In section 4, the simulation output is examined to determine the number of trucks needed in SRCT and finally in section

5, the summary of the results and future opportunities are explained.

## 2. Description of the Problem

A container terminal (CT) is a place where ships can be berthed near the quay and can give some services by gantry cranes (GC). The given services include unloading the container from the vessel or loading the container on the vessel. A container terminal usually makes the connection between the sea and the land possible. Also, container terminals can be viewed as a temporary storage areas; so the containers can be kept there from the time of unloading till the moment of being delivered to the customers. Technically, the time period between the entrance of the container to the port and the time when it is delivered to the customers is called Dwell time. Therefore, the unloaded container from the vessels by GC should be transferred to suitable determined places in the yard. To do so, the containers in SRCT are loaded on some internal trucks after unloading in order to be transferred to the container yard (CY). With respect to the fact that the unloaded container is an import (IM), a refrigerator (RF), a transship (TR) or empty (EM), it should be moved to the related blocks determined in the CY. As soon as the trucks arrives to the CY, other equipments called Rubber Tyred Gantry Crane (RTGC) start unloading trucks and arrange the containers in predetermined blocks. As mentioned before, a container may be kept in the CY from one hour to several days, and then it is taken away from the CY either to be loaded on the vessel or to be delivered to the customers. TR containers are the ones which are usually unloaded from bigger ships in the terminal and for reloading on ships that depart toward other container terminals in or out of country. They

are temporarily kept in the port. These kinds of containers together with EX containers -which are in the related blocks in the CY-, are being used to load on vessels by RTGCs. The period when a vessel spends in container ports (turnaround time), is the most important performance factor of the port. This time starts from the moment that the vessel enters the port and included the waiting time for berthing, the time needed to moor the vessel and the time for giving services to the vessel (loading and unloading). It ends when the vessel leaves the quay. Lengthening the turnaround time can be costly for the owners of container ports; therefore, decreasing this index to the lowest possible amount is among the first goals of container port systems. In this regard, employing appropriate regulations for handling of containers in the port and optimal use of equipments and resources can contribute to decreasing this time period. As pointed out in a lot of studies, the relationship between the berth and CY is the most important factor in planning process of ports (Henesey (2006)).

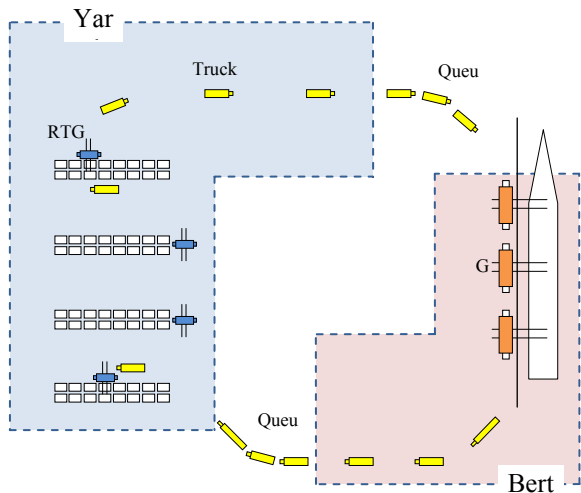

Fig. 3. The movement of trucks between berth and CY in a closed loop system

The case starts when a specified number of trucks travel a specific route between the berth and CY to carry the containers. Usually, every truck carries one container. A delay in the departure time of the trucks occurs when they wait in queue in the berth or in the yard to load or unload containers. The length of queue or the waiting time for the trucks depends on variety of factors including the number of trucks available, GCs and RTGs. Fig.3 depicts the route of a container from the berth to CY and vice versa (Kang [8]).

In the present paper, the aim is to determine the appropriate number of trucks with respect to three indices of turnaround time, GC and truck utilizations and examine the effect of the changes in the number of trucks on improving the performance of the port.

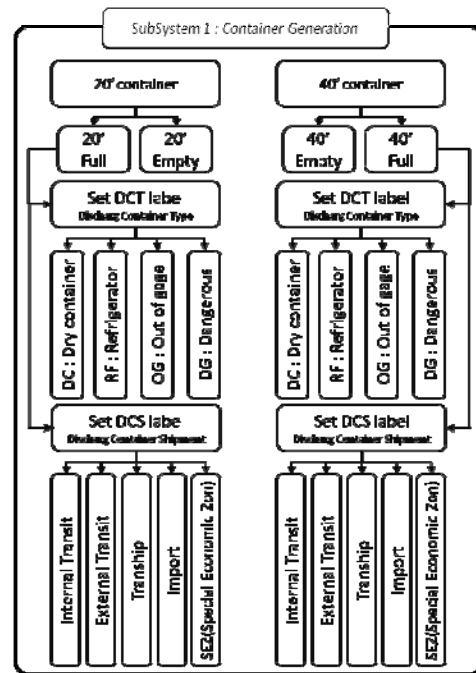

Fig. 4. Sub System 1: Container Generation

### 3. Simulation Model

In this section, the details of port model are provided. First, the structure of the model is described and then the inputs of the model are presented. The warm-up period and the accuracy of the model are also presented in this section.

#### 3.1. Model Architecture

The structure of the model is made up three subsystems which provide entrance resources to the main framework of the model. The structure of these three subsystems and main framework of the model are explained as follows.

##### 3.1.1. Subsystem 1: Container Generation

The containers that a vessel carries to SRCT can have some characteristics. In term of size, it can be 20 or 40 feet; the type of containers can be categorized as Dry containers (DC), refrigerator containers (RF), out of gage containers (OG), and dangerous containers (DG); the type of transportation can be categorized as Internal transit, external transit, import, export, transship and SEZ. In this subsystem with respect to the gathered data about these three characteristics, the containers are generated and given a label according to their characteristics, in the simulation model. Fig.4 depicts the subsystem for generating the containers.

3.1.2. Subsystem 2: Vessel Arrival

In this subsystem, the vessels enter to the port with the average of 9.41 hours as inter arrival time with exponential distribution. At the time of arrival, we set the LOA label on each vessel. This label shows the length of the vessel. We generate it according to the historical data. After that, we determine the number of containers that each vessel should load and unload in the port by two labels. Fig .5 shows this subsystem.

3.1.3. Subsystem 3: Checking Entrance Condition

After assembling containers on the vessel, the vessel enters the anchorage and will wait to enter the berth, with respect to the length of the vessel (LOA). There is a constraint that the total length of vessels in the anchorage must not exceed 1000 meters (the length of the berth), this is the entrance condition of the model. When this condition meets, the vessel is allowed to enter the berth, otherwise the vessel must wait. Fig .6 shows this subsystem.

3.1.4. Main Structure

Fig. 7 shows the structure of the model including: the method of loading and unloading of a vessel, the equipment used for this purpose, the movement of containers from the berth to the yard and vice versa and the method of storing in the yard. Regarding the fact that the delivery / receipt section is not included in the current study, the scope of study has been limited to the entrance and leaving of the containers toward the customer and the other details are neglected. As shown in this figure, containers are being unloaded in the berth based on the shipment label and RF, are stored in the related blocks and will remain in the yard till the time it leaves the terminal. Also, export containers or empty containers that are transported for loading, will remain for loading on the vessel after being placed in the defined blocks.

3.2. Data Collection

The data needed for creating the model was collected and analyzed through recorded documents available in SRCT in 2009. In this regard, we collected data from 935 arrived vessels into SRCT including: the arrival times, berthing times, operation times, the number of loaded and unloaded containers, the length of vessels and departure times from the port. The rest of information is about the equipment and the yard. To obtain the most appropriate distribution functions and carry out the statistical analysis, the data is examined by Easy Fit software.

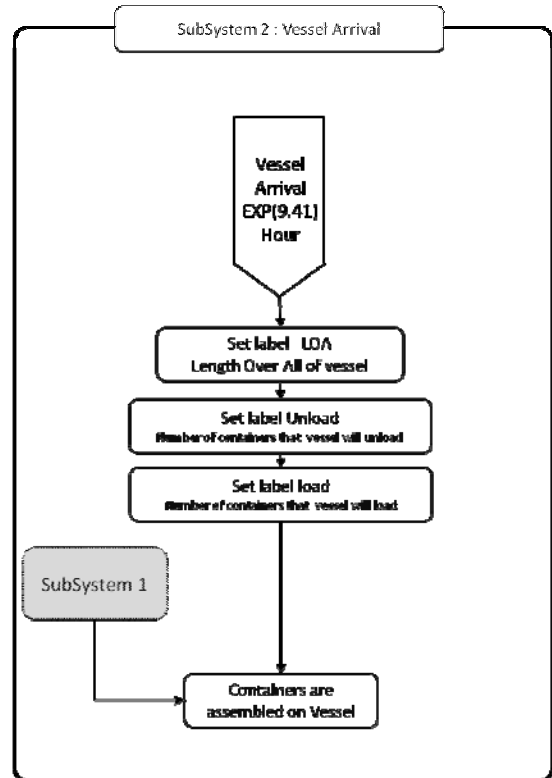

Fig. 5. Sub System 3: Check entrance condition

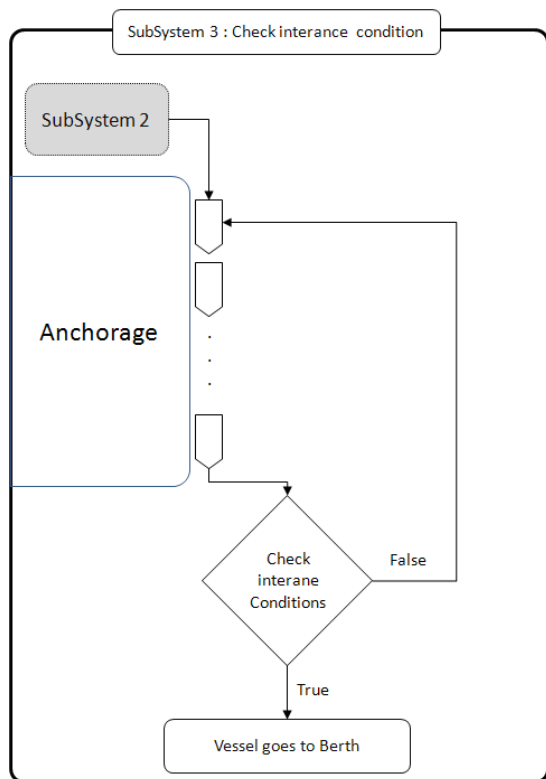

Fig. 6. Sub System 2: Vessel arrival

3.2.1. Container Generation Data

Considering the records related to vessels arrived in the port in 2009, 428,315 containers box were unloaded with the rate of 52% as 20 feet containers and 48% as 40 feet containers. Also, 8% of 20 feet containers and 5% of 40 feet containers were empty and the rest were full. To separate refrigerator containers from the other containers which require special conditions for keeping in the yard, the label about the kind of container is set on the containers with respect to Table 1. Also; Table 2 represents the share of the each container in shipment processes.

3.2.2. Vessel Data

Analyzing the arrival time of 935 vessels to the port and using the chi-squared test, we found out that the period of time between the arrival of two consecutive vessels has an exponential distribution with the average of 9.41 hours (Fig.8)

One of the features of a vessel is its length. Using the available data, we divided the length of the vessels into 15 spans. The results of the analysis are listed in Table 3. Each vessel carries a number of containers to the port for unloading, and each vessel loads a specific number of containers and leaves the port. The number of the containers is chosen according to an empirical distribution taken from the historical data.

Table 1  
Discharge Container Type

Type	Share (%)	
	40 ft. Container	20 ft. Container
DC	91.33	92.45
RF	7.42	0.46
OG	0.60	0.25
DG	0.65	6.83

Table 2  
Discharge Container Shipment

Shipment	Share (%)	
	40 ft. Container	20 ft. Container
internal transit	6.61	4.15
external transit	31.09	8.66
tranship	13.10	16.81
import	40.22	56.21
SEZ	8.99	14.16

Table 3  
Vessels LOA (meter)

class	Share	Average	class	Share	Average
50-100	4.81%	86	191-205	3.42%	200
101-120	2.99%	111	206-215	9.73%	209
121-140	2.25%	123	216-225	10.59%	220
141-150	12.62%	148	226-240	5.35%	237
151-160	9.63%	156	241-260	9.63%	251
161-170	9.30%	169	261-280	5.13%	270
171-180	5.99%	177	281-...	3.21%	297
181-190	5.35%	185			

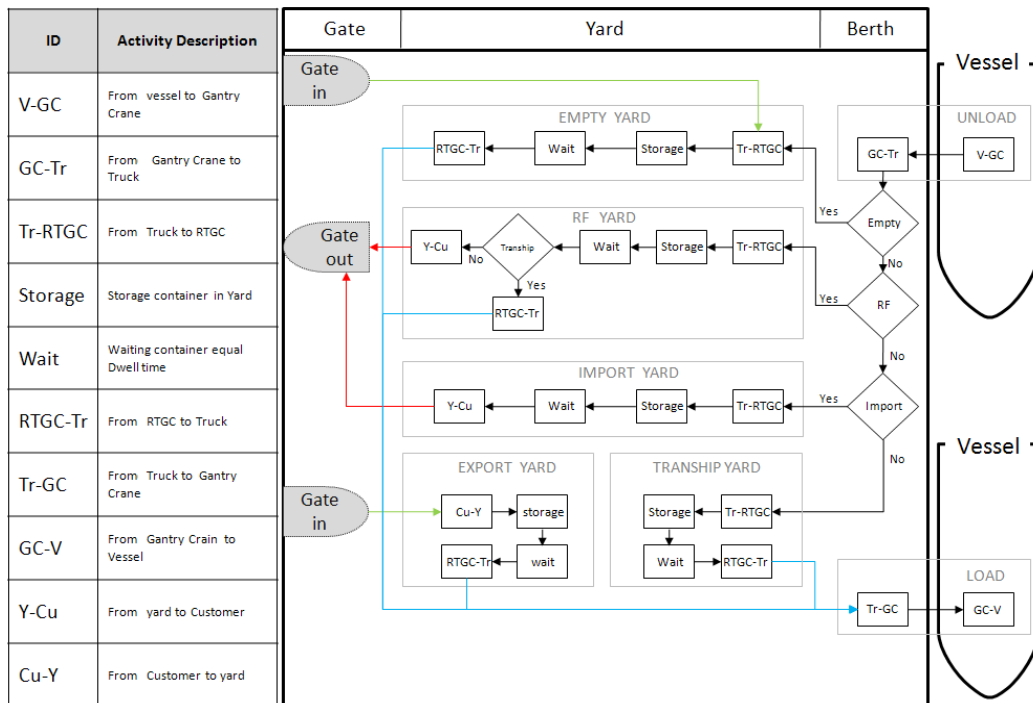

Fig. 7. Model ain structure



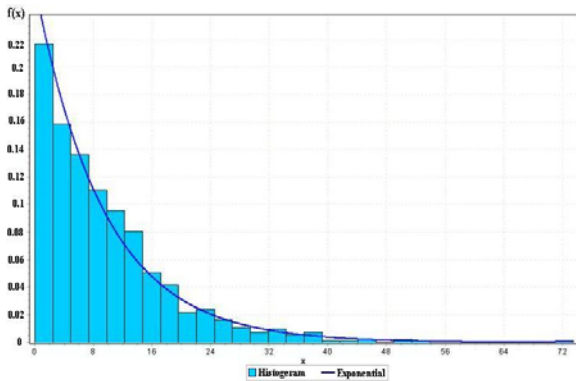

Fig .8. probability density function of vessel inter arrival time

### 3.2.3. Equipment Attribute

#### 3.2.3.1. GC Service Time

Based on the standard system used in SRCT, each GC should carry out 25 moves/ hour which are equal to 144 seconds for every move. But, according to the data gathered in actual operations, the number of movements follows the normal distribution with the average of 21 moves/ hour and the standard deviation of 5.56. On the other hand, the service times have lognormal (180.83, 49.86) distribution in the real world which was used in the simulation model.

#### 3.2.3.2. GC Failure

With the analysis of the 10 gantry cranes available in SRCT, and supposing that the mean time before repair (MTBR) is equal to zero, and also supposing that the mean time to repair (MTTR) for each GC follows the empirical distribution, the related index of MTTF for all GCs follows Weibull distribution and its parameters are listed in Table 4 in term of minutes.

Table 4  
Gantry Crane MTTF(Mean Time To Failure)

GC	Weibull( $\alpha, \beta$ )		GC	Weibull( $\alpha, \beta$ )	
	$\alpha$	$\beta$		$\alpha$	$\beta$
1	0.84	1219	6	0.88	1030
2	0.84	1439	7	0.91	1060
3	0.83	1294	8	1	1026
4	0.87	1309	9	0.93	963
5	0.92	1747	10	0.96	1100

#### 3.2.3.3. RTGC service time

The technical specifications of RTGCs are given in Table 5. According to the gathered information, the service time for every loading and unloading is equal to normal distribution with the average of 84.52 seconds and the standard deviation is 18.92. The number of RTGCs

determined for the model is 41 cranes. Each block in Figure 9, has one dedicated RTGC.

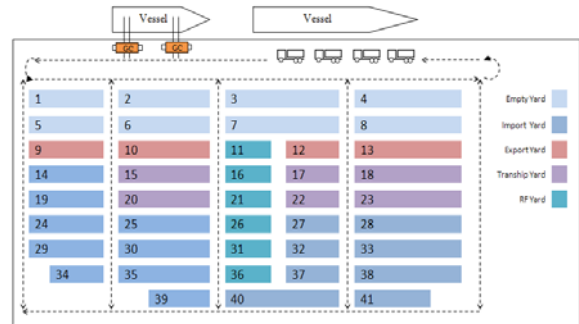

Fig. 9. SRCT Yard Layout

Table 5  
RTGC specifications

Speed	
Hoist speed Empty	40 m/min
Hoist speed Loaded	20 m/min
Trolley speed	70 m/min
Gantry speed	130 m/min
Wheel Span	
6+vehicle lane	23.47 m
Stacking / lifting height	
1 over 4	15.24 m

#### 3.2.3.4. Truck

At the time of the present study, 50 trucks are handling the containers between the berth and the yard in the port area. The highest speed for the movement of the trucks in the port area is 25 Km/h.

#### 3.2.4.4. Yard layout

In Fig.9, some specific blocks for container storage in the yard are shown. The yard has the holding capacity of 30,000 TEU. Also, the routes of the truck, including one-way or two-way routes can be observed. We have used an empirical distribution for Dwell times.

### 3.2.5. Assumptions of the Model

Attempts were made to avoid any simplifying assumptions in constructing the model, except for the following four items which do not have any important effects on the results:

#### 1-The strategy for selecting trucks for loading:

There are N trucks in the model, the first waiting truck is called for loading, if the first truck is receiving service, the model calls for the second truck and so on up to the last truck and if there is not any empty truck for loading, this cycle is restarted.

#### 2-Usually a specific number of trucks are devoted to each GC for loading and unloading operations, but in the model, it was supposed that all the trucks can give services to all GCs. This will cause an increased rate of trucks utilization.

- 3-It is supposed that there is no traffic in the route of the trucks.
- 4-For loading the vessels, the containers with better dwell times have priority.

3.3. Warm up Period

In the beginning of the simulation, the model is empty without any inventory. Therefore, the data obtained from may not be appropriate for analysis. To avoid this matter, a period of time is taken into account for the model as the warm-up period. This is the passing time for the system to move from a state of instability to a relative stability. There is variety of methods for determining this warm-up period. In this study, we have used the Welch method (Law [11]). This method is based on the repetition in the different time periods of simulation and drawing the graphic diagram for the moving average of the index. The index used here is the number of unearthed ships. According to the results, the value of this index is between 1 to 35-week periods and for each period ten different replications were done in the simulation model. Finally, by drawing the graphic diagram of the moving averages, it was shown that after week 13, the model has a stable behaviour. Therefore, in the analysis of the model, 13 weeks is considered as the warm-up period as illustrated in Fig.10 below.

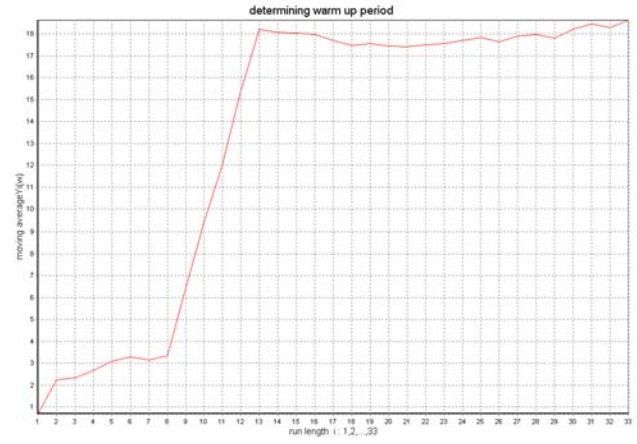

Fig. 10. Determining the Warm Up Period

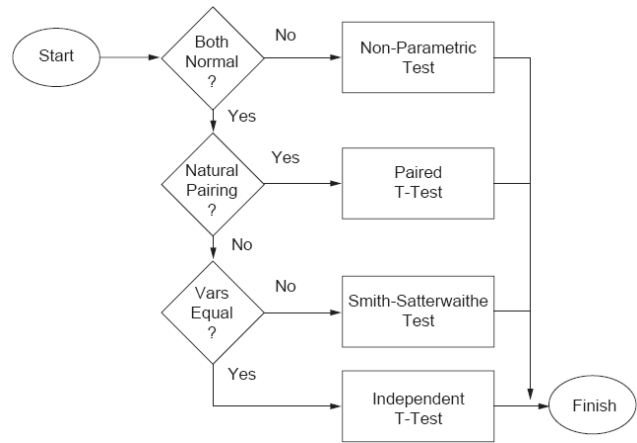

Fig. 11. Validation procedure

3.4. Verification and Validation of the Model

Regarding the fact that the presented model has been constructed in a graphical environment, and the simulation software has several tools for creating animation and 3D environments, the model enjoys adequate accuracy in terms of verification.

Also, validation which is required as a process for achieving certainty of the performance of the model in an acceptance level was conducted using a statistical Procedure. In this section, the model validation data set and the actual system validation data set will be compared. The diagram in Fig.11 presents the stages of validation process (Chris [3]).

The criterion determined for the comparison of the real system with the model is the performance of loading and unloading of a unit which is obtained through dividing the number of unloaded and loaded containers on the ship by the time of operations performed on the ship (container in an hour).

The first step is to clarify whether two sets of data have normal distribution or not. To this end, the chi-squared test was used. Regarding the results, Table 6, 7 show that both sets have normal distributions.

Table 6

Actual system					
Ho: System validation data set is normally distributed					
Ha: System validation data set isn't normally distributed					
Deg. Of freedom	9				
Statistic	7.8745				
P-Value	0.54684				
A	0.2	0.1	0.05	0.02	0.01
Critical Value	12.242	14.684	16.919	19.679	21.666
Reject?	No	No	No	No	No

Table 7

Actual system					
Ho: Model validation data set is normally distributed					
Ha: Model validation data set isn't normally distributed					
Deg. Of freedom	9				
Statistic	9.8846				
P-Value	0.35991				
A	0.2	0.1	0.05	0.02	0.01
Critical Value	12.242	14.684	16.919	19.679	21.666
Reject?	No	No	No	No	No

Considering the fact that the nature of data is not in pairs, the F-test was used to determine whether the variances of two sets of data are similar or not. The hypothesis test and its results are as follows:

**Ho:** The variance of the system validation data set is equal to the variance of the model validation data set.

**Ha:** Otherwise.



Also, the significance level is 0.95.

**Results:** The test statistic (1.055) is less than the critical value (1.114); so the null hypothesis cannot be rejected. (see Table 8)

Table 8  
F-Test Two-Sample for Variances

	Model validation data set	System validation data set
Mean	49.41356742	50.44158289
Variance	438.5440335	415.8711457
Observations	930	935
df	929	934
F	1.054519021	
P(F<=f) one-tail	0.208999894	
F Critical one-tail	1.113861981	

In the next step, the independent t-test was utilized. The independent t-test is used when the data are normal and the data sets have similar variances. This test determines if there is a statistically significant difference between two simulation models at a given level of significance.

In order to perform this test, the mean and sample standard deviations of both data sets were calculated. Table 9 shows the mean and the sample standard deviation of data sets and Table 10 depicts the results of T-test.

Table 9  
mean and sample standard deviation of data sets

Actual system	Model
Mean 50.442	Mean 49.413
Standard deviation 20.393	Standard deviation 20.941

**H<sub>0</sub>:** means of the system validation data set and the model validation data set are equal.

**H<sub>a</sub>:** Otherwise.

Again the significance level is 0.95.

**Result:** The test statistic t (1.074) is between -1.961 and 1.961; so the null hypothesis cannot be rejected.

Table 10  
t-Test: Two-Sample have Equal Variances

	System validation data set	Model validation data set
Mean	50.44158289	49.41356742
Variance	415.8711457	438.5440335
Observations	935	930
Pooled Variance	427.1771643	
Hypothesized Mean Difference	0	
df	1863	
t Stat	1.073998063	
P(T<=t) one-tail	0.141481317	
t Critical one-tail	1.645671948	
P(T<=t) two-tail	0.282962634	
t Critical two-tail	1.961238109	

#### 4. Experimental Results

In this section, we present several experiments designed in the simulation model in order to minimize the number of trucks needed for the transportation operation between the

berth and the yard. In this regard, we considered two important indices in the port with satisfying the mentioned limits. The experiments were carried out with the following characteristics:

- The decision variable is the trucks available in the port area which was 50 trucks in the study period. In the experiments, this number was changed from 30 to 70 trucks.
- The Indices used are: GC utilization and vessel turnaround time
- The observation period is determined to be one year.
- The number of observations or the number of replications is 5.
- The warm-up period is 13 weeks.

##### 4.1. GC Utilization

In order to calculate the utilization of ten available GCs, four different cases are defined as follows:

**Busy time (utilization):** when the GC is busy for loading or unloading.

**Waiting time:** when the GC is waiting for the truck for unloading.

**Down time:** when the GC is out of service.

**Idle time:** when there is no demand for the GC and none of the 3 previous cases happened.

The trend of changes in term of the average of each case against different numbers of the decision variable is presented in Table 11.

Table 11  
GC status percentage

Truck	Busy time	Waiting time	Down time	Idle time
30	35.70	16.51	3.25	44.53
32	37.21	13.79	3.76	45.24
34	38.44	11.71	3.91	45.95
36	39.63	10.22	2.82	47.34
38	40.98	8.82	3.73	46.48
40	42.90	6.58	3.69	46.83
42	43.68	5.58	3.41	47.33
44	44.18	4.93	3.48	47.40
46	45.00	4.15	2.97	47.88
48	45.65	3.36	3.07	47.91
50	46.21	2.86	3.37	47.56
52	46.83	2.40	3.64	47.13
54	47.56	1.92	3.13	47.39
56	48.83	1.63	3.68	45.85
58	49.61	1.11	3.78	45.51
60	50.52	0.65	3.40	45.43
62	51.27	0.23	2.74	45.76
64	51.30	0.20	3.75	44.74
66	51.30	0.19	3.16	45.35
68	51.31	0.20	3.44	45.05
70	51.30	0.22	3.41	45.08

As Fig. 12 illustrates, by increasing the number of trucks in the port, the waiting times for the GCs decrease and the busy times increase to the extent that any increase in the number of trucks will have no effect on this trend. To analyze this fact, it must be noticed that when the number

of trucks increases, the GCs will wait less for the arrival of trucks and this is the same as the fact that more times are for available GCs to load and unload and; therefore, the percentage of busy times for GCs will increase. With respect to the diagram of Fig.12 and Table 11, when the number of the trucks is more than 64, the busy time will be at the highest possible value and the waiting time will be the lowest. Because there are 50 operating trucks in the model and the percentage of the utilization of the GCs is equal to 46.21% and assuming that any change in the number of trucks increases this percentage; therefore, percentages lower than 46.21% cannot be considered as acceptable solutions. Unacceptable percentages are shown in grey in Table 11.

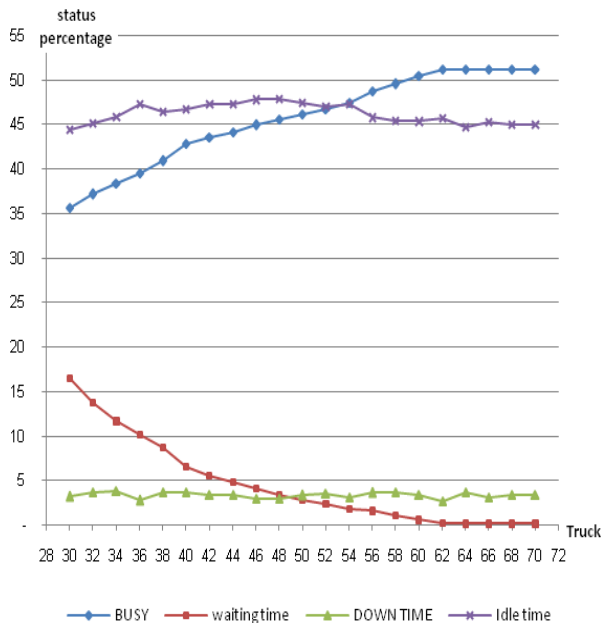

Fig. 12. Trend of GC 's status against unnumber of Trucks

#### 4.2. Vessel Turnaround Time

As pointed out earlier, this is the first and the most important index under consideration by the managers of all container ports. This fact has also been taken into consideration in Iranian Commercial Ports Master Plan so that the amount of this index must reach 24 hours for each ship until 2015. In the present study, given the available facilities and systems in SRCT, the turnaround time of each ship is equal to 32 hours. In this paper, it was tried to show that once adequate planning in using the resources is implemented, the handling operations between the berth and the yard could have considerable effects on decreasing this time. Table 12 and Fig. 13 show the results of experiments designed for examining the effect of the trucks versus the vessel turnaround time. When the ship is in the system, it has two specific times: the ship waiting time for receiving services and the time when the ship is in the berth (berth time).

As the results show, increasing the number of trucks in the port will result in decreasing the time ships in the

Table 12  
Vessel's turnaround time

Truck	Mean Berth time per vessel (hour)	Mean waiting time per vessel (hour)	Turnaround time (hour)
30	35.44	11.80	47.24
32	32.37	11.36	43.73
34	29.56	11.72	41.28
36	27.31	11.79	39.09
38	25.19	11.75	36.94
40	24.34	11.68	36.02
42	22.99	12.08	35.07
44	22.14	11.67	33.81
46	21.06	12.16	33.22
48	20.50	11.36	31.86
50	19.82	12.08	31.90
52	19.36	11.72	31.08
54	18.66	11.51	30.17
56	18.34	11.66	30.00
58	17.85	12.13	29.98
60	17.53	11.51	29.04
62	17.18	11.61	28.79
64	16.97	11.29	28.26
66	16.95	11.25	28.20
68	16.91	11.26	28.18
70	16.92	11.28	28.20

system. The reason is the GCs utilization already discussed in the previous section. If the GCs are considered as servers for vessels, and vessels are considered as customers, then by increasing the rate of utilization and decreasing the waiting times, the customers can carry out their tasks (i.e.

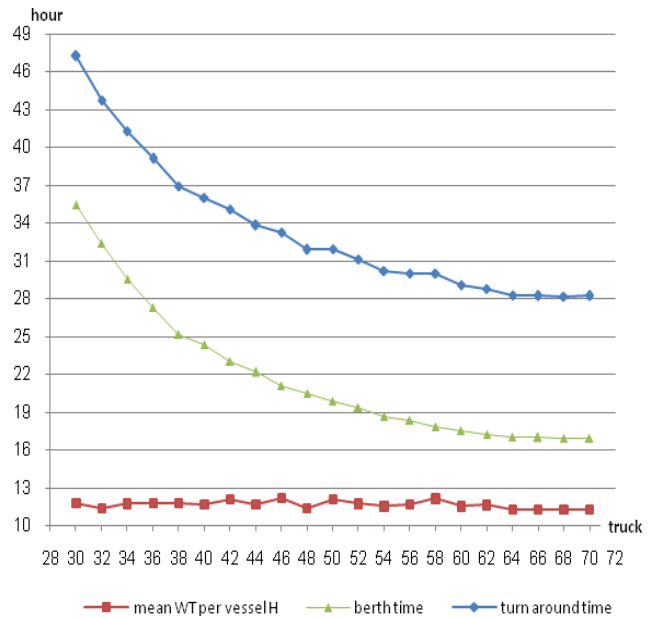

Fig. 13. Vessel's turnaround time

loading and unloading) faster and the time spent in the system decreases. Increasing the GCs utilization and decreasing their waiting times have direct effects on the number of trucks. This was verified in the current study. In other words, increasing the number of trucks leads to the increase of the busy time of GCs and any increase in the

busy times leads to a decrease in the service time to the ships and, consequently, in decreasing the turnaround time. Of course, if this trend continues and the number of trucks increases, then the waiting time for GCs approaches to zero and their busy time will reach a fixed amount and, therefore, there will be no decrease in the turnaround time. By observing the diagram in Fig.13 and Table 12, when the number of trucks is equal to 66, the time when ships are in the system will approach a fixed amount. This amount is 28 hours on the average for each ship in the port; which is still a little bit far from the goal of 2015(25 hours). As a result, decreasing the turnaround time for just 4 hours, it will increase more than 87,000 loading and unloading operations which are equal to an increase of about 11 % in the current capacity in SRCT.

Because this index is equal to 32 hours and it is expected that increasing the number of trucks will improve this index, the lowest possible value for trucks (48) was chosen in Table 12. The unacceptable region for the decision variable in the Table 12 is shown in grey.

#### 4.3. Minimum Number of Trucks

According to the results presented in the last two sections, the lowest values of the decision variable (48 and 50 trucks) were chosen to have at least 46.21% as utilization of GCs and the turnaround time will be less than 32 hours, respectively. Thus, the feasible region of the problem which is obtained from the integration of these two constraints shows that the number of trucks must be greater than 50 units. Since the ultimate goal is to maximize the utilization of the GCs and to minimize the turnaround time, increasing the number of trucks can help. However, this increase must not change the amount of these two indexes. According to what was mentioned before, the number of 64 or 66 trucks are the best solutions for minimizing the number of trucks needed for the transportation of containers between the berth and yard. This number of trucks can improve the amount of utilization of the GCs by 11% and the turnaround time by 12%.

On the other hand, assuming that the average time between arrivals of two ships is 9.41 hours, 930 ships will arrive in the port every year and each ship will face a decrease in the turnaround time equal to 3.8 hours. Therefore, a time capacity equal to 3,500 hours in a year will be added to the available capacity of GCs in the port and supposing 25 moves/hour for GCs, 87,000 moves will be added to the port capacity annually, which is 10.8% of the current capacity.

#### 4.4. Truck Utilization

After determining the number of required trucks in SRCT, in this section, we analyze performance and utilization rate of trucks in order to show that the number of trucks specified in this study meets the specified standards in term of the utilization rate of trucks in a container port. This standard assumes that the rate must be greater than 40 % [5].

In the analysis, the utilization rate of trucks is examined by considering different cases. These cases can be one of the following ones:

- S1:** waiting time in the queue before GC
- S2:** waiting time for loading / unloading by GC
- S3:** full moving time
- S4:** waiting time on queue before RTGC
- S5:** waiting time for loading / unloading by RTGC
- S6:** empty moving time
- S7:** Idle time

Considering the cases mentioned above, the utilization rate of a truck is defined as:

$$\text{Truck utilization index} = \frac{S2+S3+S5+S6}{\text{Total available time for truck}} = \frac{S2+S3+S5+S6}{S1+S2+S3+S4+S5+S6+S7}$$

Table 13  
Truck status percentage

Truck	S1	S2	S4	S5	S3+S6	S7	utilization
30	0	9.10	0	11.08	38.44	41.37	58.63
32	0	8.90	0	11.37	37.55	42.18	57.82
34	0.50	8.65	0	10.53	36.51	43.81	55.69
36	1.00	8.42	0	10.25	36.21	44.11	54.89
38	1.60	8.97	0	10.04	34.83	44.56	53.84
40	2.03	8.21	0	9.99	34.64	45.14	52.83
42	2.96	7.96	0.06	9.69	33.59	45.75	51.23
44	4.00	7.68	0.04	9.35	32.43	46.49	49.47
46	6.10	7.58	1.20	9.50	31.59	44.02	48.68
48	6.90	7.28	1.24	8.86	30.40	45.33	46.53
50	8.12	7.07	1.47	8.89	29.85	44.60	45.81
52	8.20	6.89	1.32	8.39	29.09	46.11	44.37
54	8.40	6.74	1.27	8.20	28.45	46.94	43.39
56	9.30	6.67	1.10	8.12	28.17	46.64	42.96
58	10.30	6.54	1.45	7.97	27.62	46.12	42.13
60	12.03	6.44	1.63	7.65	26.89	45.37	40.97
62	12.98	6.47	1.67	7.70	26.77	44.41	40.94
64	13.60	6.85	1.72	7.81	25.92	44.10	40.58
66	14.30	6.57	1.68	7.70	25.96	43.79	40.23
68	14.60	6.55	2.13	7.78	25.70	43.24	40.03
70	15.12	6.44	2.06	7.56	25.08	43.75	39.07

The results of the experiments are summarized in Table 13 and the diagram in Fig.14.

In the analysis of the S1, it can be assumed that trucks are customers that want to receive services from gantries; when the customers of a server are increasing and the rate of the service times of gantries remains constant, there will be an increase in the length of the queue followed by an increase in the waiting time. This fact is also true for S4 but because there are 41 servers (RTGC) in S4 case, the increase in waiting times in the queue of trucks has fewer slopes.

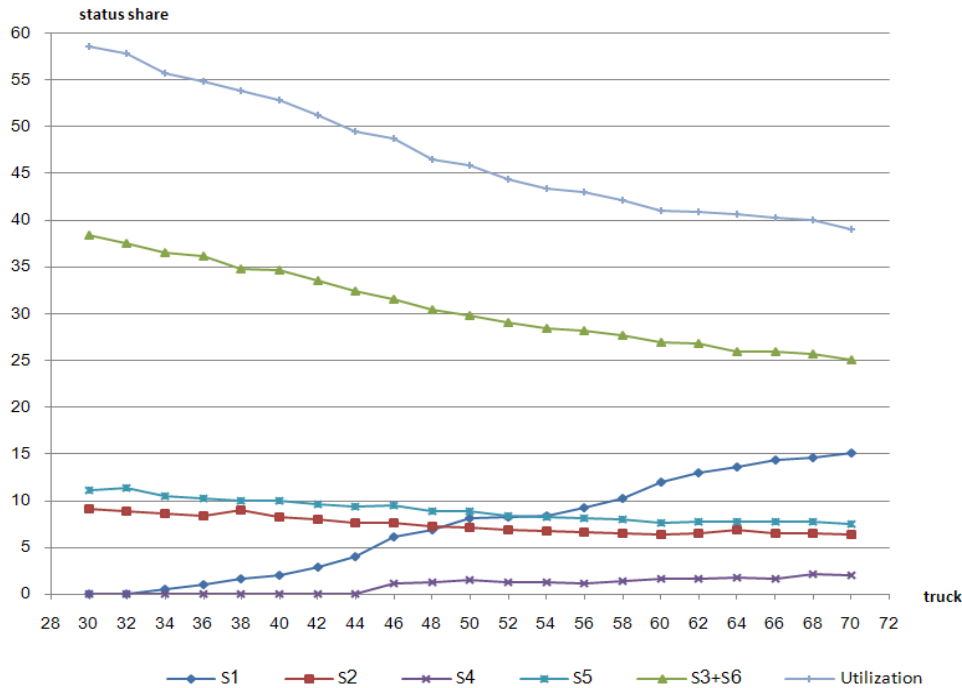

Fig. 14. Truck's status

In so far as the results for all cases are some proportions of the time spent for that case over the whole time available for all trucks and these rates are represented in percentages, it can be pointed out that any increase in the number of trucks leads to the increase of the denominator of the proportion calculated. Likewise, when the time of receiving service by trucks under GCs and RTGCs is constant, the rates related to S2 and S3 will face a little decrease, but generally these two cases will have constant trends.

To analyze S3 and S6 cases, suppose the trucks as servers for customers which are containers. When the rate of arrival and departure of containers or customers has a constant and specific trend, any increase in the number of servers will lead to a decrease of the utilization rate of trucks and, finally, the utilization rate of trucks – as presented in the diagram of Fig.14 – will decrease.

The results confirm that the values of 64 to 66 trucks meet the needed standard for trucks and are in accordance with the results obtained in the previous sections.

### 5. Conclusions and Suggestions for Future Research

In this paper, a model of all operations in SRCT was presented based on integration of subsystems and considering detailed specifications of transferring equipments. Our analysis of the results of the model revealed that increasing the number of trucks to 66 units has a significant effect on the performance indices of the port and can increase the capacity of loading and unloading up to 10.8%. Further, the designed model enabled us to perform evaluation of the system under conditions that the

port faces an increase in demands. As for upcoming directions of research, it is recommended to expand the scope of study from three subsystems into the whole system of container port which includes the detailed specifications of exit gates and doors. Also, it is recommended to verify the model from the cost viewpoint.

**Acknowledgments:** The authors would like to thank SRCT and Tidewater members for directing the project team and providing insightful comments.

### 6. References

- [1] A. Carteni, G. E. Cantarella, G. E. De Luca, Simulation of a container terminal through a discrete event approach: literature review and guidelines for application, Technical Paper, Dept. of Civil Engineering, University Of Salerno, 2009.
- [2] W. C. Huang, T. C. Kuo, S. C. Wu. A comparison of Analytical methods and simulation for container terminal planning. Journal of the Chinese Institute Of Industrial Engineers, 24(3), 200- 209, 2007.
- [3] C. Chung, Simulation modelling hand book: A Practical Approach, ISBN 0-8493-1241-8, Alk, 2000.
- [4] P. I. Collier, Simulation As An Aid To The Study Of A Port As A System. Ship Operation Automation III, 51-6, 1980.
- [5] P. Gouridis, C. Angelides, Simulation- bases Analysis of handling inbound containers in a terminal. Proceedings of The Winter Simulation Conference, 2002.
- [6] L. Henesey, P. Davidsson, J. A. Persson, Agent Based Simulation Architecture For Evaluating Operational Policies In Transshipping Containers. Multi agent System Technologies, LNAI, 4196, Springer, 73-85, 2006.

- [7] M. Itmi, M. Maria, A. B. Ndiaye, J. P. Ras, Simulating Operations Policies in a Container Terminal. Summer Computer Simulation Conference, 1-5; Cs.Org, 2001.
- [8] S. Kang, C. Medina, Y. Ouyang, Optimal Operations Of Transportation Fleet For Unloading Activities At Container Ports. Transportation Research Part B, 42, 970-984, 2001.
- [9] H. B. Kim, K. H. Kim, The Optimal Determination Of The Space Requirement And The Number Of Transfer Cranes For Import Containers. Computers And Industrial Engineering 35, Nos. 3-4 , 427-430, Elsevier, 1998.
- [10] E. Kozan, Comparison of Analytical and Simulation Planning Models of Seaport Container Terminals. Transportation Planning and Technology, 20 (3), 235 – 248, 1997.
- [11] A. M. Law, W. D. Kelton, Simulation Modelling and Analysis, 3rd Ed., New York: Mcgraw Hill, 2000.
- [12] D. Nazari, Hundred Container Ports in the Word. Port and Sea, 97-98, 2003.
- [13] A. Rushton, J. Oxley, The Handbook of Logistics and Distribution Management, Glasgow, UK, Bell & Bain Ltd, 2001.
- [14] A. A. Shabayek, W. W. Yeung, Simulation Model For The Kwai Chung Container Terminals In Hong Kong. European Journal of Operational Research, 140, 1-11, 2002.
- [15] I. Vacca, M. Bierlaire, M. Salani, Optimization at Container Terminals: Status. Trends and Perspectives. 7<sup>Th</sup> Swiss Transport Research Conf. Monte Verita/ Ascona, September 12-14, 2007.
- [16] C. H. Yang, Y. SChoi, T. Y. Ha, Simulation-Based Performance Evaluation of Transport Vehicles at Automated Container Terminals. OR Spectrum, 26, 149-170, 2004.
- [17] W. Y. Yun, Y. S. Choi, A Simulation Model For Container Terminal Operation Analysis Using An Object-Oriented Approach. Int. J. Production Economics, 59, 221-230, 1999.



