

Lead-Lag Controllers Coefficients Tuning to Control Fuel Cell Based on PSO Algorithm

Noraddin Ghadimi

Young Researchers Club, Ardabil Branch, Islamic Azad University, Ardabil, Iran
Email: noradin1364@gmail.com

ABSTRACT

One of the most important Fuel cells (FCs) is Proton Exchange Membrane Fuel Cells (PEMFCs). The output voltage of this FC depends on current loads. This paper tries to introduce, implement and control the voltage of PEMFC, during load variations. The output voltage of fuel cell should be constant during load variation. To achieve this goal, a controller should be designed. Here, the Lead-Lag controller is used which its coefficients are optimized based on PSO algorithms. In order to use this algorithm, first this problem has to be formulated as an optimization problem, including objective function and constraints, and then to obtain the most desirable controller, PSO method is used to solve the problem. Simulation results for various loads in the time domain are performed and the results show the capability of the proposed controller. Simulations show the accuracy of the proposed controller performance to achieve this goal.

KEYWORDS: PEMFC, Fuel cell, Controller Design, PSO algorithm.

INTRODUCTION

Proton exchange membrane fuel cells (PEMFCs) include a cathode and an anode, and a leading proton between the anode and cathode is like an electrolyte. Hydrogen gas (H₂), which is obtained from the methanol (CH₃OH), is inserted into the end of the anode blade (negative electrode), and also oxygen or air at the end of the positive electrode of the cell (cathode) [1].

To produce electrical energy from the fuel cell, it is essential that the output voltage of cell kept constant for different loads to supply high quality power to the loads. But fuel cell output voltage changes for different loads. In order to keep the fuel cell voltage constant, using a controller is vital. The simplest type of controller which can be used is a LEAD-LAG controller.

In reference [1], a type of fuzzy controller to control the fuel cell output voltage is proposed. In

order to control the voltage and current of the fuel cell, in reference [2] BP and RBF networks are used. The speed and accuracy of the proposed algorithms in reference [2] for this system are desirable. In reference [3], artificial neural networks are used to control the temperature of the fuel cell. To achieve good and efficient control, reference [4] utilized an optimized neural controller with Cerebella Model Articulation Controller (CMAC). In reference [5], a reinforcement learning adaptive controller for this system is presented, which adjusts controller coefficients online during load variations.

Studied fuel cell, is of the multiple fuel cells, but it is assumed that the anode and cathode mass has been compressed in anode and cathode as a fuel cell [6].

Any of the proposed methods are used to control

only one parameter of the fuel cell, which in the methods, fuzzy or neural network are used. Some of these systems initially detect and then control the system, that in turn this will make slow the control task and in some cases causing long transient response. In the reference [5], a controller, which also has an adaptive PID controller, output results depend heavily upon initial conditions.

In this paper, first PID controller problems are expressed in reference [5], and shown by simulations, and in correction of that a simple Lead-Lag Controller to control fuel cell voltage has been utilized. Except that the controller design has not been achieved through trial and error method, however, to obtain these coefficients, PSO is used. Initially, the problem has been formulated as an optimization problem and then solved using the PSO algorithm and optimal results for proposed controller coefficients are obtained. This system is simulated in MATLAB software.

I. STUDIED SYSTEM

To study the dynamic model of the fuel cell, firstly, the general schematic, structure and function of the fuel cell should be studied. The schematic system of the fuel cell that will be studied in this paper is shown in Fig. 1. The mass of the anode and cathode in the figure is considered as a sole compression of anode and cathode [6].

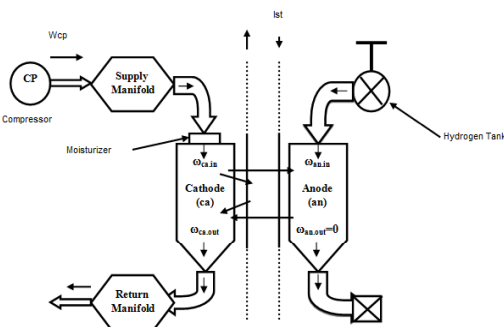

Fig. 1. Fuel cell and its supplied system

In this paper, the dynamic model of the fuel cell

is considered according to the reference [1]. The output voltage of the fuel cell is obtained by subtracting the voltage drops from the regressive voltage. Equation (1) shows how to calculate the fuel cell output voltage [6], [7] and [8].

$$V_s = n(E_{reversible} - V_{act} - V_{ohmic} - V_{con}) \quad (1)$$

Where, V_s is the accumulated fuel cell output voltage in volts, n is the existing cells in the accumulated fuel cell, V_{act} is the voltage drop resulting from anode and cathode activity in volts, V_{ohmic} is the ohmic voltage drop in volts, which is a certain amount of resistance in the transfer of electrons and protons in the electrolyte between the anode and cathode. V_{con} is resulting from the mass transfer of oxygen and hydrogen. $E_{reversible}$ in equation (1) is calculated through the following equations [1] and [9].

$$E_{reversible} = 1.229 - 0.85 \times 10^{-3}(T - 298.15) + 4.3085 \times T \times [\ln(P_{H_2}) + 0.5 \ln(P_{O_2})] \quad (2)$$

Where, T is the cells temperature in Kelvins, P_{H_2}, P_{O_2} are effective partial pressure (atm) of hydrogen and oxygen gases respectively that can be calculated by the following equation.

$$P_{O_2} = P_c - P_{H_2O}^{sat} - P_{N_2}^{channel} \exp\left(\frac{0.291\left(\frac{i}{A}\right)}{T^{0.932}}\right) \quad (3)$$

$$P_{H_2} = 0.5 P_{H_2O}^{sat} \left[\frac{1}{\exp\left(\frac{1.635\left(\frac{i}{A}\right)}{T^{1.334}}\right) \left(\frac{P_{H_2O}^{sat}}{P_a}\right)} - 1 \right] \quad (4)$$

Where, P_a and P_c are the anode and cathode inlet pressure in atmospheres, A is the effective electrode area in Cm^2 , i is the current of each cell in amperes, $P_{H_2O}^{sat}$ is the amount of saturated steam pressure that its value depends on the fuel cell. $P_{N_2}^{channel}$ is the partial pressure of N_2 in the cathode gas flow channels in atmospheres which can be calculated by the following equation.

$$P_{N_2}^{channel} = \frac{0.79}{0.21} PO_2 \quad (5)$$

All amounts used in this article, are the same data available in the reference [1].

II. PARTICLE SWARM ALGORITHM

A. INTRODUCING PSO ALGORITHM

The intelligent methods search different parts of the solution space to find the solution of the optimization problem. So they can provide an appropriate solution for a particular problem in an acceptable time, but one cannot be sure that the obtained solution is an absolute optimum point for the problem. The most important advantage of this algorithm is that they do not need auxiliary conditions such as derivatives and boundary conditions and the only criteria used is the objective function.

PSO algorithms are inspired by the social behavior related to the animal categories such as bird flock and fish group. Individuals in the population are called a particle. Each particle is the potential solution for the optimization problem trying to search the best position in a multi-dimensional space. Each particle is determined with two vectors in the search space, i.e. position vector $X = [X_1, X_2, \dots, X_d]$ and velocity vector $V = [V_1, V_2, \dots, V_d]$. Between searches particles, each particle corrects itself using its current speed and previous experience and neighboring particles experience. The best position of the i th particle, which has been found so far, $PB = [Pb_1, Pb_2, \dots, Pb_n]$ is called the particle best and the best position in the whole particles $GB = [Gb_1, Gb_2, \dots, Gb_n]$ is called the global particle. In any iteration, velocity values and all positions will be updated. In any iteration the velocity of i th particle is updated using equation (6). The figures of this update are shown in Fig 2.

$$V_i^{k+1} = \omega V_i^k + c_1 r_1 (PB_i^k - X_i^k) + c_2 r_2 (GB_i^k - X_i^k) \quad (6)$$

After that, the speed of all particles has been updated; particles with new speed moving to the new positions using the equation (7).

$$X_i^{k+1} = X_i^k + V_i^{k+1} \quad (7)$$

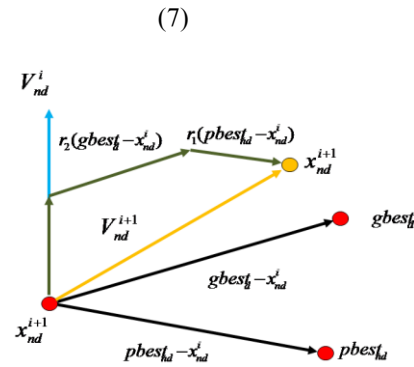

Fig. 2. updating of particles in PSO

Which c_1 and c_2 are the acceleration coefficients, r_1 and r_2 are the random values with normal distribution in the range of (0,1). X_{id} is the current position of particle, PBi is the best individual position of each particle in the previous iterations, GB is the best global position of particles in previous iterations and the coefficient ω is the inertia coefficient. Usually in the algorithm implementation, the value of inertia coefficient is set during learning and, generally, is decreased linearly from the value of unity to near the zero according to the equation (8).

$$\omega = \omega_{\max} - \frac{\omega_{\max} - \omega_{\min}}{iter_{\max}} . iter \quad (8)$$

Which $iter_{\max}$ is the maximum number of iterations and $iter$ is the number of current iteration. The velocity of velocity V_i (velocity vector) in each dimension is limited in the range of $[-V_{\max}, +V_{\max}]$ to reduce the probability of leaving the search space by particle. PSO

algorithm is performed with the following steps:

Step 1) (Initialize): put iteration $k = 0$ and n particles with initial position $X^0 = [X_1^0, X_2^0, \dots, X_d^0]$ and initial velocity $V^0 = [V_1^0, V_2^0, \dots, V_d^0]$ which are generated randomly. Calculate the objective function $f(X^0)$ for each particle, If no constraint is violated, put $PB^0 = X^0$ and select, among all particles, a particle with the lowest objective function and put it equal to GB^0 , otherwise, the initial generation of particles will be repeated.

Step 2) Update the iteration parameter $k = k + 1$.

Step 3) Update particles velocity using the equation (6).

Step 4) Update particles position using the equation (7).

Step 5) Update the best particle (BP):

If $f(X^k) < f(X^{k-1})$, therefore put $PB^k = X^k$ otherwise put $PB^k = PB^{k-1}$

Step 6) Update the best particle among the particles (GB): $f(GB^k) = \min\{f(PB^k)\}$

If $f(GB^k) < f(GB^{k-1})$ hence put $GB^k = GB^k$ otherwise $GB^k = GB^{k-1}$.

Step 7) Program termination criteria: if the number of iterations is more than the maximum number of predetermined iterations the program will stop, and otherwise return back to step 2.

B. Using PSO to adjust control parameters

Despite many developments in control systems and their applicability, simple controllers in systems are still considered desirable controllers [12]. In most cases, compensators in power systems are lead-lag controllers. These controllers could be implemented easily in analog and/or digital systems. In this study, lead-lag controllers are used to control the voltage of proton exchange membrane fuel cell. The overall controller schematic is shown in Fig. 3. Parameters which should be controlled in the controller area T_p, T_z, K_p , it is clear that the

transient state of the system in load changes depends on these coefficients of controller. Controller design methods here could not be implemented, since the system is fully nonlinear system, therefore these methods have not efficient performance in this system.

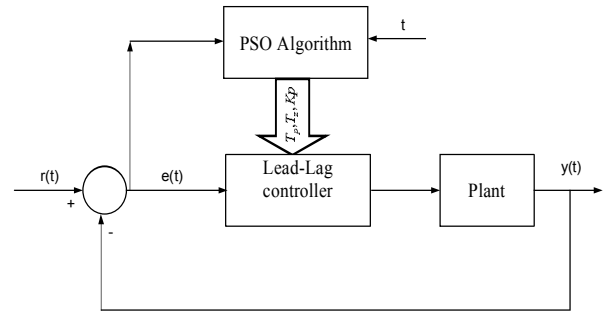

Fig.3. Block diagram of the proposed controller to control fuel cell voltage

In order to design controller using PSO algorithm for this system based on the curve of the wind changes, we consider the worst conditions, and controller is designed for these conditions. Fig. 4 shows the worst considered changes in this system in voltage 20v.

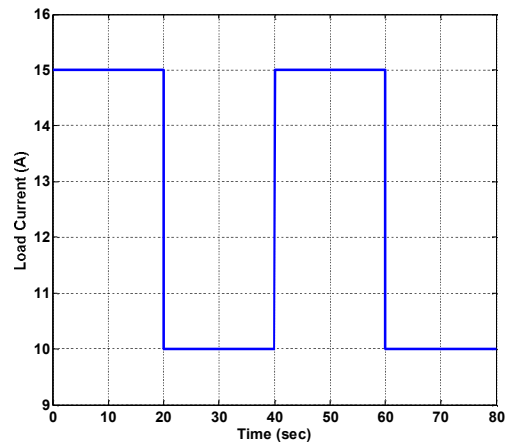

Fig. 4. Bad conditions of load current considered for the studied system

Now, the problem must be formulated as an optimization problem and then be solved. Choosing an objective function is the main part of this optimization problem. Because the choice of objective functions may completely change how the particles will move. In our optimizing problem, here, we use the error signal.

$$J = \int_0^{t=tsim} |v_{out} - v_{ref}| dt \quad (9)$$

Where $tsim$ is the simulation time during which the objective function is calculated. It should be noted that the more the objective function is smaller the more the solution is optimum. Each optimization problem is expressed under a number of constraints which in this problem, constraints are expressed as follows.

Minimize J subject to

$$T_p^{min} \leq T_p \leq T_p^{max}$$

$$T_z^{min} \leq T_z \leq T_z^{max}$$

$$K_p^{min} \leq K_p \leq K_p^{max}$$

(10)

Where, T_p, T_z is within the interval [0.01 50] and K_p is in the interval [0.01 5].

In the optimization problem, the number of particles, particles dimensions and the number of iterations have been selected 30, 3 and 60, respectively. After the optimization results are determined as follows.

$$T_p = 0.34515, T_z = 0.1165, K_p = 0.5578$$

(11)

SIMULATION RESULTS

In this section, simulation results are performed for five different conditions, and output results obtained using proposed controller is compared with a controller in reference [5].

C. SIMULATION RESULTS WITH REFERENCE CONTROLLER IN [5]

In reference [5], a controller is proposed based on reinforcement learning adaptive algorithm. This controller changes lead-lag coefficients online manner. If the varying steps get long, it is likely to reach a not more satisfied solution. But, if these variations are low, in these conditions, the algorithm needs to find an appropriate initial value for lead-lag coefficients. Fig.5 shows anode and cathode gas pressure, load

current, output voltage and the reference voltage with initial conditions expressed in Eq (9).

$$K_p = 1, K_i = 1, K_d = 0.1 \quad (12)$$

Fig. 6 shows appropriately the output voltage and reference voltage with initial conditions expressed in Eq (12). And fig. 6 shows the output voltage and the reference voltage with initial conditions expressed in Eq (13). According to the results it is obvious that output voltage depends on the initial conditions, since results are different from each other.

$$K_p = 15, K_i = 1, K_d = 0.2$$

(13)

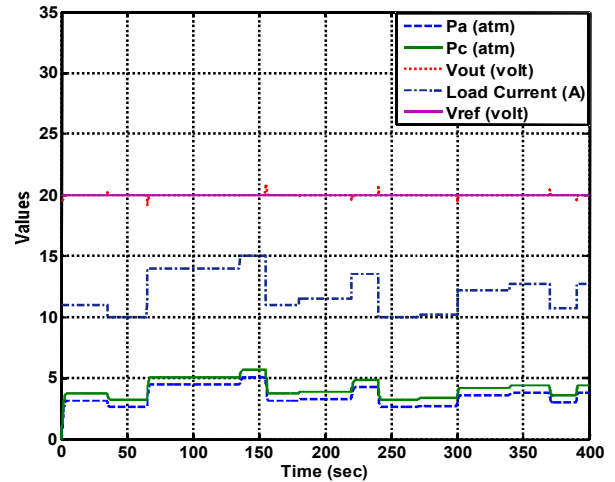

Fig. 5. Anode and cathode gas pressures, load current, output voltage and reference voltage PID controller in Eq (12)

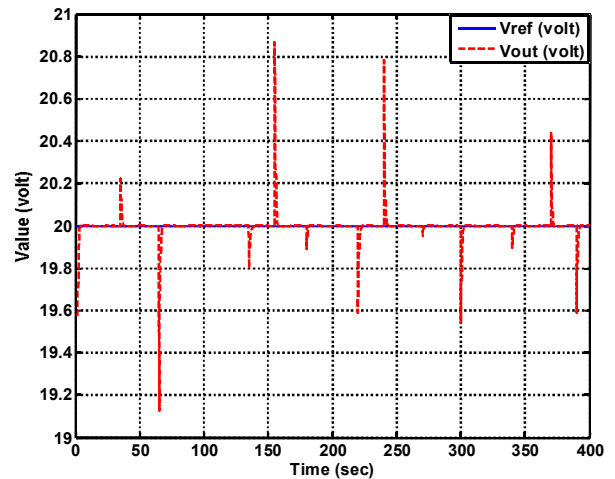

Fig. 6. Output voltage of load and reference voltage with PID coefficients in Eq (12)

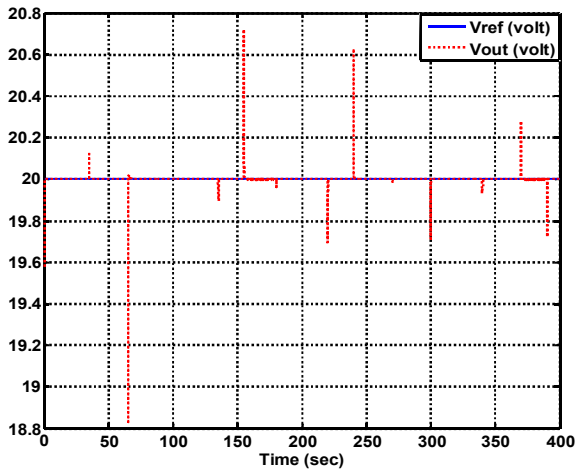

Fig.7.Output voltage of load and reference voltage with PID coefficients in Eq (13)

D. SIMULATION RESULTS WITH PROPOSED CONTROLLER

Simulation results using obtained coefficients proposed algorithm expressed in Eq (11) are shown in Figs. (8-10). Fig. 8 shows anode and cathode gas pressures, load current, output voltage and reference voltage. Output load voltage and reference voltage are shown in fig. 9, and according to the figure it is clear that results are improved and are better than the previous modes. Created peaks in this mode are lower than the previous coefficients. Also, the error between the output and reference voltages is shown in fig. 10 which shows the high efficacy of the proposed algorithm.

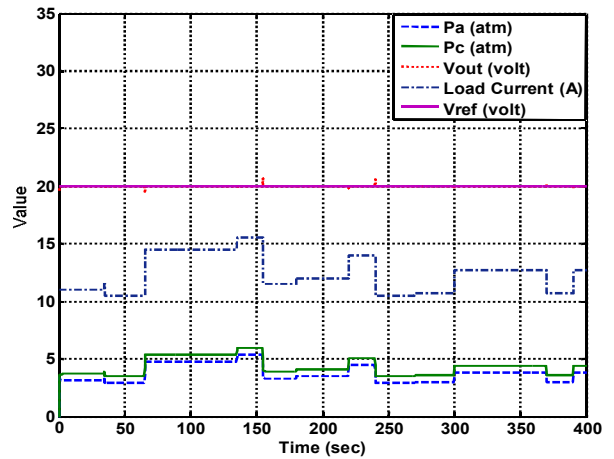

Fig. 8. Anode and cathode gas pressures, load current, output voltage and reference voltage with proposed controller

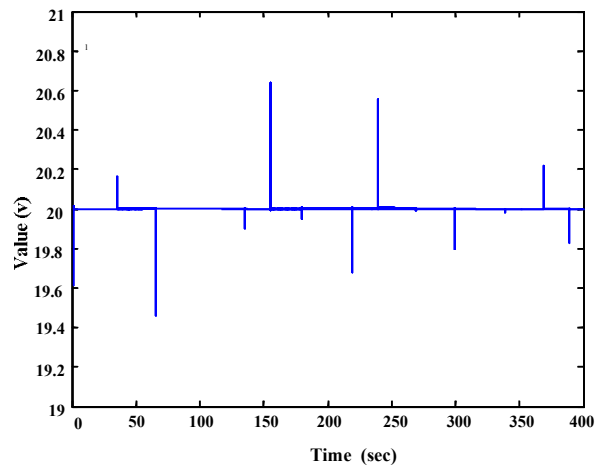

Fig.9. Output voltage and reference voltage with proposed controller

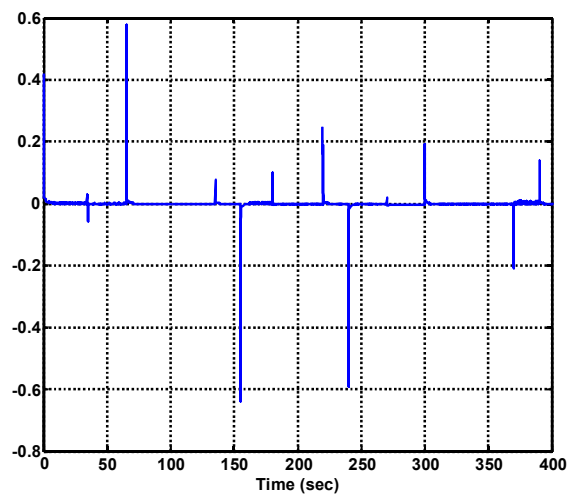

Fig.10. The error between output and reference voltages

E. COMPARISON WITH GA CONTROLLER

In this section Results of proposed controller will be compared with GA algorithm controller [13]. Simulation results using obtained coefficients proposed algorithm using GA controller and proposed controller are shown in Figs. (11). Zooming on peak value at $t=155s$ shows that the proposed PSO based controller is better than pervious GA based controller. With PSO based controller, the maximum peak and settling time value are less than GA based controller.

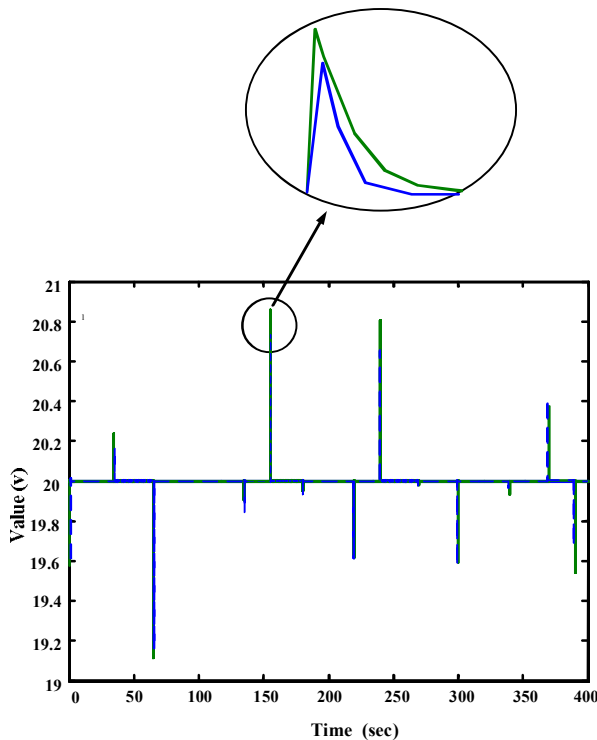

Fig.11. Result comparison with GA based algorithm

CONCLUSION

In this paper, a controller based on PSO Algorithm and lead-lag controller was suggested to control the fuel cell output voltage. The controller has been chosen because it is simple and resolves the problem of the previous controller and its performance is higher than previous controllers. PSO algorithm was utilized

to design the lead-lag controllers and has the most optimum state. In solving this problem, first the problem is formulated as an optimization problem which its objective function was defined in the time domain and then solved using PSO algorithms. And the most optimum mode for lead-lag coefficients were determined using this algorithm.

Proposed controller could improve the transient state of current and voltage. This claim within the different states of loads was verified using simulation in MATLAB software in a time domain system.

REFERENCES

- [1] Mo Zhigun, Zhu Xinjian and Cao Guangyi “ Design and Simulation of Fuzzy Controller for PEMFCs” IEEE Conference. 2005,pp220-224.
- [2] Anucha Saengrung, Amir Abtahi, Ali Zilouchian “Neural network model for a commercial PEM fuel cell system” Journal of Power Sources vol.172,pp.749-759,2007.
- [3] Yanjun Li, Houjun Wang, Zhijian Dai “Using Artificial Neural Network to Control the Temperature of Fuel Cell” IEEE Conference 2006,pp.2159-2162.
- [4] Almeida P.E.M and Simoes M.G” Neural Optimal Control of PEMFC with Parametric CMAC Network” Industry Application Conference,38th IAS Annual Meeting. Vol.2,pp.723-730,2003.
- [5] Hossein Kazemi Karegar, B.Sobhani, M.S.Toulabi” A New Adaptive Voltage Controller for PEMFCs Based on Reinforcement Learning Method”
- [6] Liyan Zhang, Mu Pan, Shuhai Quan, Qihong Chen and Ying Shi “ Adaptive Neural Control Based on PEMFC Hybrid Model” Proceedings of the 6th World Congress on Intelligent Control and Automation, June 21-23 2006 IEEE, Dalian China.
- [7] Larminie.J.Dicks,A” Fuel Cell Systems Explained” Wiley, London,2001.
- [8] Zhan Yuedong, Zhu Jianguo, Guo Youguang, Jin Jianxun, “Control of Proton Exchange Membranes Fuel Cell Based on Fuzzy Logic” proceedings of the 26th Chinese Control Conference ,July 26-31 2007,Hunan China.
- [9] Mann.R.F, Amphlett.J.C, Hooper.M.A.I, et al “Development and Application of a Generalized Steady-State Electrochemical Model for a PEM Fuel Cell” Journal of Power Sources,2000, Vol 86,pp.172-180
- [10] Trung V.Nguen and Ralph E.White“ A Water and Heat Management Model for Proton-Exchange-membrane Fuel Cells” Journal of Electrochemical Society , vol.140,no.8,pp.2178-2186,1993.

- [11] R.L Haupt, S.L.Haupt, Practical genetic algorithms, 2nd edition, John Wiley, 2004
- [12] H. Shayeghi, H.A. Shayanfar, A. Safari, R. Aghmasheh “A robust PSSs design using PSO in a multi-machine environment” Energy Conversion and Management 51 (2010) 696–702
- [13] H. Nasir aghdam, N. Ghadimi, A. Ataei “Adjusting PID Controllers Coefficients to Control Fuel Cell using Genetic Algorithm” 10th International Conference On Environment And Electrical Engineering (EEEIC),8-11 May 2011,Rome Italy