

Mathematical Analysis of Newly Designed Two Porous Layers Slider Bearing with a Convex Pad Upper Surface Considering Slip and Squeeze Velocity using Ferrofluid Lubricant

Rajesh C. Shah^{a,*} and Ramesh C. Kataria^b

^aDepartment of Applied Mathematics, Faculty of Technology & Engineering,
The M. S. University of Baroda, Vadodara – 390 001, Gujarat State, India.

^bDepartment of Mathematics, Som-Lalit Institute of Computer Applications,
Ahmedabad – 380 009, Gujarat State, India.

Abstract. This paper proposes mathematical modelling and analysis of ferrofluid lubricated newly designed slider bearing having convex pad (surface or plate) stator with two porous layers attached to the slider. The problem considers the effect of slip velocity proposed by Sparrow *et. al.*[17] and modified by Shah *et. al.*[9] at the film-porous interface. The squeeze velocity $V = -\dot{h}$, which appears when the upper impermeable plate approach to the lower one, is also considered here for study. The magnetic field is assumed to be oblique to the lower plate. From the Reynolds's equation of the above model, expressions for dimensionless form of pressure and load carrying capacity are obtained. The expression for the dimensionless load carrying capacity is then solved numerically to examine its possible effect on the designed bearing system. From the results it is concluded that

(1) When $k_1 > k_2$, dimensionless load carrying capacity increases about 6.35 % for both $\dot{h} = 0$, and $\dot{h} \neq 0$ as compared to $k_1 < k_2$.

(2) The dimensionless load carrying capacity increases about 113 % for both $\dot{h} = 0$ and $\dot{h} \neq 0$ when $k_1 = k_2 = 0.0001$ as compared to $k_1 = k_2 = 0.01$.

In the above results k_1 and k_2 represents the permeabilities of the upper and lower porous layers (matrixes) respectively

Received: 20 May 2013; Revised: 5 August 2013; Accepted: 14 September 2013.

Keywords: Ferrofluid, Squeeze velocity, Porosity, Lubrication, Slip velocity, Convex bearing

Index to information contained in this paper

1. Introduction
2. Formulation of the Mathematical Model
3. Results and Discussion
4. Conclusion

*Corresponding author. Email: dr_rcshah@yahoo.com

1. Introduction

Ferrofluids or Magnetic fluids [8] are stable colloidal suspensions containing fine ferromagnetic particles dispersing in a liquid, called carrier liquid (in our case water), in which a surfactant is added to generate a coating layer preventing the flocculation of the particles. When an external magnetic field is applied, ferrofluid can experience magnetic body forces depend upon the magnetization of ferromagnetic particles. Owing to these features ferrofluids are useful in many applications like in sensors, sealing devices, filtering apparatus, etc.[4].

Wu [20] in an innovative analysis, dealt with the case of squeeze film behaviour for porous annular disks in which he showed that owing to the fact that fluid can flow through the porous material as well as through the space between the bounding surfaces, the performance of a porous walled squeeze film can differ substantially from that of a solid walled squeeze film. Later [17] extended the above analysis of [20] by introducing the effect of velocity slip to porous walled squeeze film with porous matrix attached to the above plate. They found that the load carrying capacity decreases due to the effect of porosity and slip. Prakash and Vij [7] investigated a porous inclined slider bearing without the effect of magnetic fluid and found that porosity caused decrease in the load capacity and friction, while it increases the coefficient of friction. Gupta and Bhat [5] found that the load capacity and friction could be increased by using a transverse magnetic field using conducting lubricant.

With the advent of ferrofluid, Agrawal [1] studied its effects on a porous inclined slider bearing and found that the magnetization of the magnetic particles in the lubricant increases load capacity without affecting the friction on the moving slider. In [19] Verma studied squeeze film bearing with magnetic fluid as lubricant using three porous layers attached to the lower plate and showed that load carrying capacity increases due to the effect of magnetic fluid lubricant as compared to conventional viscous fluid as lubricant. Shah *et.al.* in [10, 11] studied respectively convex pad porous surface slider bearing with slip velocity and axially undefined journal bearing with anisotropic permeability, slip and squeeze velocity. In both the papers lubricant used was ferrofluid and showed that the performance of the bearing is better.

Other references [3,16,12,2,6,15,14] have also analyzed effects of ferrofluids in their study from different viewpoints.

In all above investigations, none of the authors in their study considered the effects of two porous layers attached to the lower plate (slider) for a slider bearing having convex pad stator with slip and squeeze velocity using ferrofluid as a lubricant. The porous layer in the bearing is considered because of its advantageous property of self lubrication. With this motivation the present paper propose the study of performance of a slider bearing having convex pad stator with two porous layers attached to the lower plate with a ferrofluid lubricant under a magnetic field oblique to the lower surface. Here, the effects of slip velocity at the film and porous interface, as well as squeeze velocity when the upper plate approaches to lower one are also included for study. The ferrofluid flow model considered is due to R. E. Rosensweig [8] and the ferrofluid used in the computations are water based.

A mathematical model of the above problem in the form of Reynolds's equation is derived. Fixed size of porous matrix is considered for computation of dimensionless load carrying capacity for same as well as different values of the permeabilities k_1 and k_2 of the upper and

lower porous matrixes respectively as shown in figure 1. The results are also obtained when squeeze velocity $\dot{h} = 0$ and $\dot{h} \neq 0$.

2. Formation of the Mathematical Model

The configuration of the slider bearing having convex pad stator with squeeze velocity \dot{h} is displayed in figure 1.

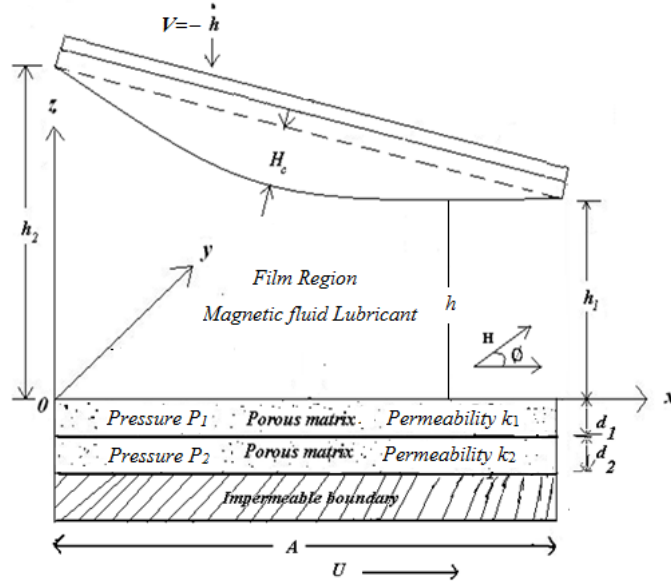

Figure 1. Convex pad surface slider bearing.

The lower surface (slider) is of having length A and moving with uniform velocity U in the x -direction, the upper convex pad surface is a stator with central thickness H_c . The film thickness is h and given by expression (refer [10])

$$h = H_c \left\{ 4 \left(\frac{x}{A} - \frac{1}{2} \right)^2 - 1 \right\} + h_1 \left\{ a - \frac{a}{A} x + \frac{x}{A} \right\}; \quad a = \frac{h_2}{h_1}, \quad 0 \leq x \leq A, \quad (1)$$

where h_2 and h_1 are maximum and minimum film thickness respectively.

The slider has attached porous matrix of thickness d_2 first and then d_1 as shown in figure 1. The stator moves normally towards the slider with a uniform velocity

$$\dot{h} = dh / dt,$$

where t is time.

The basic flow equations governing the above phenomenon based on R. E. Rosensweig's model are given by [13]

$$\rho \left[\frac{\partial \mathbf{q}}{\partial t} + (\mathbf{q} \cdot \nabla) \mathbf{q} \right] = -\nabla p + \eta \nabla^2 \mathbf{q} + \mu_0 (\mathbf{M} \cdot \nabla) \mathbf{H} \quad (2)$$

$$\nabla \cdot \mathbf{q} = 0 \quad (3)$$

$$\nabla \times \mathbf{H} = 0 \quad (4)$$

$$\mathbf{M} = \bar{\mu} \mathbf{H} \quad (5)$$

$$\nabla \cdot (\mathbf{H} + \mathbf{M}) = 0. \quad (6)$$

where ρ , p , η , \mathbf{q} , μ_0 , \mathbf{M} , \mathbf{H} , $\bar{\mu}$ are density, film pressure, fluid viscosity, fluid velocity, free space permeability, the magnetization vector, magnetic field vector and magnetic susceptibility respectively. Also,

$$\mathbf{q} = u \mathbf{i} + v \mathbf{j} + w \mathbf{k}, \quad (7)$$

where u , v , w are components of film fluid velocity in x , y and z –directions respectively.

The magnetic field considered here is oblique to the lower surface and is defined as

$$H^2 = Kx(A-x), \quad (8)$$

where K is chosen to suit the dimensions of both sides.

By combining above Equations (2) to (7) under the usual assumption of lubrication, neglecting inertia terms and that the derivatives of velocities across the film predominate, equation governing the lubricant flow in the film region in x -direction yields

$$\frac{\partial^2 u}{\partial z^2} = \frac{1}{\eta} \frac{\partial}{\partial x} \left(p - \frac{1}{2} \mu_0 \bar{\mu} H^2 \right). \quad (9)$$

Using slip boundary conditions [9]

$$u = \frac{1}{s} \frac{\partial u}{\partial z} + U ; \quad \frac{1}{s} = \frac{\sqrt{k_1}}{\alpha} \text{ when } z = 0, \quad (10)$$

and

$$u = 0 \text{ when } z = h, \quad (11)$$

Equation (9) becomes

$$u = \frac{(h-z)s}{(1+sh)} U + \left\{ \frac{(z+h+shz)(z-h)}{2\eta(1+sh)} \right\} \frac{\partial}{\partial x} \left(p - \frac{1}{2} \mu_0 \bar{\mu} H^2 \right), \quad (12)$$

where s represents slip parameter, α represents slip coefficient and k_1 represents permeability of the upper porous layer. All are dependent on the structure of the porous material.

Continuity equation for the film region is given by

$$\frac{\partial u}{\partial x} + \frac{\partial w}{\partial z} = 0. \quad (13)$$

Integrating continuity Equation (13) for the film thickness h ; that is, from 0 to h , and making use of Equation (12), yields

$$\frac{\partial}{\partial x} \left\{ \frac{sh^2}{2(1+sh)} U - \frac{h^3(4+sh)}{12\eta(1+sh)} \frac{\partial}{\partial x} \left(p - \frac{1}{2} \mu_0 \bar{\mu} H^2 \right) \right\} = w_0 - V, \quad (14)$$

as $w|_{z=h} = w_h = V = -\dot{h}$, which represents squeeze velocity in the downward z - direction.
Also,

$$w|_{z=0} = w_0.$$

The velocity components in the porous region are given by

$$\bar{u}_i = -\frac{k_i}{\eta} \frac{\partial P_i}{\partial x} + \frac{\mu_0 \bar{\mu} k_i}{2\eta} \frac{\partial H^2}{\partial x} \quad (x \text{ - direction}), \quad (15)$$

$$\bar{w}_i = -\frac{k_i}{\eta} \frac{\partial P_i}{\partial z} + \frac{\mu_0 \bar{\mu} k_i}{2\eta} \frac{\partial H^2}{\partial z} \quad (z \text{ - direction}), \quad (16)$$

where $i = 1, 2$ represents index of velocity components in the porous matrix of thickness d_1 and d_2 respectively and k_1, k_2 are permeabilities there (Refer Figure 1).

Considering continuity of the flow between two porous layers d_1 and d_2 with respect to z , one obtains

$$\left[-\frac{k_1}{\eta} \frac{\partial P_1}{\partial z} + \frac{\mu_0 \bar{\mu} k_1}{2\eta} \frac{\partial H^2}{\partial z} \right]_{z=-d_1} = \left[-\frac{k_2}{\eta} \frac{\partial P_2}{\partial z} + \frac{\mu_0 \bar{\mu} k_2}{2\eta} \frac{\partial H^2}{\partial z} \right]_{z=-d_1}. \quad (17)$$

Also, at the surface of the impermeable lower plate

$$\left[-\frac{k_2}{\eta} \frac{\partial P_2}{\partial z} + \frac{\mu_0 \bar{\mu} k_2}{2\eta} \frac{\partial H^2}{\partial z} \right]_{z=-(d_1+d_2)} = 0. \quad (18)$$

Using Equations (15) and (16) in the continuity equation for porous region

$$\frac{\partial \bar{u}}{\partial x} + \frac{\partial \bar{w}}{\partial z} = 0,$$

yields

$$\frac{\partial^2}{\partial x^2} \left(P_i - \frac{1}{2} \mu_0 \bar{\mu} H^2 \right) + \frac{\partial^2}{\partial z^2} \left(P_i - \frac{1}{2} \mu_0 \bar{\mu} H^2 \right) = 0, \quad (19)$$

where $i = 1, 2$.

Integrating Equation (19) with respect to z over the porous layer of the thickness d_1 , yields

$$\left. \frac{\partial}{\partial z} \left(P_i - \frac{1}{2} \mu_0 \bar{\mu} H^2 \right) \right|_{z=0} - \left. \frac{\partial}{\partial z} \left(P_i - \frac{1}{2} \mu_0 \bar{\mu} H^2 \right) \right|_{z=-d_1} = - \int_{-d_1}^0 \frac{\partial^2}{\partial x^2} \left(P_i - \frac{1}{2} \mu_0 \bar{\mu} H^2 \right) dz. \quad (20)$$

Again, integrating Equation (19) with respect to z over the porous layer of the thickness d_2 , yields

$$\left. \frac{\partial}{\partial z} \left(P_2 - \frac{1}{2} \mu_0 \bar{\mu} H^2 \right) \right|_{z=-d_1} - \left. \frac{\partial}{\partial z} \left(P_2 - \frac{1}{2} \mu_0 \bar{\mu} H^2 \right) \right|_{z=-(d_1+d_2)} = - \int_{-(d_1+d_2)}^{-d_1} \frac{\partial^2}{\partial x^2} \left(P_2 - \frac{1}{2} \mu_0 \bar{\mu} H^2 \right) dz. \quad (21)$$

Using condition (17), Equation (20) becomes

$$\left. \frac{\partial}{\partial z} \left(P_1 - \frac{1}{2} \mu_0 \bar{\mu} H^2 \right) \right|_{z=0} = - \int_{-d_1}^0 \frac{\partial^2}{\partial x^2} \left(P_1 - \frac{1}{2} \mu_0 \bar{\mu} H^2 \right) dz + \frac{k_2}{k_1} \left. \frac{\partial}{\partial z} \left(P_2 - \frac{1}{2} \mu_0 \bar{\mu} H^2 \right) \right|_{z=-d_1} . \quad (22)$$

Using Equations (18) and (21), Equation (22) becomes

$$\left[\frac{\partial}{\partial z} \left(P_1 - \frac{1}{2} \mu_0 \bar{\mu} H^2 \right) \right]_{z=0} = - \left(d_1 + \frac{k_2}{k_1} d_2 \right) \frac{d^2}{dx^2} \left(p - \frac{1}{2} \mu_0 \bar{\mu} H^2 \right), \quad (23)$$

using Morgan-Cameron approximation [9].

As the normal component of velocity across the film – porous interface are continuous, therefore

$$w|_{z=0} = \bar{w}|_{z=0} . \quad (24)$$

Using equation (16) at $z = 0$, Equations (23), (24) and the fact that $\partial H^2 / \partial z = 0$, Equation (14) becomes

$$\frac{d}{dx} \left[\left\{ 12 k_1 \left(d_1 + \frac{k_2}{k_1} d_2 \right) + \frac{h^3 (4 + sh)}{(1 + sh)} \right\} \frac{d}{dx} \left(p - \frac{1}{2} \mu_0 \bar{\mu} H^2 \right) \right] = 12 \eta V + 6 \eta U \frac{d}{dx} \left(\frac{sh^2}{1 + sh} \right), \quad (25)$$

which is known as Reynolds's equation of the considered phenomena.

Defining dimensionless quantities

$$X = \frac{x}{A}, \quad \bar{h} = \frac{h}{h_1}, \quad \bar{s} = s h_1, \quad a = \frac{h_2}{h_1}, \quad \bar{p} = \frac{h_1^2 p}{\eta U A}, \quad \mu^* = \frac{\mu_0 \bar{\mu} K A h_1^2}{\eta U},$$

$$\psi = \frac{k_1 d_1 + k_2 d_2}{h_1^3}, \quad S = \frac{-2 VA}{U h_1}, \quad (26)$$

the magnetic field H defined in equation (8) becomes

$$H^2 = K A^2 X(1 - X), \quad (27)$$

and the Equation (25) becomes

$$\frac{d}{dX} \left[G \frac{d}{dX} \left\{ \bar{p} - \frac{1}{2} \mu^* X(1 - X) \right\} \right] = \frac{dE}{dX}, \quad (28)$$

where

$$G = 12 \psi + \frac{\bar{h}^3 (4 + \bar{s} \bar{h})}{(1 + \bar{s} \bar{h})}, \quad E = \frac{6 \bar{s} \bar{h}^2}{(1 + \bar{s} \bar{h})} - 6 S X. \quad (29)$$

Equation (28) is known as Reynolds's equation in dimensionless form.

Solving Equation (28) under the boundary conditions

$$\bar{p} = 0 \text{ when } X = 0, 1, \quad (30)$$

yields

$$\bar{p} = \frac{1}{2} \mu^* X(1 - X) + \int_0^X \frac{E - Q}{G} dX, \quad (31)$$

where

$$Q = \frac{\int_0^1 \frac{E}{G} dX}{\int_0^1 \frac{1}{G} dX} .$$

The load carrying capacity W of the bearing can be expressed in dimensionless form as

$$\bar{W} = \int_0^1 \bar{p} dX ,$$

where

$$\bar{W} = \frac{w h_1^2}{B \eta U A^2} .$$

Using Equation (31),

$$\bar{W} = \frac{w h_1^2}{B \eta U A^2} = \frac{\mu^*}{12} - \int_0^1 \frac{E - Q}{G} X dX . \quad (32)$$

3. Results and Discussion

The values of the dimensionless load carrying capacity \bar{W} has been calculated for the following value of the parameters using Simpson's 1/3 rule with step size 0.1.

$$\begin{aligned} h_1 &= 0.05(m), h_2 = 0.10(m), \bar{\mu} = 0.05, U = 1 (ms^{-1}), \\ A &= 0.15(m), \eta = 0.012 (kg m^{-1} s^{-1}), \mu_0 = 4\pi \times 10^{-7} (kg m s^{-2} A^{-2}), H_c = 0.3(m), \\ \dot{h} &= 0.005 (ms^{-1}), d_1 = 0.01(m), d_2 = 0.01(m), \alpha = 0.1, K = 10^9 \end{aligned}$$

The ferrofluid used here is water based. The magnetic field considered here is oblique to the lower plate and its strength is in between $O(10^2) - O(10^3)$ in order to get maximum magnetic field at $x = A / 2$.

The calculation of magnetic field strength is shown below [11]:

From Equation (8),

$$\begin{aligned} H^2 &= K x(A - x), \\ \text{Max. } H^2 &= 10^{-4} K \\ \text{For } H &= O(10^3), K = O(10^{10}) \end{aligned}$$

According to [18] the maximum magnetic field strength one can take is of $O(10^5)$.

The calculated values of \bar{W} presented by two tables:

Table 1 presents the values of \bar{W} by interchanging the values of k_1 and k_2 for two different cases of $\dot{h} = 0$ and $\dot{h} \neq 0$. It is observed from the Table that when $k_1 > k_2$, dimensionless load carrying capacity increases about 6.35 % in both the cases; that is, for $\dot{h} = 0$ and $\dot{h} \neq 0$ as compared to $k_1 < k_2$.

Table 2 presents the values of \bar{W} by considering two same values of k_1 and k_2 for two different cases of $\dot{h} = 0$ and $\dot{h} \neq 0$. It is observed from the table that the dimensionless load

carrying capacity increases about 113% for $k_1 = k_2 = 0.0001$ in both the cases; that is, for $\dot{h} = 0$ and $\dot{h} \neq 0$ as compared to $k_1 = k_2 = 0.01$.

Table 1. Values of \bar{W} for interchanging values of k_1 and k_2 considering $\dot{h} = 0$ and $\dot{h} \neq 0$

k_1	k_2	\bar{W}	
		$\dot{h} = 0$	$\dot{h} \neq 0$
0.1	0.0001	0.1620510	0.1621569
0.0001	0.1	0.1523362	0.1524624
% increase in \bar{W}		6.38	6.35

Table 2. Values of \bar{W} for same values of k_1 and k_2 considering $\dot{h} = 0$ and $\dot{h} \neq 0$

k_1	k_2	\bar{W}	
		$\dot{h} = 0$	$\dot{h} \neq 0$
0.0001	0.0001	0.3386675	0.3385819
0.01	0.01	0.1588051	0.1592045
% increase in \bar{W}		113.26	112.67

4. Conclusion

The problem on slider bearing having convex pad stator with two porous layers attached to the lower plate is discussed here for its optimum performance with a ferrofluid lubricant under a magnetic field oblique to the lower surface. The effects of slip velocity at the film and porous interface, as well as squeeze velocity when the upper plate approaches to lower one, is also considered for study. The ferrofluid flow model considered here is due to R. E. Rosensweig and the ferrofluid is considered to be of water based with magnetic field strength considered of order between $10^2 - 10^3$ in order to get maximum magnetic field at $x = A / 2$. From the results and discussion it is concluded that better dimensionless load carrying capacity can be obtained for smaller values of k_1 and k_2 and for $k_1 > k_2$.

Also, it should be noted from Equation (9) that, a constant magnetic field does not enhance load carrying capacity in Rosensweig's ferrofluid flow model.

5. References

- [1] Agrawal V. K., Magnetic fluid based porous inclined slider bearing, *Wear*, **107** (1986) 133-139.
- [2] Ahmad N., Singh J.P., Magnetic fluid lubrication of porous-pivoted slider bearing with slip velocity. *J. Engineering Tribology*, **221**(2007) 609-613.
- [3] Chi C.Q., Wang Z.S., Zhao P.Z., Research on a new type of ferrofluid – lubricated journal bearing, *Journal of Magnetism and Magnetic Materials*, **85** (1990) 257-260.
- [4] Goldowsky M., New methods for sealing, filtering, and lubricating with magnetic fluids,

- IEEE transactions on Magnetism, Mag.- **16** (1980) 382-386.
- [5] Gupta J. L., Bhat M. V., An inclined porous slider bearing with a transverse magnetic field, *Wear*, **55** (1979) 359-367.
- [6] Liu J., Analysis of a porous elastic sheet damper with a magnetic fluid, *Journal of Tribology*, **131** (2009) 0218011-15.
- [7] Prakash J., Vij S. K., Hydrodynamic lubrication of a porous slider, *Journal of Mechanical Engineering Science*, **15** (1973) 232-234.
- [8] Rosensweig R. E., *Ferrohydrodynamics*, Cambridge University Press, New York, 1985.
- [9] Shah R. C., Bhat M. V., Ferrofluid lubrication equation for porous bearing considering anisotropic permeability and slip velocity, *Indian Journal of Engineering & Materials Sciences*, **10** (2003) 277-281.
- [10] Shah R.C., Bhat M.V. , Ferrofluid lubrication of a porous slider bearing with a convex pad surface considering slip velocity, *International Journal of Applied Electromagnetic and Mechanics*, **20** (2004) 1-9.
- [11] Shah R.C., Bhat M.V., Anisotropic permeable porous facing and slip velocity on squeeze film in an axially undefined journal bearing with ferrofluid lubricant, *Journal of Magnetism and Magnetic Materials*, **279** (2004) 224-230.
- [12] Shah R. C., Bhat M. V., Ferrofluid squeeze film between curved annular plates including rotation of magnetic particles, *Journal of Engineering Mathematics*, **51** (2005) 317-324.
- [13] Shah R. C., Bhat M. V., Analysis of a porous exponential slider bearing lubricated with a ferrofluid considering slip velocity, *Journal of the Brazilian Society of Mechanical Sciences and Engineering*, **25(3)** (2003) 264-267.
- [14] Shah R.C., Parsania M.M., Comparative Study of Parallel Plate Slider Bearing with Other Slider Bearings Using Magnetic Fluid as Lubricant, *American journal of Mathematics and Statistics*, **3 (4)** (2013) 179-189.
- [15] Shah R. C., Patel D .B., Mathematical Modelling of newly designed Ferrofluid Based Slider Bearing Including Effects of Porosity, Anisotropic Permeability, Slip Velocity at Both the Ends, and Squeeze Velocity, *Applied Mathematics*, **2 (5)** (2012) 176-183.
- [16] Sinha P., Chandra P., Kumar D., Ferrofluid lubrication of cylindrical rollers with cavitation, *Acta Mechanica*, **98** (1993) 27-38.
- [17] Sparrow E. M., Beavers G.S., Hwang I.T., Effect of velocity slip on porous walled squeeze films, *Journal of Lubrication Technology*, **94** (1972) 260-265.
- [18] Tipei N., Theory of Lubrication with Ferrofluids: Application to short bearings. *Transactions of ASME*, **104**(1982) 510-515.
- [19] Verma P.D.S., Magnetic fluid-based squeeze film, *International Journal of Engineering Science*, **24(3)** (1986) 395-401.
- [20] Wu H., Squeeze - film behavior for porous annular disks, *Journal of Lubrication Technology*, *Trans. ASME, Series F*, **92(4)** (1970) 593-596.