

A Study on The Effects of Different Pad Materials on Brake System Performance of a High-Capacity Elevator by FEM Simulation

Mohammad Sajjad Mahdieh*, Farshad Nazari, Ali Riyadh Khairullah

Department of Mechanical Engineering,

Shahid Chamran University of Ahvaz, Ahvaz, Iran

E-mail: s.mahdieh@scu.ac.ir, F.nazari@scu.ac.ir, alireyadh@scu.ac.ir

*Corresponding author

Received: 19 November 2023, Revised: 20 December 2023, Accepted: 31 December 2023

Abstract: The brake system must be reliable and display unchanging action throughout its use, as it guards the health and life of many people. Properly matched friction pair, a drum, and a brake pad have a great impact on these factors. The brake pads are far more complex components. New technologies make it possible to develop materials with various compositions and different proportions and connect them permanently in fully controllable processes. This elaboration shows that all these factors have a greater or lesser impact on the coefficient of friction, resistance to friction wear and high temperature, and the brake pad's operating life. The friction materials are required to provide a stable coefficient of friction and a low wear rate at various operating speeds, pressures, temperatures, and environmental conditions. The aim of this work is therefore to investigate the possibility of using a Finite Element Analysis (FEA) approach to evaluate the braking performance of a heavy-duty elevator with different non-conventional pad materials including Composite Carbon fiber reinforced, Composite Epoxy SMC and SiC (silicon carbide). The results show that the performance of SiC (silicon carbide) is better than two other materials. In the braking system with SiC, the required time for stoppage of the system is lower than two other materials.

Keywords: Braking System, Design Enhancement, Elevator, External Shoe Brake, FEM Simulation, Pad Materials

Biographical notes: **Mohammad Sajjad Mahdieh** received his PhD in Mechanical Engineering from the University of Tehran, Iran. He is currently an Assistant Professor at the Department of Mechanical Engineering, Shahid Chamran University of Ahvaz, Iran. His research areas are inverse engineering, 3D printing and metal forming. **Farshad Nazari** is currently an Assistant Professor at the Department of Mechanical Engineering, Shahid Chamran University of Ahvaz, Iran. His research areas are 3D printing and metal forming. **Ali Riyadh Khairullah** is an international MSc student at the Department of Mechanical Engineering, Shahid Chamran University of Ahvaz, Iran.

Research paper

COPYRIGHTS

© 2023 by the authors. Licensee Islamic Azad University Isfahan Branch. This article is an open access article distributed under the terms and conditions of the Creative Commons Attribution 4.0 International (CC BY 4.0)

(<https://creativecommons.org/licenses/by/4.0/>)



1 INTRODUCTION

Brakes are one of the most important components of the elevators. The brake system must be reliable and display unchanging action throughout its use, as it guards the health and life of many people. The term drum brake usually means a brake in which shoes press on the inner/outer surface of the drum. When shoes press on the outside of the drum, it is usually called a clasp brake. Drum brake components include the backing plate, brake drum, shoe, wheel cylinder, and various springs and pins. In operation, the brake shoe of an external contracting brake is tightened around the rotating drum by moving the brake lever. The brake shoe carries the brake lining, which is riveted or glued to the shoe. When the brake is applied, the shoe moves and presses the lining against the inside of the drum. The friction between the lining and drum provides the braking effort. Energy is dissipated as heat. In most elevators (as in this project), the external shoe brake system is applied. Figure 1 shows some external shoe brakes and different pad linings.

In the past two decades, asbestos has become a popular ingredient used to produce brake pads, due to its strength, resistance to heat and fire-proof. Since the 1980s, asbestos has been known as a harmful content and was banned from being used as an ingredient to produce brake pads. Therefore, non-asbestos contents like Kevlar (aramid fiber), glass fiber, and graphite were used to replace the asbestos.

More than 10 different constituents are usually contained in a frictional brake pad. These constituents often contain binder resin, reinforcing fibers, solid lubricants, abrasives, wear resistance, and other friction modifiers. Binder resin and reinforcing fibers used in friction materials have a substantial influence in determining friction characteristics. For improved physical strength and friction performance, the friction materials usually contain two or three different fibers from metallic, ceramic, glass, acrylic, and other fiber. New technologies make it possible to develop materials with various compositions and different proportions and connect them permanently in fully controllable processes. The friction materials are required to provide a stable coefficient of friction and a low wear rate at various operating speeds, pressures, temperatures, and environmental conditions. Furthermore, these materials must also be compatible with the rotor material to reduce its extensive wear, vibration, and noise during braking. Therefore, improving the design of a brake system is a significant practical problem. Shoe brake devices are simple in design and have cost advantages. Ma et al. developed an elevator safety gear braking testing rig based on the disc-pad braking model in principles of energy equivalent and speed equivalent to evaluate the braking behavior of short carbon fiber (SCF) reinforced carbon/carbon (C/C)

composite and Cu-based powder metallurgy (P/M) material [1].

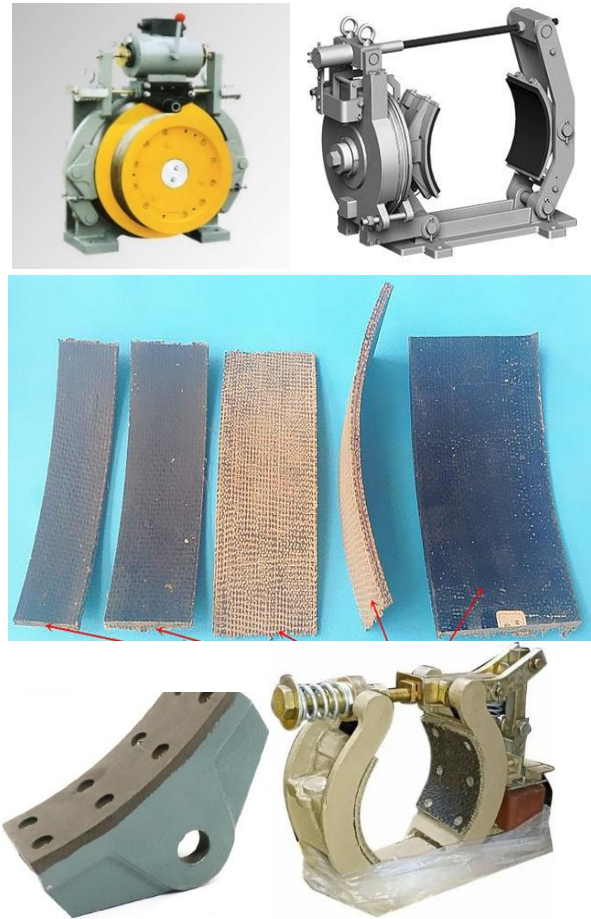

Fig. 1 External shoe brakes and linings.

El-Hija et al. developed Novel C/C–SiC materials for their use as brake pads for high-speed elevators. Under dynamic and stationary conditions, these materials exhibit high thermal shock resistance, high coefficients of friction, and extremely low wear rates. In addition, it has been found that the SiC content of the C/C–SiC materials on the friction surface heavily influences the frictional behaviour [2]. Liew et al. studied the tribological properties difference of potentially newly designed non-commercial brake pad materials with and without asbestos under various speeds and nominal contact pressure. The two fabricated non-commercial asbestos brake pad (ABP) and non-asbestos brake pad (NABP) materials were tested and compared with a Selected Commercial Brake Pad (CMBP) material using a pin-on-disc tribo-test-rig under dry contact conditions. Results showed that friction coefficients for all materials were insensitive to increasing speed and pressure [3]. Borawski published a review article in which he mentioned and investigated the kinds of material for the braking system. His review collects the most important,

and the most unconventional materials used in the production of brake pads, and characterizes their impact on the tribological properties of pads. According to his review, the brake system must be reliable and display unchanging action throughout its use, as it guards the health and life of many people. Properly matched friction pair, a disc and brake pad (in disc brakes), have a great impact on these factors [4]. Applying FEM methods has been very common among researchers [5-8], for example, Riva et al., investigated the possibility to use a Finite Element Analysis (FEA) approach combined with a COF pv-map to compute the global COF of a disc brake system. The local COF is determined from a pv-map for each local sliding velocity and contact pressure determined by the FEA. Results obtained by the simulation are compared with dyno bench test of the same brake system to investigate the validity of the simulation approach. Results show that the simulation is perfectly in line with the experimental measurements in terms of in-stop COF development, but slightly higher with a positive offset for every braking [9]. Günay et al., recommended research and development studies based on finite element modeling and prototype manufacturing in order to produce high-efficiency and safety brake systems compatible with rail system vehicles [10]. Verma et al. focused on the tribological behaviour of a commercial friction pad material dry sliding against a cast iron disc. Pin-on-disc tests were conducted at room temperature under mild wear conditions, as concerns load and rotating speed. The effect of some components of pad material, in particular copper, on the dynamic of formation of tribological layer and wear debris was presented [11]. By applying finishing methods, the surface integrity of manufactured pads can be improved [12-16]. Dmitriev et al. established a model typical for contact situations of automotive brakes based on the method of movable cellular automata [17]. Nouby et al. presented an FE model of the disc brake corner that includes the wheel hub and steering knuckle. Their model was an extension of earlier FE disc brake models. Experimental modal analysis of the disc brake system was initially used to validate the FE model [18]. By appearing advanced manufacturing methods such as modern machining, new pads with advanced materials have been manufactured [19-23]. Yevtushenko et al. carried out Finite Element Analysis (FEA) of a single braking process for the axisymmetric heat conduction problem of friction in a pad/disc brake system in the present article. Two materials of the pad FC-16L (retinax A) and FMC-11 (metal ceramic) and one material of the disc (cast iron) were analyzed in their study [24]. Talati et al. extracted the governing heat Equations for the disk and the pad in the form of transient heat Equations with heat generation that is dependent on time and space. The problem is solved analytically using Green's function approach [25]. Yevtushenko et al. studied the influence

of nine various (experimental and theoretical) formulas for heat partition ratio on temperature in a pad/ disc tribosystem. The real dimensions, operating conditions, and thermophysical properties of materials of two different disc brake systems were adopted for the finite element analysis [26]. Shanker reviewed different braking methods and procedures used in the study of automotive braking system. It covers types of braking systems, material properties and different types of materials used in the manufacturing of especially disc brakes [27]. Lu et al. tested a brake pad material used in a popular, commercially available vehicle that consisted of steel wool, iron powder, graphite, coke, styrene-butadiene rubber, MgO, BaSO₄, and phenolic resin with the friction assessment and screening test. Their material exhibited an average friction coefficient of 0.419 and a low total wear of 6.25wt% [28].

In this study, the effects of the brake pad materials on the braking system performance are investigated via FEM simulation. In this case, some different materials of brake pads including modern materials including Composite Carbon fiber reinforced, Composite Epoxy SMC and SiC (silicon carbide) are selected, then, their properties are extracted from their manufacturer catalogues as well as related papers. The brake system is modelled in a CAD software (SolidWorks) and the FEM simulation is performed in Ansys software. The performance of the brake system is compared by different pad materials and the proper pad material is introduced.

2 MATERIALS AND METHODS

In this study, the simulations are performed in Ansys software 2022. The initial model was designed via SolidWorks software and then was imported in the Ansys software according to "Fig. 2". The model contains braking system parts including brake pads, shaft, lever, pulley and link.

In this project, non-conventional (modern) materials were used for the brake pads including Composite Carbon fiber reinforced, Composite Epoxy SMC and SiC (silicon carbide). These materials were selected due to their growing applications in the braking pad. The properties of selected pads materials are demonstrated at the "Table 1".

To analyze this problem in Ansys, three modules can be used: rigid dynamic, static structural and transient structural. In the present study, the third module - transient structural- has been applied. Transient structural module is proper for problems with high deflection as well as high velocity. This module also has a higher analysis rate. In the next step, the materials should be defined. The shaft material was defined as a structural steel with a yield stress equal to 25 MPa.

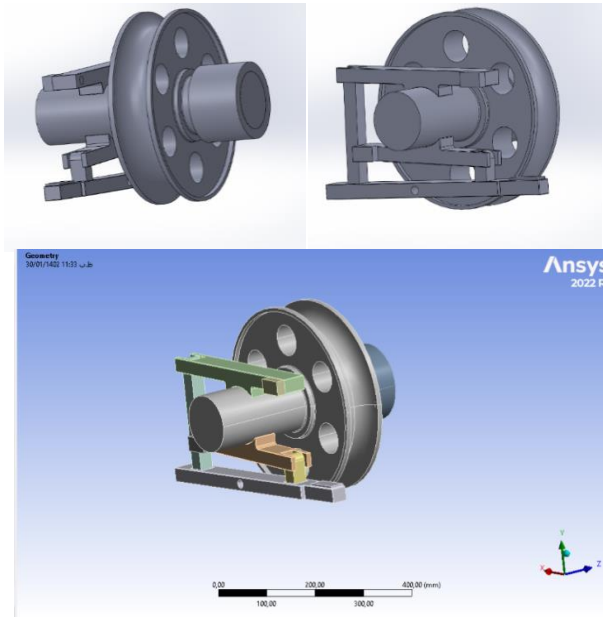

Fig. 2 Initial model of braking system.

Table 1 Properties of Composite Carbon fiber reinforced, Composite Epoxy SMC and SiC

Materials Properties	SMC	Carbon fiber	SiC
Density	1.47e-6 kg/mm ³	1.7e-6 kg/mm ³	3.1 kg/mm ³
Young's Modulus	57810 MPa	94870 MPa	410000 Mpa
Poisson's Ratio	0.303	0.319	0.14
Bulk Modulus	49033 MPa	87745 MPa	3900 Mpa
Shear Modulus	22175 MPa	35941 MPa	55000 MPa
Ultimate Strength	261 MPa	503 MPa	1020 MPa
Yield Strength	249 MPa	503 MPa	1015 MPa
Thermal Conductivity	0.00046 W/mm.C	0.026 W/mm.C	0.12 W/mm.C

In the next step, connections among parts in the Connection module were defined. In the other world, the boundary conditions were set. According to “Fig. 3”, the holder is fixed and the shaft can rotate in the centre of it. In addition, the motion of the pad is defined. In this way, when forces are imposed on the lever, the movement of the lever leads to the movement of the pad and contact of the pad to the shaft.

In the Contact module, the action and reaction of parts when colliding with each other are defined. In this section, if no contact is defined between two parts, these two parts pass through each other. Therefore, three kinds of contacts can be defined among parts: frictional, sticking, and no frictional. In the present project, the frictional contact between the shaft and pads was defined.

It is worth mentioning that the Coefficient of Friction CoF is not constant and depends on the velocity of the shaft and the temperature. Precisely defining the CoF is not easy, and many surveys have been conducted to measure it. For example, “Fig. 4” shows the results of a study in which the CoF was measured in different conditions [22]. Anyway, in the present study, the CoF is presumed constant for each material and independent of speed.

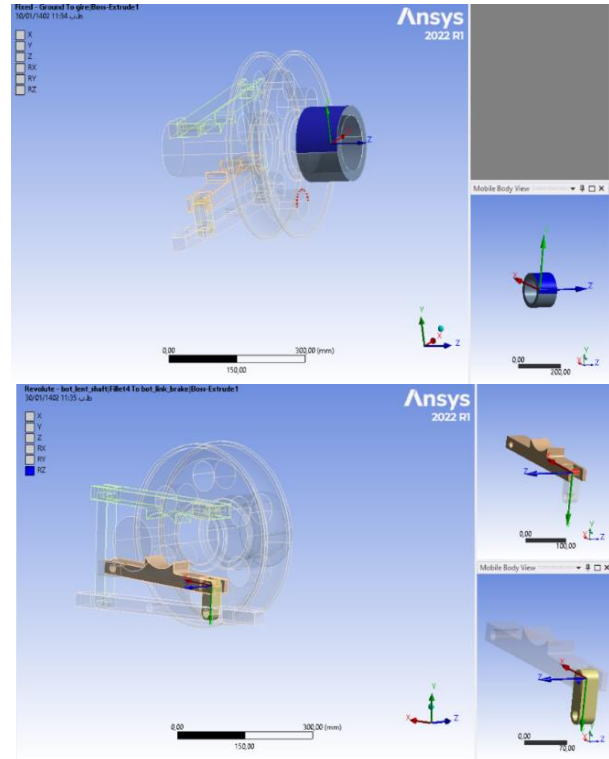

Fig. 3 Boundary conditions.

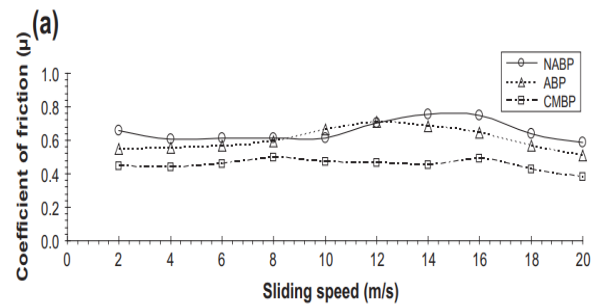

Fig. 4 Coefficient of friction versus speed in some materials [22].

The Meshing is defined in the Mesh module. According to “Fig. 5”, meshing was performed between the shaft and the pad’s halves. Here, due to the significance of the shaft and pads, these parts have fine mesh sizes; despite the other parts such as the pulley and links which have larger mesh sizes. If the mesh size of the whole of the

mechanism is identical, the run time increases dramatically. The mesh size is 15mm and it is a 2D (surface mesh) type. In addition, the mesh control was applied to investigate the convergence of the results.

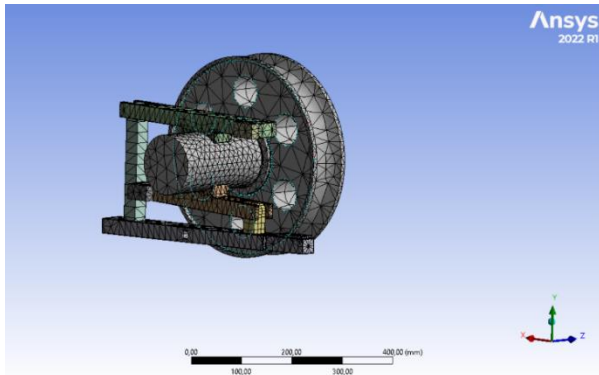

Fig. 5 Meshed part.

3 RESULTS & DISCUSSIONS

In this study, the effects of the brake pad materials on the braking system performance were investigated via FEM. The results are as follows. According to “Fig. 6”, the whole braking system was stress analyzed and, the maximum stress imposed on brake pads and the shaft was obtained.

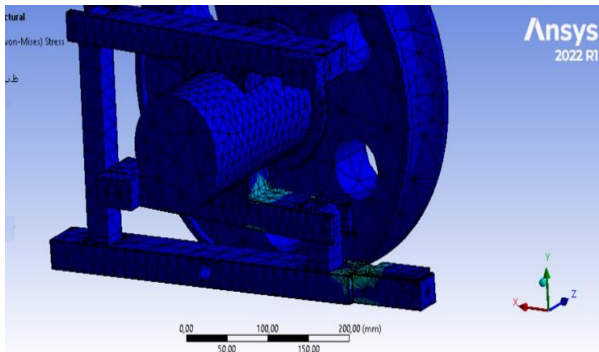

Fig. 6 Stress analyzed of braking system

Figure 7 shows the stress on the shaft for the carbon fiber pad’s material. As it is obvious, the maximum stress on the shaft with this pad’s material is 84MPa. Figure 8 demonstrates the stress on the shaft for the SMC pad’s material. As it is clear, the maximum stress on the shaft with this pad’s material is 54MPa which is lower than carbon fiber. The maximum stress on the pads with carbon fiber pad material is about 455MPa which is shown in “Fig. 9”. In addition, the maximum stress on the pads with SMC pad material is about 301MPa (“Fig. 10”). The stresses on pads are very high and result in an

increase in the temperature of pads and consequently increase in their abrasion.

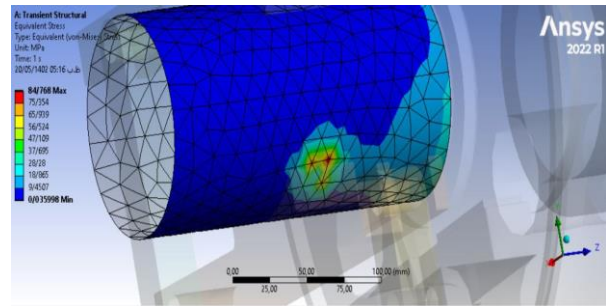

Fig. 7 Stress on the shaft (carbon fiber pad).

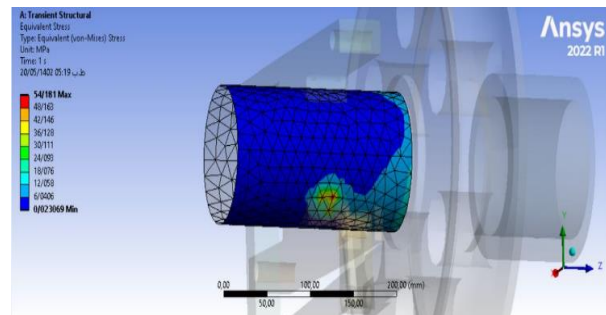

Fig. 8 Stress on the shaft (SMC pad).

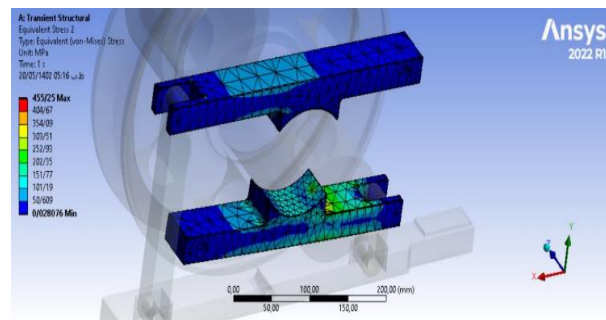

Fig. 9 Stress on the pads (carbon fiber pad)

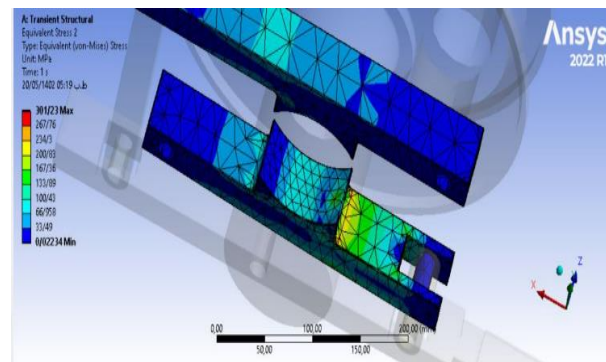

Fig. 10 Stress on the pads (SMC pad).

The strain imposed on the braking system (pads, links and levers) was obtained as well and is shown in “Fig. 11” (for carbon fiber pad’s material) and in “Fig. 12” (SMC pad’s material). The maximum strain was 0.004 mm/mm for both materials which implies the stiffness of the braking system.

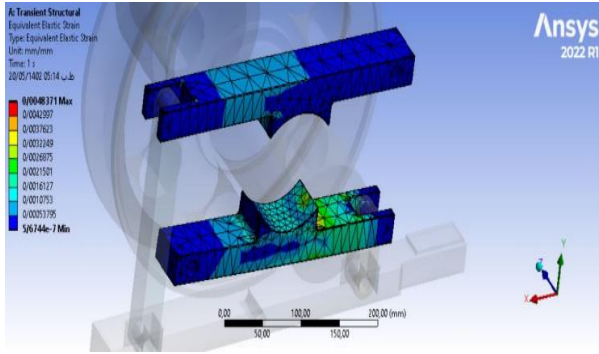

Fig. 11 Strain of the pads and levers (carbon fiber pad).

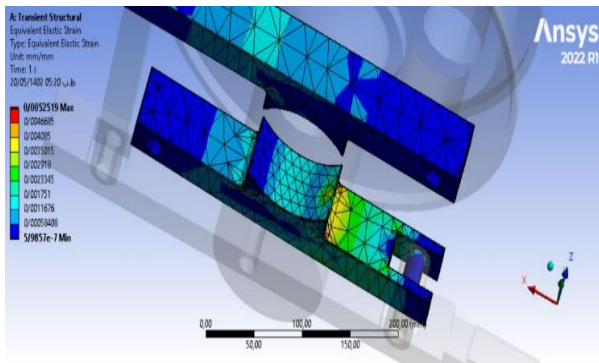

Fig. 12 Strain of the pads and levers (SMC pad).

In “Fig. 13”, the velocity contour and in “Fig. 14”, the acceleration contour are demonstrated. The acceleration and velocity of the rotating elements further from the center are more than those located at the center of rotation. In addition, in “Fig. 15”, the total displacement of the elements that occurred during the braking action is shown. The total displacement of the external elements of the pulley is maximum and equals 30cm.

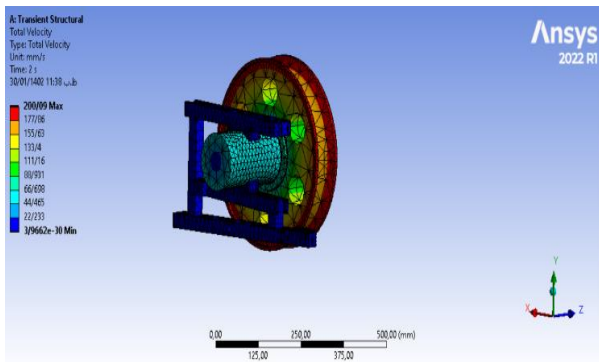

Fig. 13 Velocity contour.

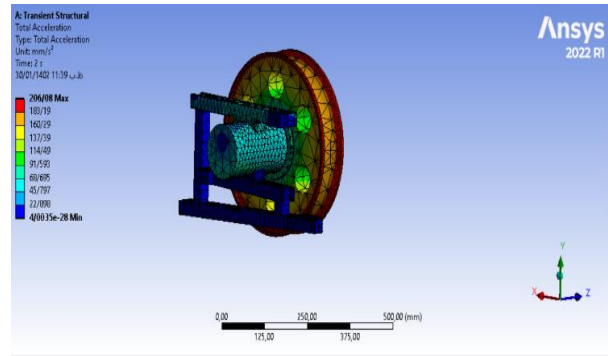

Fig. 14 Acceleration contour.

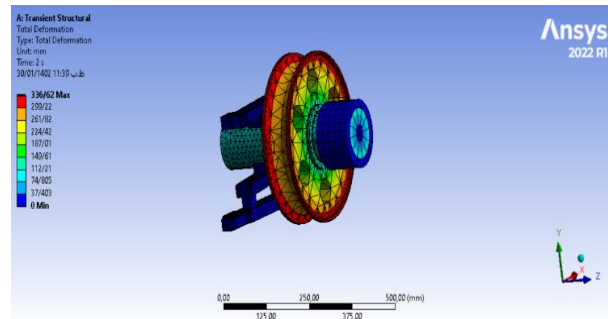

Fig. 15 Total displacement.

In “Fig. 16”, the diagram of the negative acceleration of the braking system for fiber carbon pad material is shown. according to this diagram, the system stops after 0.5s, which is acceptable. As it was mentioned before, the initial rotary speed of the shaft was 10m/s. In addition, as “Fig. 17” shows, the stresses imposed on the system increase dramatically during the braking period.

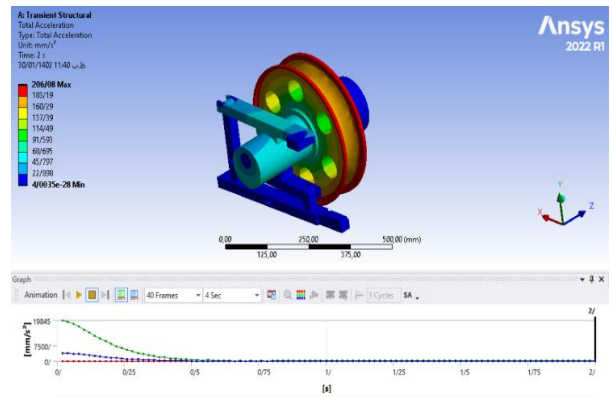

Fig. 16 Negative acceleration of the braking system for fiber carbon pad.

In the “Fig. 18”, the performance of three pad materials is compared. To investigate the performance of the pad material, the negative acceleration, negative velocity, and the increase in stress during the braking period are analyzed.

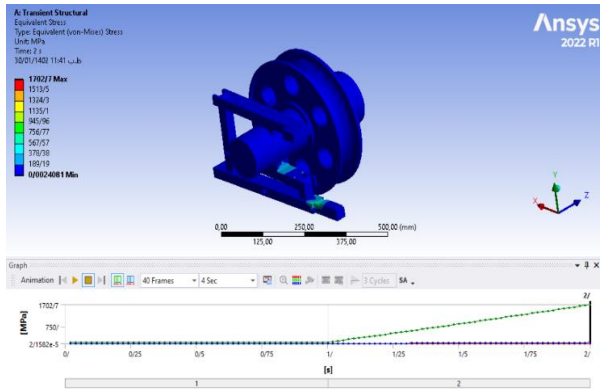

Fig. 17 Stresses imposed on the system during braking period for fiber carbon pad.

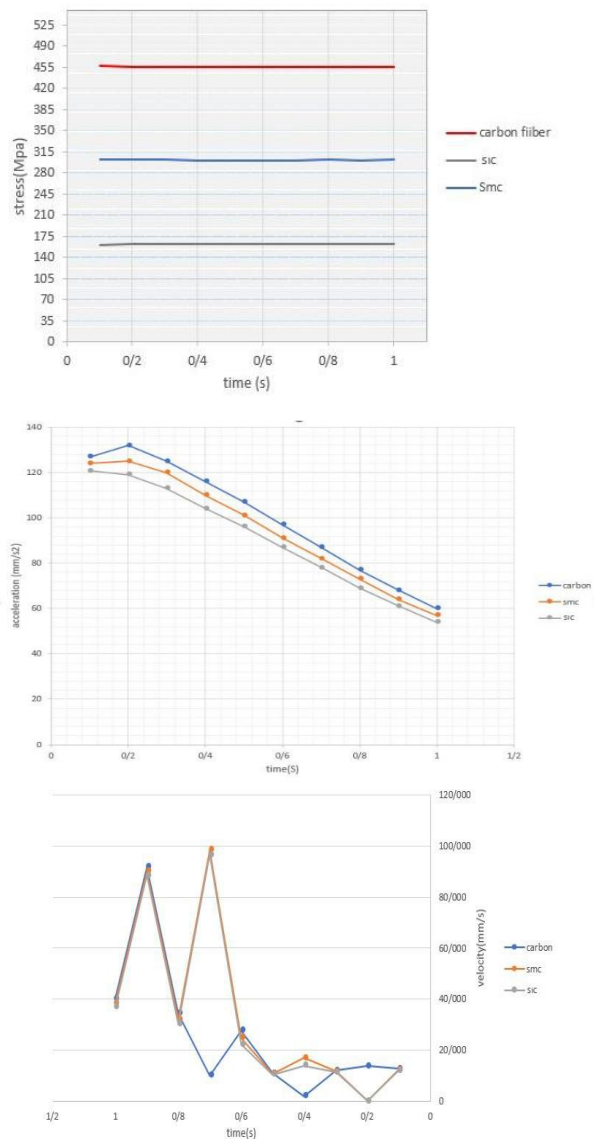

Fig. 18 Comparison performance of three pad materials (Stress, Velocity and Acceleration).

Accordingly, the performance of SiC (silicon carbide) is better than two other materials. In the braking system with SiC, the required time for stoppage of the system is lower than two other materials. In addition, the performance of SMC is better than Composite Carbon fiber reinforced.

4 CONCLUSIONS

In this study, the effects of the brake pad materials on the braking system performance were investigated via FEM simulation. The following conclusions can be drawn from the present work:

- The maximum stress on the shaft with carbon fiber pad material was 84MPa.
- The maximum stress on the shaft with the SMC pad material was 54MPa which was lower than carbon fiber.
- The maximum stress on the pads with carbon fiber pad material was about 455MPa.
- The maximum stress on the pads with SMC pad material was about 301MPa.
- The stresses on pads were very high resulting in an increase in the temperature of pads and consequently increase in their abrasion.
- The strain imposed on the braking system (pads, links, and levers) was obtained as well.
- The maximum strain was approximately 0.004 mm/mm for both materials which implies the stiffness of the braking system.

5 ACKNOWLEDGEMENTS

We are grateful to the Research Council of Shahid Chamran University of Ahvaz for financial support (SCU.EM1402.39184).

REFERENCES

- [1] Ma, X., et al., Experimental Evaluation of Braking Pad Materials Used for High-Speed Elevator, *Wear*, Vol. 477, 2021, pp. 203872.
- [2] El-Hija, H. A., Krenkel, W., and Hugel, S., Development of C/C–SiC Brake Pads for High-Performance Elevators. *International Journal of Applied Ceramic Technology*, Vol. 2, 2005, pp. 105-113.
- [3] Liew, K., Nirmal, U., Frictional Performance Evaluation of Newly Designed Brake Pad Materials, *Materials & Design*, Vol. 48, 2013, pp. 25-33.
- [4] Borawski, A., Conventional and Unconventional Materials Used in The Production of Brake Pads–Review, *Science and Engineering of Composite Materials*, Vol. 27, No. 1, 2020, pp. 374-396.

- [5] Mahdiah, M. S., et al., A Study on Stamping of Airliner's Tail Connector Part Through FEM Simulation, *Journal of Simulation and Analysis of Novel Technologies in Mechanical Engineering*, Vol. 15, No. 3, 2023, pp. 5-13.
- [6] Mahdiah, M. S., Esteki, M. R., Feasibility Investigation of Hydroforming of Dental Drill Body by FEM Simulation, *Journal of Modern Processes in Manufacturing and Production*, Vol. 11, No. 2, 2022, pp. 71-83.
- [7] Mahdiah, M. S., Monjezi, A., Investigation of an Innovative Cleaning Method for the Vertical Oil Storage Tank by FEM Simulation, *Iranian Journal of Materials Forming*, 2022.
- [8] Mahdiah, M. S., Bakhshi Zadeh, M., and Zare Reisabadi, A., Improving Surface Roughness in Barrel Finishing Process Using Supervised Machine Learning, *Journal of Simulation and Analysis of Novel Technologies in Mechanical Engineering*, Vol. 15, No. 2, 2023, pp. 5-15.
- [9] Riva, G., Varriale, F., and Wahlström, J., A Finite Element Analysis (FEA) Approach to Simulate the Coefficient of Friction of A Brake System Starting from Material Friction Characterization, *Friction*, Vol. 9, No. 1, 2021, pp. 191-200.
- [10] Günay, M., Korkmaz, M. E., and Özmen, R., An Investigation on Braking Systems Used in Railway Vehicles, *Engineering Science and Technology, An International Journal*, Vol. 23, No. 2, 2020, pp. 421-431.
- [11] Verma, P. C., et al., Braking Pad-Disc System: Wear Mechanisms and Formation of Wear Fragments, *Wear*, Vol. 322, 2015, pp. 251-258.
- [12] Saraeian, P., et al., Influence of Vibratory Finishing Process by Incorporating Abrasive Ceramics and Glassy Materials on Surface Roughness of CK45 Steel, *ADMT Journal*, Vol. 9, No. 4, 2016, pp. 1-6.
- [13] Vakili Sohrforozani, A., et al., A Study of Abrasive Media Effect on Deburring in Barrel Finishing Process, *Journal of Modern Processes in Manufacturing and Production*, Vol. 8, No. 3, 2019, pp. 27-39.
- [14] Mahdiah, M. S., The Surface Integrity of Ultra-Fine Grain Steel, Electrical Discharge Machined Using Iso-Pulse and Resistance-Capacitance-Type Generator, *Proceedings of the Institution of Mechanical Engineers, Part L: Journal of Materials: Design and Applications*, Vol. 234, No. 4, 2020, pp. 564-573.
- [15] Vakili Sohrforozani, A., et al., Effects of Abrasive Media on Surface Roughness in Barrel Finishing Process, *ADMT Journal*, Vol. 13, No. 3, 2020, pp. 75-82.
- [16] Mahdiah, M. S., Improving Surface Integrity of Electrical Discharge Machined Ultra-Fined Grain Al-2017 by Applying RC-Type Generator, *Proceedings of the Institution of Mechanical Engineers, Part E: Journal of Process Mechanical Engineering*, 2023, pp. 09544089231202329.
- [17] Dmitriev, A., Österle, W., and Kloß, H., Numerical Simulation of Typical Contact Situations of Brake Friction Materials, *Tribology International*, Vol. 41, No. 1, 2008, pp. 1-8.
- [18] Nouby, M., Srinivasan, K., Simulation of the Structural Modifications of A Disc Brake System to Reduce Brake Squeal, *Proceedings of the Institution of Mechanical Engineers, Part D: Journal of Automobile Engineering*, Vol. 225, No. 5, 2011, pp. 653-672.
- [19] Mahdiah, M. S., Mahdavejad, R., Comparative Study on Electrical Discharge Machining of Ultrafine-Grain Al, Cu, and Steel, *Metallurgical and Materials Transactions A*, Vol. 47, No. 12, 2016, pp. 6237-6247.
- [20] Mahdiah, M. S., Mahdavejad, R. A., A Study of Stored Energy in Ultra-Fined Grained Aluminum Machined by Electrical Discharge Machining, *Proceedings of the Institution of Mechanical Engineers, Part C: Journal of Mechanical Engineering Science*, Vol. 231, No. 23, 2017, pp. 4470-4478.
- [21] Mahdiah, M. S., Mahdavejad, R., Recast Layer and Micro-Cracks in Electrical Discharge Machining of Ultra-Fine-Grained Aluminum, *Proceedings of the Institution of Mechanical Engineers, Part B: Journal of Engineering Manufacture*, Vol. 232, No. 3, 2018, pp. 428-437.
- [22] Mahdiah, M. S., Zare-Reisabadi, S., Effects of Electro-Discharge Machining Process on Ultra-Fined Grain Copper, *Proceedings of the Institution of Mechanical Engineers, Part C: Journal of Mechanical Engineering Science*, Vol. 233, No. 15, 2019, pp. 5341-5349.
- [23] Mahdiah, M. S., Recast Layer and Heat-Affected Zone Structure of Ultra-Fined Grained Low-Carbon Steel Machined by Electrical Discharge Machining, *Proceedings of the Institution of Mechanical Engineers, Part B: Journal of Engineering Manufacture*, Vol. 234, No. 5, 2020, pp. 933-944.
- [24] Yevtushenko, A., Grzes, P., Axisymmetric FEA of Temperature in A Pad/Disc Brake System at Temperature-Dependent Coefficients of Friction and Wear, *International Communications in Heat and Mass Transfer*, Vol. 39, No. 8, 2012, pp. 1045-1053.
- [25] Talati, F., Jalalifar, S., Analysis of Heat Conduction in A Disk Brake System, *Heat and Mass Transfer*, Vol. 45, No. 8, 2009, pp. 1047-1059.
- [26] Yevtushenko, A., Grzes, P., Finite Element Analysis of Heat Partition in A Pad/Disc Brake System, *Numerical Heat Transfer, Part A: Applications*, Vol. 59, No. 7, 2011, pp. 521-542.
- [27] Shanker, P. S., A Review on Properties of Conventional and Metal Matrix Composite Materials in Manufacturing of Disc Brake, *Materials Today: Proceedings*, Vol. 5, No. 2, 2018, pp. 5864-5869.
- [28] Lu, Y., Tang, C. F., and Wright, M. A., Optimization of a Commercial Brake Pad Formulation, *Journal of Applied Polymer Science*, Vol. 84, No. 13, 2002, pp. 2498-2504.