

Investigation of Process Parameters on Hot Ring Rolling by Coupled Thermo-Mechanical 3D-FEA

Amir Hossein Gheisari*

Department of Mechanical Engineering,
Isfahan University of Technology, Isfahan, Iran
E-mail: a.Gheisari@me.iut.ac.ir

*Corresponding author

Mohammad Reza Forouzan

Department of Mechanical Engineering,
Isfahan University of Technology, Isfahan, Iran
E-mail: Forouzan@cc.iut.ac.ir

Abdol Ali Maracy

Department of Mechanical Engineering,
Malek-ashtar University of Technology, Shahinshar, Iran
E-mail: A_maracy@mut-es.ac.ir

Received 31 May 2011; Revised 21 July 2011; Accepted 19 August 2011

Abstract: Hot rolling of a large ring of titanium alloy (LRT) is a highly nonlinear incremental forming process with coupled mechanical and thermal behaviors (MTBs) which significantly affect microstructure and properties of the ring. The feed rate of idle roll and the rotational speed of driver roll have major effects on ovality of the ring. In this paper, the effects of these parameters on the ovality of the ring have been investigated by a coupled thermo-mechanical 3D-FEA. The results show that the ovality of ring blank decreases with the increase of the rotational speed of driver roll or the decrease of the feed rate of idle roll. The results obtained can provide a guide for forming parameters optimization.

Keywords: Coupled Thermo-Mechanical FE Model, Hot Ring Rolling, Ovality Distribution

Reference: Gheisari, A. H., Forouzan, M. R., Maracy, A. A., (2011) 'Investigation of Process Parameters on Hot Ring Rolling by Coupled Thermo-Mechanical 3D-FEA', Int J Advanced Design and Manufacturing Technology, Vol. 4/ No. 4, pp. 33-38.

Biographical notes: **A. H. Gheisari** is Graduate Student of Mechanical Engineering, Isfahan University of Technology. He received his B.Sc from Kashan University, Iran. His current research focuses on Metal Forming Process Simulation and Optimization. **M. R. Forouzan** is Associate Professor of Mechanical Engineering at the Isfahan University of Technology, Iran. He received his PhD in Mechanical Engineering from Isfahan University of Technology. His current research focuses on Metal Forming and Metal Fracture Processes. **A. A. Maracy** is Assistant Professor of Mechanical Engineering at the Malek-ashtar University of Technology, Iran. He received his PhD in Mechanical and Manufacturing Engineering from Birmingham University, England, 1992. His current research focuses on Ring Rolling, Forging and Extrusion Processes.

1 INTRODUCTION

Hot ring rolling (HRR) is an advanced incremental forming process with coupled thermo-mechanical effect. In recent years, with the rapidly increasing demand of aviation and aerospace industries for high-quality large seamless rings of high-strength material like titanium alloy, hot ring rolling has become a preferred processing method for manufacturing such rings due to its advantages such as a considerable saving of energy and material costs, high quality, high efficiency and low noise.

In ring rolling, a heated doughnut-shaped blank, preformed on a press or forging hammer, is placed over a mandrel of slightly smaller diameter than the hole in the blank. The roll gap between the mandrel (undriven) and a larger-diameter driver main roll is progressively reduced. Friction between the main roll and the ring causes the ring to rotate, and the ring in turn rotates the bearing-mounted mandrel. As the radial cross-section of the ring decrease, circumferential extrusion occurs in the direction of ring rotation, and the ring diameter grows.

Applications for seamless rolled rings include antifriction bearing races, gear rims, slewing rings, railroal wheel bearings, commutator rings, rotating and nonrotating rings for jet engines and other aerospace applications, nuclear reactor component, bevel ring gears, and flanges of all kinds (including weld-neck flanges) [1].

Rolling processes especially hot ring rolling is affected by many parameters. Therefore, the development of accurate coupled thermo-mechanical finite-element model for hot ring rolling is of major commercial and technological interests as they provide an essential understanding of an insight into how these parameters affect the ring product.

Due to complexity of HRR process, by now, most of the research work has been focused on description, modeling and simulation of the process using finite element method [2,3], but lack of considering influence of process parameters on deformation and ovality of the ring. The material plastic deformation behavior were discussed [4,5], but the object was cold ring rolling, and coupled thermo-mechanical was not concerned. Although some work has been done on geometrical distortion of rings during cooling after rolling [6], and guide rollers and conical rollers's parameters optimization [7], the work related to ring ovality and process parameter effect is insufficient, due to the importance of ovality for forming quality.

In this study, a coupled thermo-mechanical and 3D rigid-plastic FE model for hot ring rolling of titanium alloy large rings is established. Then base on the stable forming condition of the ring rolling process and comprehensive numerical simulation, the effects of process parameters, including rotational speed of driver roll and feed rate of idle roll were investigated by 3D-coupled thermo-mechanical FE simulation. The results will provide a guide for process parameters optimization and quality control of the hot ring rolling process.

2 3D COUPLED THERMO-MECHANICAL FE MODEL

Figure. 1 illustrates the 3D coupled thermo-mechanical FE model developed based on the FE explicit code ABAQUS for simulation of the hot ring rolling of titanium alloy large rings with rectangular cross-section. The model is composed of driver roll, mandrel roll and ring. According to the direct effect of guide roll's movement on ring's roundness, these rolls has been deleted from simulation to particularly investigate the effect of referred parameters. To avoid ring's distortion in the absence of guide rolls, internal and external viscous pressure has been exert on the ring [8]. Comparing with the ring, the variation of the deformation of the rolls are so small that the rolls are treated as analytical rigid bodies that lead to cheaper computational costs and less noisy contact. The coupled thermo-mechanical hexahedrally elements with eight nodes are selected to discretize the ring uniformity.

Rigid-plastic finite element method is adopted to improve the computational accuracy. Contact pairs are defined between the ring and driver roll as well as idle roll to describe the dynamic contact. There exist friction and contact heat conduction at the interface of each contact pairs. Constant shearing friction model is used to describe friction between the ring and rolls. The friction coefficient between ring and the driver roll is assume higher than the idle roll for more uniform deformation, the cause will be presented in future works.

In the FE model, an adaptive mesh domain is created for the entire ring. This makes it possible to maintain a high-quality mesh throughout the analysis.

Mass scaling technique are adopted to speed up the computation. Tekkaya indicated that mass scaling, i.e, artificially increasing the density of material, is a preferred speed-up method if the material is strain rate sensitive or the process involve thermo-mechanical

phenomena [9]. An appropriate mass scaling factor should not result in erroneous solutions from virtual inertial effect. ABAQUS suggested a general rule to obtain an appropriate mass scaling factor [8]. According to this rule, the kinetic energy of deforming material should not exceed a small fraction (typically 5-10%) of its internal energy throughout most of the process.

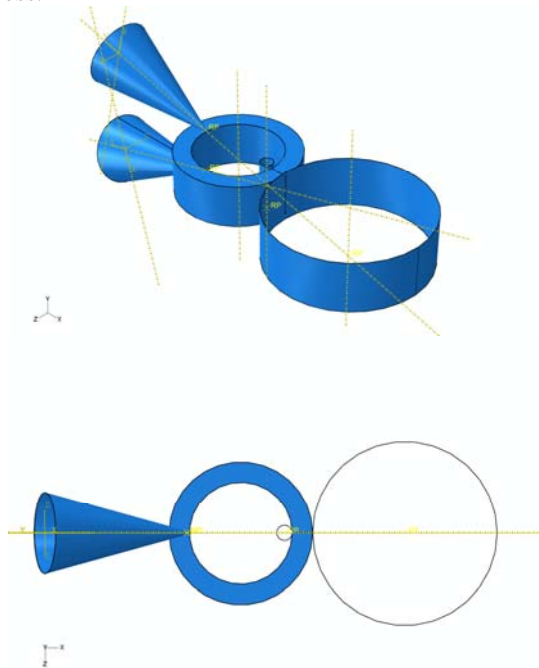

Fig. 1 3D coupled Thermo-mechanical FE model of Hot Ring Rolling of rectangular cross-section ring

3 MODEL VALIDATION

The accuracy of the FE model was tested based on the experimental results acquired by Mamalis [10]. A ring rolling process of a profiled ring was tested. The experimental data are shown in Table 1.

Table 1 Experimental data

Ring's material	Aluminium alloy HE30
Driver roll rotational speed	31 rev/min
Idle roll feed rate	0.019 in/rev

For the numerical simulation, an aluminium alloy HE30 (the same used for the experimental results) was considered. Under the mentioned hypothesis in Table 1, the simulation of the ring rolling process was executed. In Figs. 2 and 3 the dimension of the rolled ring at the end of the simulation and the comparison between the

simulated and experimental rings are respectively reported.

As can be seen the FE model can predict the final dimension of the ring with a good accuracy. So the numerical results are able to predict the experimental values with a good accuracy also during the whole process.

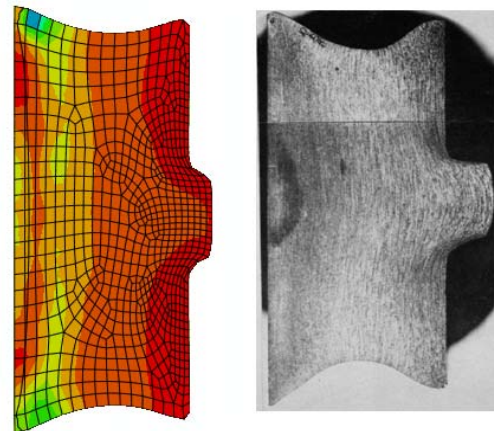

Fig. 2 Comparison between the simulated and experimental ring

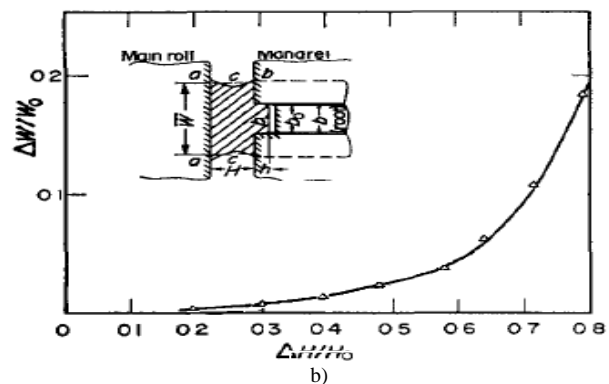
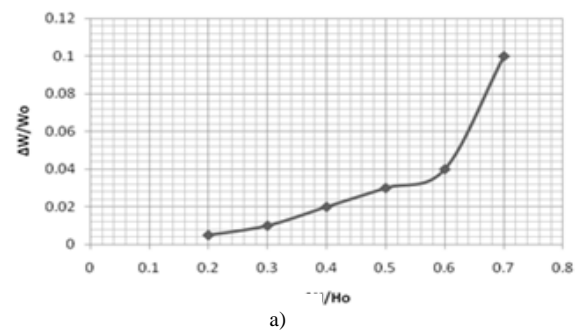

Fig. 3 Comparison between the a) simulated and b) experimental spread vs total reduction in wall thickness, center spread

In this simulation, the mass of the entire ring is scaled to 100 times the actual mass to obtain an economical solution.

Figure. 4 shows the histories of the internal and kinetic energies of the ring. It can be seen that the two are smooth; the kinetic energy increases to a certain value at the biting stage, and then remain approximately fixed, which indicates the start of the stable forming stage. In the view of the above rule, a satisfactory quasi-static solution has been obtained.

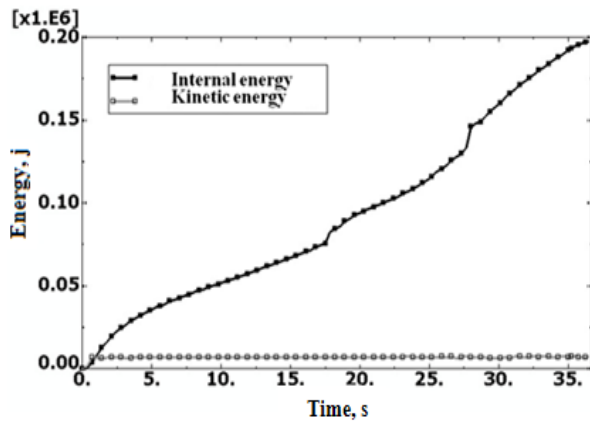

Fig. 4 Histories of internal and kinetic energies

4 SIMULATION CONDITIONS

The material of ring is Ti-6Al-4V and its thermo-mechanical properties are shown in Table 2.

Table 2 Thermo – mechanical properties of Ti-6Al-4V

Properties	Value
Density	4370 kg/m ³
Modulus of elasticity	113.8 GPa
Poisson's ratio	0.342
Specific heat capacity	0.5283 J/gC
Thermal conductivity	6.7 W/mK
Initial temperature of ring blank	1050 °C
Initial temperature of rolls	30 °C
Ambient temperature	30 °C
Emissivity	0.7
Driver roll-ring blank friction Coefficient	0.5
Idle roll-Ring blank friction Coefficient	0.3

In the HRR, most of the properties are temperature-dependent and changes with the progress of the process so the values of these parameters in some point of

temperatures are defined for the software [11]. The simulation conditions are summarized in Table 3.

Table 3 Simulation conditions

Properties	Value
Radius of drive roll (inch)	9
Radius of mandrel roll (inch)	2.75
Outer radius of ring blank (inch)	5
Inner radius of ring blank (inch)	1
Axial height of ring blank (inch)	1

In this work, two parameters are considered: driver roll rotational speed n and feed rate of idle roll v . The calculation conditions for simulation are divided into two groups as shown in Table 4.

Table 4 Process parameters

Case	n (rad/sec)	v (mm/sec)
Case 1	1, 2, 3, 4, 5, 6, 12	0.3
Case 2	3	0.1, 0.2, 0.3, 0.4, 0.5, 0.6

5 RESULTS AND DISCUSSION

Based on the FE model established, the HRR process was thoroughly simulated and analysed, then the material flow and ovality of the ring under different forming conditions and the effects of process parameters on them were investigated.

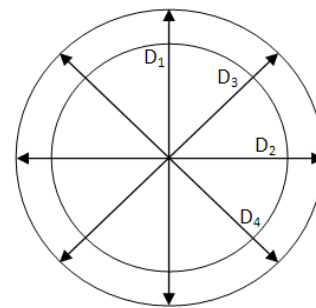

Fig. 5 Ring's roundness parameters

Here, a parameter (O) is defined to describe the roundness of the ring as follows:

$$O = \frac{|D_1 - D_2| + |D_3 - D_4|}{2} \quad (1)$$

Where D_1, D_2, D_3, D_4 is shown in Fig. 5. Increasing this parameter represent decreasing of ring's roundness.

6 EFFECT OF DRIVER ROLL ROTATIONAL SPEED

Under simulation Case 1, effects of driver roll rotational speed n on the process and ovality of ring in HRR were discussed.

The results show that with the driver roll rotational speed n increasing, the parameter O decrease, and the roundness of the ring increase (Fig. 6). While for further increasing of n , roundness of the ring tends to decrease as shown in Fig. 7.

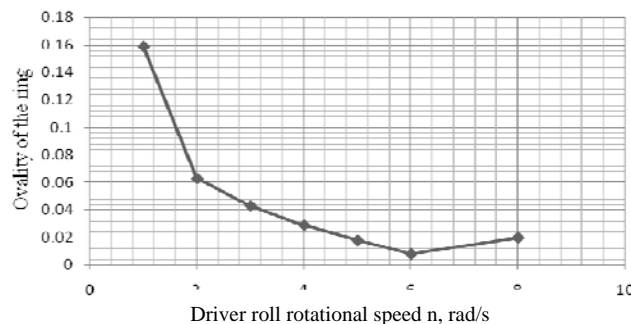

Fig. 6 Effect of n on ovality of the ring

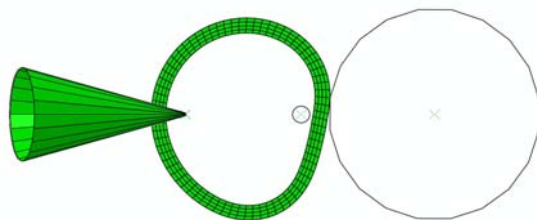

Fig. 7 Deformed ring in high rotational speed of driver roll

7 EFFECT OF FEED RATE OF IDLE ROLL

Under simulation Case 2, effect of feed rate of idle roll v on the process and ovality of ring in HRR were discussed.

With the feed rate of idle roll v increasing, the parameter O increase, and the roundness of the ring

decrease (Fig. 8). Further increasing of v results to ring defect because of excessive penetration of idle roll into the ring (Fig. 9).

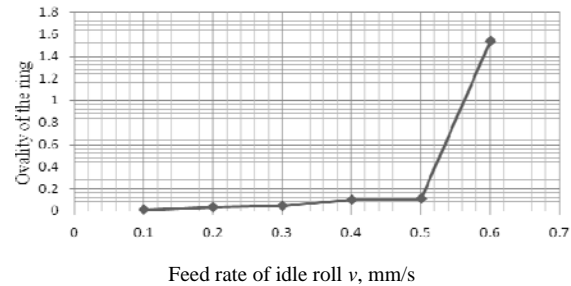

Fig. 8 Effect of v on ovality of the ring

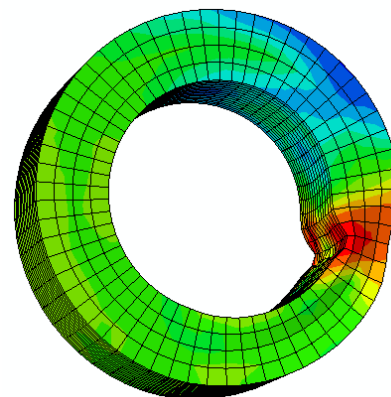

Fig. 9 Defected ring in high feed rate of idle roll

8 CONCLUSION

- 1) A 3D-FE model under coupled thermo-mechanical effects of hot ring rolling process has been developed based on ABAQUS code.
- 2) The influence of main process parameters on ring deformation and roundness has been open out in hot ring rolling process, including rotational speed of driver roll and feed rate of idle roll.

REFERENCES

- [1] Semiatin, S. L., ASM Handbook, Forming and Forging, ASM International, Vol. 14, 1993, Ninth Ed, pp. 224.
- [2] Song, J. L., Dowson, A. L., Jacobs, M. H., Brooks, J. and Beden, I., "Coupled Thermo-Mechanical Finite-Element Modeling of Hot Ring Rolling Process," Journal of Materials Processing Technology, Vol. 121, 2002, pp. 332-340.
- [3] Wang, Min., Yang, He., Sun, Zhi-Chao., Gup and Liang-Gang., "Dynamic Explicit FE Modeling of Hot Ring

- Rolling Process,” *Trans Nonferrous Met Soc China*, Vol. 16, No. 6, 2006, pp. 1274-1280.
- [4] Guo, Liang-Gang., Yang, He. and Zhan, Mei., “Research on Plastic Deformation Behavior in Cold Ring Rolling by FEM Numerical Simulation,” *Modeling and Simulation in Material Science and Engineering*, Vol. 13, No. 7, 2005, pp. 1029-1046.
- [5] Li, Lanyun., Yang, He., Guo, Liang-Gang. and Sun, Zhi-Chao., “Research on Interactive Influence of Parameters on T-Shaped Cold Ring-Rolling by 3d-FE Numerical Simulation,” *Journal of Mechanical Science and Technology*, Vol. 21, No. 10, 2007, pp. 1541-1547.
- [6] Casotto, S., Pascon, F., Habraken, A. M. and Bruschi, H., “Thermo-Mechanical-Metallurgical Model to Predict Geometrical Distortion of Rings During Cooling Phase after Ring Rolling Operations,” *International Journal of Machine Tools and Manufacturing*, Vol. 45, 2005, pp. 657-664.
- [7] Wang, Z. W., Fan, J. P., Hu, D. P., Tang, C. Y. and Tsui, C. P., “Complete Modeling and Parameter Optimization for Virtual Ring Rolling,” *International Journal of Mechanical Science*, Vol. 52, 2010, pp. 1325-1333.
- [8] ABAQUS User’s Manual, Ver. 6.9, Dassault Systemes Simulia Corp, USA, 2009.
- [9] Tekkaya, A. E., “State-of-the-Art of Simulation of Sheet Metal Forming,” *Journal of Material Processing Technology*, Vol. 103, 2000, pp. 14-22.
- [10] Mamalis, A. G., Hawkyard, J. B. and Jhonson, W., “Spread and Flow Patterns in Ring Rolling,” *Int J. Mech. Sci*, Vol. 18, 1976, pp. 11-16.
- [11] DEFORM-3D, Ver. 6.1.3, SFTC Corp, 2009.