

# Survey and Effects of Manufacture and Assembly Errors on the Output Error of Globoidal Cam Mechanisms

Hassan Gheisari<sup>1\*</sup>, Ebrahim Karamian<sup>2</sup>, Mohammad Barati<sup>2</sup>

<sup>1</sup>Sama Technical and Vocational College, Islamic Azad University, Najafabad Branch, Najafabad, Iran

<sup>2</sup>Advanced Materials Research Center, Faculty of Materials Engineering, Najafabad Branch, Islamic Azad University, Najafabad, Isfahan, Iran

\*Email of Corresponding Author: Gheisary@iauln.ac.ir

*Received: August 28, 2015; Accepted: October 25, 2015*

## Abstract

The output error of the globoidal cam mechanism can be considered as a relevant indicator of mechanism performance, because it determines kinematic and dynamical behavior of mechanical transmission. Based on the differential geometry and the rigid body transformations, the mathematical model of surface geometry of the globoidal cam is established. Then we present the analytical expression of the output error (including the transmission error and the displacement error along the output axis) by considering different manufacture and assembly errors. The effects of the center distance error, the perpendicular error between input and output axes and the rotational angle error of the globoidal cam on the output error are systematically analyzed. A globoidal cam mechanism which is widely used in automatic tool changer of CNC machines is applied for illustration. Our results show that the perpendicular error and the rotational angle error have little effects on the transmission error but have great effects on the displacement error along the output axis. This study plays an important role in the design, manufacture and assembly of the globoidal cam mechanism.

## Keywords

Globoidal cam mechanism, Manufacture error, Transmission error, Automatic tool changer

## 1. Introduction

Due to the advantages of high loading capacity, low noise, low vibration, and high reliability as compared with some traditional intermittent-motion mechanisms, roller gear cam mechanisms are widely applied in industry [1]. A globoidal cam mechanism with a turret is shown in Fig. 1.

The output error of the globoidal cam mechanism includes the transmission error and the displacement error along the output axis. The transmission error is the difference between the actual angular position of the output shaft and the theoretical position it would have [2]. According to Coy [3], the transmission error is the main source of dynamic excitation of the gear. The literatures of the globoidal cam mechanism have been focused on the surface geometry of the globoidal cam [4], the pressure angles, curvatures [5- 7], the force, and the efficiency [8, 9]. However, the transmission errors of the globoidal cam mechanisms have not been widely studied.

Cheng [10] synthesized the optimum tolerances with minimizing manufacturing cost for globoidal cam mechanism. Tsay et al. [11] identified the analytical expressions for the turret motion and indexing accuracy of intermittent grooved globoidal cam mechanisms. Bu et al. [12, 13]

investigated the machine error resulting from the motion error of machine tool and the location error of the machined part. However, the effects of center distance error, the perpendicular error between the input and output axes and the rotational angle error of the globoidal cam on the output error of the globoidal cam mechanism haven't been given attention.

In reality, the globoidal cam surfaces are machined by the milling process firstly. After the heat treatment, the globoidal cam should be re-installed for the grinding process. Therefore, it is important to study the manufacture error and the assembly error of the globoidal cam mechanism. Center distance error, the perpendicular error between the input and output axes and the rotational angle error of the globoidal cam whether from manufacture error of assembly error may cause the output error of the globoidal cam mechanism. The analysis of the output error plays a leading role in the design, manufacture and assembly of globoidal cam mechanism.

In this article, the analytical expression of the surface geometry of the globoidal cam is firstly presented. Then, the expression of the transmission error resulting from center distance error, the perpendicular error between the input and output axes and the rotational angle error of the globoidal cam are derived and analyzed. A globoidal cam mechanism applied in automatic tool changer of CNC machines is applied for demonstration. Later, the comparison of the effects of the three errors is carried out. Those results are the basis for the optimal tolerance synthesis of manufacture and assembly errors of globoidal cam mechanism.

## **2. Surface Generation of Globoidal Cam**

As shown in Figure 1, the rollers mounted on the turret wheel are driven by the globoidal cam surface to generate intermittent, rotational motion. The generating method is widely applied to machine the globoidal cam. In the machining process, the roller is equivalent to the cutting tool, which is fixed at a distance from the globoidal cam. The tool path of the cutter is set to follow the relative motion between the globoidal cam and the roller. In order to increase the rigidity of the machine tool, the swivel motion of the spindle is replaced by the swivel motion of the cam blank. In other words, the cam blank rotates about its own axis and swivels around the machining spindle. Thus the globoidal cam surface can be considered as the spatial envelope formed by the cutter as it moves relative to the cam.

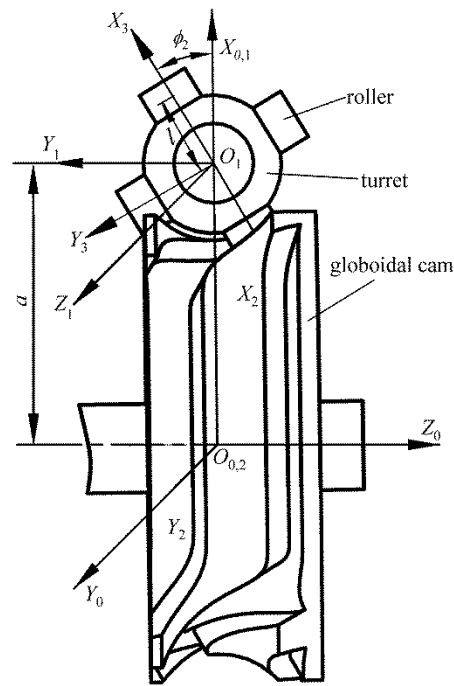

Figure1. The coordinate systems of globoidal cam mechanism

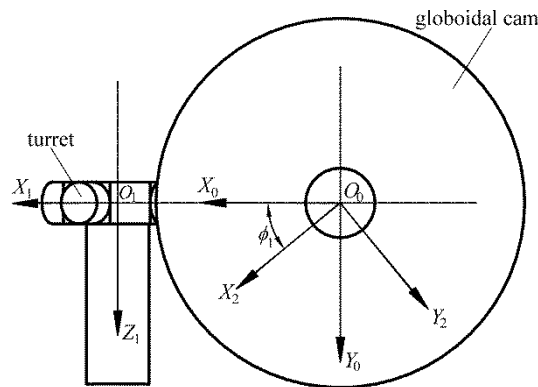

Figure2. The coordinate system attached to the globoidal cam

The coordinate systems of the globoidal cam mechanism with four cylindrical rollers are shown in Figure 1 and Figure 2 the coordinate systems  $O_0X_0Y_0Z_0$  and  $O_1X_1Y_1Z_1$  are the fixed coordinate systems attached to the globoidal cam and the turret, respectively.  $X_0$  axis and  $X_1$  axis are along the perpendicular line between the globoidal cam and the turret wheel.  $Z_0$  axis and  $Z_1$  axis align with the rotation axes of the globoidal cam and the turret wheel, respectively. The center distance between  $Z_0$  axis and  $Z_1$  axis is noted by  $a$ . The moving coordinate systems  $O_2X_2Y_2Z_2$  and  $O_3X_3Y_3Z_3$  are attached to the globoidal cam and the turret wheel, respectively. The input angle of the globoidal cam (See Fig. 2) and the output rotational angle of the turret are noted as  $\phi_1$  and  $\phi_2$ , respectively. Thus  $\phi_2(\phi_1)$  specifies the input-output relation of the globoidal cam mechanism, and is determined by the motion curve of the mechanism. As shown in Fig. 1, the radial distance from  $O_2$  to the axial section of the roller is  $l$ .

The position vector  $\mathbf{P}_0$  of the axial position of the cutter in the fixed coordinate system  $O_0X_0Y_0Z_0$

can be written as:

$$P_0 = (a - l \cos \phi_2 \quad 0 \quad l \sin \phi_2) \quad (1)$$

The transformation matrix from the coordinate system  $O_0X_0Y_0Z_0$  to the coordinate system  $O_2X_2Y_2Z_2$  can be represented as:

$$M_{20} = \begin{bmatrix} \cos \phi_1 & \sin \phi_1 & 0 \\ -\sin \phi_1 & \cos \phi_1 & 0 \\ 0 & 0 & 1 \end{bmatrix} \quad (2)$$

The pitch surface of the globoidal cam  $S(\phi_1, l)$  can be yielded as:

$$S(\phi_1, l) = M_{20} P_0 = \begin{bmatrix} (a - l \cos \phi_2) \cos \phi_1 \\ -(a - l \cos \phi_2) \sin \phi_1 \\ l \sin \phi_2 \end{bmatrix} \quad (3)$$

The unit normal vector  $n$  of the pitch surface of the globoidal cam can be written as:

$$n = \frac{\frac{\partial S}{\partial l} \times \frac{\partial S}{\partial \phi_1}}{\left| \frac{\partial S}{\partial l} \times \frac{\partial S}{\partial \phi_1} \right|} = \frac{1}{\sqrt{(a - l \cos \phi_2)^2 + l^2 \dot{\phi}_2^2}} \cdot \begin{bmatrix} l \dot{\phi}_2^2 \sin \phi_1 + (a - l \cos \phi_2) \cos \phi_1 \sin \phi_2 \\ b \dot{\phi}_2 \cos \phi_1 - (a - l \cos \phi_2) \sin \phi_1 \sin \phi_2 \\ (a - l \cos \phi_2) \cos \phi_2 \end{bmatrix} \quad (4)$$

According to the differential geometry, the globoidal cam surface can be obtained by offsetting the pitch surface along the normal vector at a distance equal to the radius of the cutter.

$$S_{1,2}(\phi_1, l) = S(\phi_1, l) \pm rn \quad (5)$$

Where  $\pm$  sign is result from the two side surfaces of the globoidal cam.

### 3. Transmission Error and Displacement Error

According to the definition, the transmission error  $TE$  can be written as:

$$TE = \phi_{2,out} - \phi_2 \quad (6)$$

Where  $\phi_{2,out}$  is the output rotational angle of the turret considering the manufacture or assembly errors,  $\phi_2$  is the theoretical rotational angle of the turret. The output rotational angle of the turret can be evaluated by transforming the pitch surface of the globoidal cam to the coordinate system attached to the turret.

In the globoidal cam mechanism, the rotational axes of the globoidal cam and the turret  $Z_0$  and  $Z_1$  are set to perpendicular. The perpendicular error between  $Z_0$  and  $Z_1$  axes can be represented as

$\Delta\varphi$ (See Fig. 3). In this case, the rotation axis of the globoidal cam aligns with  $Z_0'$ . The center distance error of the globoidal cam can be noted as  $\Delta a$ . The rotational angle error of the globoidal cam can be represented as  $\Delta\phi_1$ .

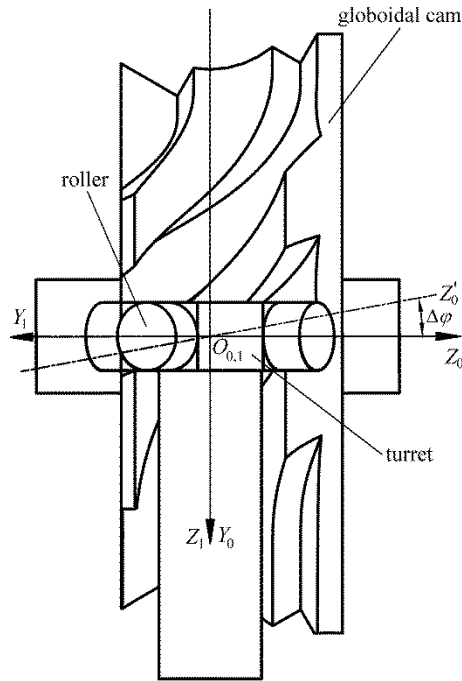

Figure3. The perpendicular error of globoidal cam mechanism

The transmission matrix  $M_T$  from the coordinate system  $O_0'X_0'Y_0'Z_0'$  to the coordinate system  $O_0X_0Y_0Z_0$  can be written as:

$$M_T = \begin{bmatrix} 1 & 0 & 0 \\ 0 & \cos(\Delta\varphi) & -\sin(\Delta\varphi) \\ 0 & \sin(\Delta\varphi) & \cos(\Delta\varphi) \end{bmatrix} \quad (7)$$

In order to investigate the transmission error, it is necessary to calculate the output rotational angle of the turret with respect to the coordinate system  $O_1X_1Y_1Z_1$ . The output angle  $\phi_{2,out}$  can be yielded by transforming the pitch surface of the globoidal cam to the coordinate system  $O_1X_1Y_1Z_1$ . With the rotation angle of the globoidal cam  $(\phi_1 + \Delta\phi_1)$ , the meshing position vector of the pitch surface with the turret roller in the coordinate system  $O_0'X_0'Y_0'Z_0'$  can be obtained as:

$$R_M = \begin{bmatrix} \cos(\phi_1 + \Delta\phi_1) & -\sin(\phi_1 + \Delta\phi_1) & 0 \\ \sin(\phi_1 + \Delta\phi_1) & \cos(\phi_1 + \Delta\phi_1) & 0 \\ 0 & 0 & 1 \end{bmatrix} \cdot S(\phi_1, l) \quad (8)$$

Thus, the meshing position of the pitch surface with respect to the coordinate system  $O_1X_1Y_1Z_1$  can be yielded as:

$$\mathbf{R}_F = \begin{bmatrix} 1 & 0 & 0 & -(a + \Delta a) \\ 0 & 0 & -1 & 0 \\ 0 & 1 & 0 & 0 \\ 0 & 0 & 0 & 1 \end{bmatrix} \mathbf{M}_T \mathbf{R}_M \quad (9)$$

$$= \begin{bmatrix} (a - l \cos \phi_2) \cos(\Delta \phi_1) - a - \Delta a \\ -(a - l \cos \phi_2) \sin(\Delta \phi_1) \sin(\Delta \varphi) - l \sin \phi_2 \cos(\Delta \varphi) \\ (a - l \cos \phi_2) \sin(\Delta \phi_1) \cos(\Delta \varphi) - l \sin \phi_2 \sin(\Delta \varphi) \end{bmatrix}$$

The output angle of the turret  $\phi_{2,out}$  can be yielded as:

$$\phi_{2,out} = \arctan \left\{ \frac{[-(a - l \cos \phi_2) \sin(\Delta \phi_1) \sin(\Delta \varphi) - l \sin \phi_2 \cos(\Delta \varphi)]}{[(a - l \cos \phi_2) \cos(\Delta \phi_1) - a - \Delta a]} \right\}. \quad (10)$$

The transmission error of the turret can be determined as:

$$TE = \arctan \left\{ \frac{[-(a - l \cos \phi_2) \sin(\Delta \phi_1) \sin(\Delta \varphi) - l \sin \phi_2 \cos(\Delta \varphi)]}{[(a - l \cos \phi_2) \cos(\Delta \phi_1) - a - \Delta a]} \right\} - \phi_2. \quad (11)$$

It can be noticed from (9) that the turret has the displacement error along  $Z_1$  axis. The turret error  $TZ$  along  $Z_1$  axis can be written as:

$$TZ = (a - l \cos \phi_2) \sin(\Delta \phi_1) \cos(\Delta \varphi) - l \sin \phi_2 \sin(\Delta \varphi). \quad (12)$$

#### 4. An Application Example

A TC40 type of globoidal cam which is used in Automatic tool changer of CNC machines is utilized to demonstrate the usefulness and effectiveness of this study. The center distance of the globoidal cam mechanism  $a$  is 160 mm. The range of  $l$  is from 37.5 mm to 54.5 mm, and the radius of the cylindrical roller is 15 mm. The motion program of the globoidal cam mechanism is determined by  $\phi_2 = \phi_2(\phi_1)$ , and the selected motion curve is modified sine curve. The original rotational angle of the turret is  $-30^\circ$ . The globoidal cam mechanism is in the dwell period during the cam rotation period of  $(-2, 2)$ ,  $(52, 122.5)$  and  $(237.5, 308)$ , and the rotational angle of the turret is  $90^\circ$ ,  $270^\circ$  and  $180^\circ$ , respectively. The other periods of  $\phi_1$  are in the indexing periods. According to the motion sequences and the motion curves of the globoidal cam mechanism, the mapping of the grooves of the globoidal cam is shown in Figure 4.

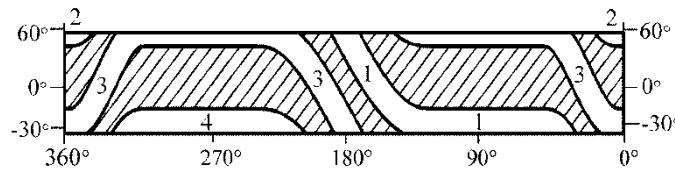

Figure4. The mapping of the globoidal cam

The transmission error of the turret resulting from the rotational angle error of the globoidal cam is calculated. For the error  $\Delta \phi_1 = 0.1^\circ$ , the results are shown in Figure 5.

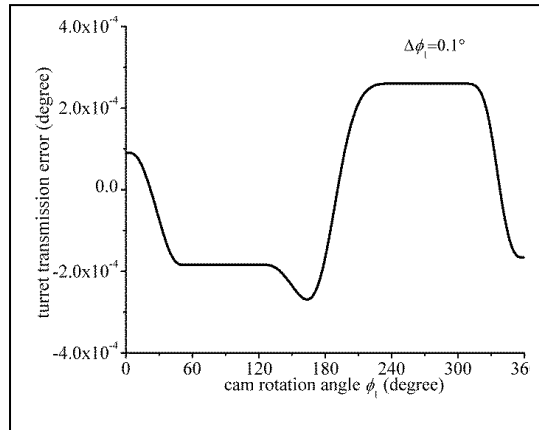

Figure5. The transmission error of the turret for  $\Delta\phi_1=0.1^\circ$

It can be seen from Fig. 5 that the rotational angle error of the globoidal cam has little effect on the transmission error of the turret. Because the maximum transmission error of the turret is nearly  $2.5 \times 10^{-4}$  when  $\Delta\phi_1=0.1^\circ$ . However, the turret error along  $Z_1$  axis is significant as shown in Figure 6. It is shown that the maximum turret error along  $Z_1$  axis is about 0.40 mm when  $\Delta\phi_1=0.1^\circ$ .

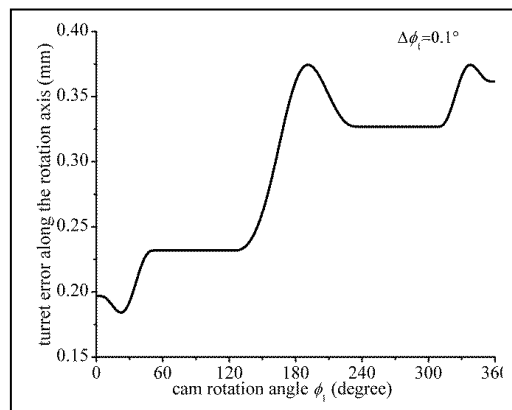

Figure6. Turret error along  $Z_1$  axis for  $\Delta\phi_1=0.1^\circ$

For the perpendicular error  $\Delta\varphi = 0.1^\circ$ , the transmission error of the turret is shown in Figure 7. It can be easily noticed that the effect of the perpendicular error between the two rotation axes on the transmission error can be neglected. However, the effect on the turret error along  $Z_1$  axis is great. As shown in Figure 8, the maximum  $TZ$  is nearly 0.1 mm.

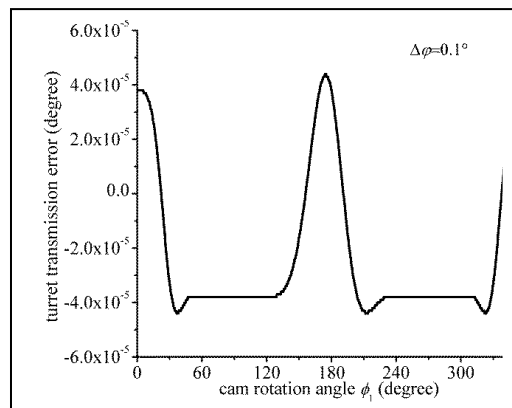
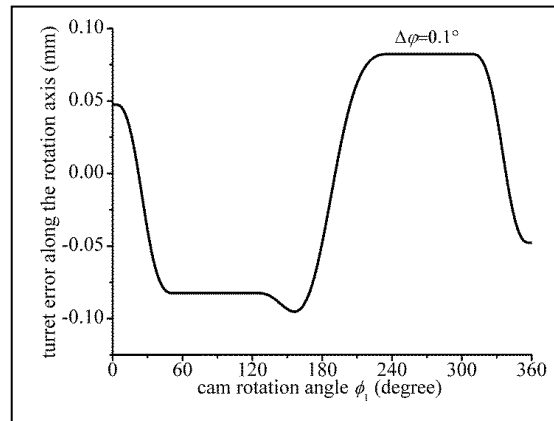
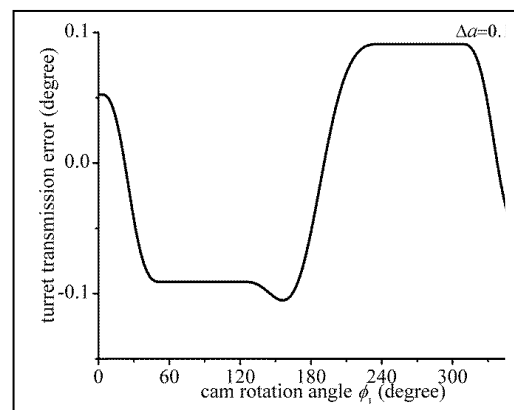

Figure7. The transmission error of the turret for  $\Delta\varphi=0.1^\circ$

Figure8. Turret error along  $Z_1$  axis for  $\Delta\phi=0.1^\circ$ 

By comparing the transmission error in Figure 5 and Figure 7, we can find that  $\Delta\phi_1$  and  $\Delta\phi$  have little effect on the transmission error. In addition the effect of  $\Delta\phi$  on  $TE$  is much slighter. According to Figure 6 and Figure 8,  $\Delta\phi_1$  and  $\Delta\phi$  has a significant effect on the turret error  $TZ$  along the rotation axis. By comparing with  $TZ$  resulting from  $\Delta\phi_1$  and  $\Delta\phi$ , the effect of  $\Delta\phi_1$  on  $TZ$  is much greater than that of  $\Delta\phi$ . In the working process of the globoidal cam mechanism, the transmission error as well as the displacement error along  $Z_1$  axis has a great effect on the performance of the mechanism. Thus, the rotational angle error of the globoidal cam and the perpendicular error between rotational axes must be strictly controlled. The transmission error resulting from the center distance error ( $\Delta a = 0.1$  mm) is shown in Figure 9. It is shown that  $\Delta a$  has great effect on the transmission error of the turret. The maximum  $TE$  is nearly  $0.1^\circ$  when  $\Delta a = 0.1$  mm. However,  $\Delta a$  has no effect on  $TZ$ .

Figure9. Transmission error of the turret for  $\Delta a = 0.1$  mm

## 5. Conclusion

In this study, the effects of manufacture errors and assembly errors on output error of the globoidal cam mechanism are systematically analyzed and calculated with the help of VC++ Software. The effects of the rotational angle error of the globoidal cam, the perpendicular error between the input and output axes and the center distance error on the turret output error of the globoidal cam mechanism are compared and analyzed. The main findings are as follows:

1) A methodology to calculate the output rotation error and the output displacement error along the output axis is presented. The presented methodology can be applied to derive the output errors of



various spatial cam mechanisms.

2) The rotational angle error of the cam and perpendicular error between input and output axes have little effect on the transmission error. However, they have a great effect on the displacement error of the turret along the output axis. The center distance error has a great effect on the transmission error, whereas has no effect on the displacement error along the output axis.

3) The effect of the perpendicular error  $\Delta\varphi$  on the transmission error is much slighter than that of the rotational angle error  $\Delta\phi_1$  of the globoidal cam. Moreover, the effect of  $\Delta\varphi$  on the displacement error along the output axis is also slighter than that of  $\Delta\phi_1$ .

In the process of manufacture and assembly, the rotational angle error of the globoidal cam, the perpendicular error between two rotation axes and the center distance error should be strictly controlled. The results of this study are the basis for the optimal tolerance synthesis of manufacture and assembly errors of globoidal cam mechanism.

## 6. References

- [1] Yan, H. S. and Chen, H. H. 1996. Geometry design of globoidal cams with generalized meshing turret-rollers, *Trans. ASME J. Mech. Des.*, 118, 243–249.
- [2] Astoul, J., Mermoz, E., Sartor, M., Linares, J. M. and Bernard, A. 2014. New methodology to reduce the transmission error of the spiral bevel gears, *CIRP Annals – Manufacturing Technology*, 63, 165–168.
- [3] Coy, J. J., Handschuh, R. F., Lewicki, D. G., Huff, R. G., Krejsa, E. A. and Karchmer, A. M. 1987. Identification and proposed control of helicopter transmission noise at the source, *NASA/Army Rotorcraft Technology Conference*, California, 17–19.
- [4] Ji, S. T., Zhao, J. and Zhang, Y. M. 2015. An application of geodesics to the calculation of the rib-thickness of the globoidal cam mechanisms, *Mech. Mach. Theory*, 87, 163-176.
- [5] Tsay, D. M. and Lin, B. J. 1996. Improving the geometry design of cylindrical cams using nonparametric rational B-splines, *Comput. Aided Des.*, 28, 5-15.
- [6] Yan, H. S. and Chen, H. H. 1994. Geometry design and machining of roller gear cams with cylindrical rollers, *Mech. Mach. Theory*, 29, 803-812.
- [7] Yan, H. S. 1999. Curvature analysis of roller-follower cam mechanisms, *Math. Comput. Model.*, 29, 69-87.
- [8] Tsay, D. M. and Lin, B. J. 1997. Design and machining of globoidal index cams, *Trans. ASME J. Manuf. Sci. Eng.*, 119, 21-29.
- [9] Kuang, J. H., Hsu, C. M. and Hu, C. C. 2010. Dynamic behavior of globoidal cam systems with torque compensation mechanisms, *Mech. Mach. Theory*, 45, 1201-1214.
- [10] Cheng, H. Y. 2002. Optimum tolerances synthesis for globoidal cam mechanisms, *JSME*, 45, 519-526.
- [11] Tsay, D. M. and Ho, H. C. 2001. Consideration of manufacturing parameters in the design of grooved globoidal cam indexing mechanisms, *Proc. IMechE C J. Mech. Eng. Sci.*, 215, 95-103.
- [12] Bu, F. H., Zhang, Y. M. and Shang, D. G. 2012. Study on machining error of globoidal cam profile resulting from motion error of machine tool in machining, *Applied Mechanics and Materials*, 148-149, 1356-1364.

- [13] Bu, F. H., Zhang, Y. M. and Shang, D. G. 2012. Study on machining error of globoidal cam profile resulting from rotational deviation of location of part in machining, *Advanced Materials Research*, 452-453, 211-218.