

RESEARCH ARTICLE

Open Access

Implementation of Two Assessment Models Based on Failure Rate and NDEA in Production Supply Chains with the Approach of Choosing the Right Supplier

Mehdi Latiffee¹, Morteza Shafiee^{2*}

Abstract

One of the important issues in the supply chain is the selection of reliable and efficient suppliers, which improves performance and competitive advantage. Therefore, the aim of this research is to implement two evaluation models based on failure rate and NDEA with the approach of choosing the right supplier in 7 separate supply chains of an electrical appliance manufacturing company in Shiraz. In this direction, a series-parallel system was used to evaluate based on the failure rate, which at the first level examines the reliability of the suppliers and at the second level examines the reliability of the devices required for the production of electrical appliances. And in order to calculate the efficiency of suppliers, the NDEA model was also used. The results showed that both presented approaches are suitable for evaluating the performance of the supply chain, because the performance rating of both models has high resolution.

Keywords: *Performance Evaluation, Supply Chain, Model Based on Failure Rate, Reliability, Network Data Envelopment Analysis (NDEA)*

Introduction

The supply chain is a network of facilities and operations that are responsible for the processing and development of the product, procurement of materials from suppliers until the product reaches the final customer. Therefore, placing the inputs in the form of the supply chain will reduce the cost, improve the response to changes, increase the level of service and facilitate decision-making (Golpîra et al, 2021) On the other hand, developing a suitable architecture for the components of a supply chain and how they interact is one of the main concerns of managers, decision makers and activists in this field. Various people and companies are active in the supply chain, which include;

there are suppliers, producers, distributors and consumers, so it is very important to consider all these levels simultaneously in network design (Zhang et al, 2020). For this reason, the key issue in a supply chain is the management and control of coordination at all these levels. Therefore, one of the approaches that can be used to manage and control the performance of the supply chain is to check its reliability. In fact, this approach has received increasing attention in recent years, because it reduces the risks and uncertainties of the supply chain (Ha et al, 2018). For this purpose, in this research, the evaluation of the supply chain and the calculation of reliability with the approach based on the failure rate have been done.

1. Ph.D. Candidate, Department of Industrial Management, Faculty of Management, Dehaghan Branch, Islamic Azad University, Dehaghan, Iran

2*. Associate Prof, Department of Industrial Management, Faculty of Economics and Management, Shiraz Branch, Islamic Azad University, Shiraz, Iran (Corresponding Author: shafiee@iaushiraz.ac.ir)

Also, another important issue that plays a fundamental role in the management, control and coordination of the supply chain levels is the evaluation of its efficiency, so another powerful approach that helps to evaluate the efficiency of the supply chain is the technique of data envelopment analysis (Liao and Kao, 2011).

In fact, this technique is a linear and non-parametric programming method to evaluate the relative efficiency of a group of decision-making units. This method determines the relative efficiency score of decision-making units and identifies a set of efficient units that can be used as a model to improve decision-making units (Shiripour and Adib, 2019); But data envelopment analysis also has limitations like other methods, one of these limitations of using this technique is that the traditional models of data envelopment analysis such as CCR and BCC model, intermediate products and the connection of activities between different parts within the system. are ignored and in this case the relative efficiency of the decision-making units is evaluated according to the inputs that are used to produce the final output, therefore, it is not enough to evaluate the performance of the supply chain in which only the initial inputs and the final output are considered, Because the connection of internal activities between suppliers, manufacturers, distributors and customers is ignored and performance improvement in one part of the supply chain does not lead to the improvement of the entire chain. Consequently, to effectively measure supply chain performance, it is necessary to consider the complex multi-level structure between different entities (Shiripour and Adib, 2019). Therefore, in order to solve this problem, in this research, the network data envelopment analysis model was used. On the other hand, one of the important points and the basic pillar in supply chain management is paying attention to suppliers; Because choosing a suitable supplier is a key factor to improve competitiveness in the organization and considering that suppliers form a major part of the supply chain, they can have a

significant impact on the strategic success of the supply chain and specifically on the performance of the chain in terms of price, quality, technology and have delivery (Nilforoushan and Tahanian, 2017). Therefore, considering the role of the supply chain in production, as well as the importance of the issue of decision making for the selection of suppliers and its undeniable effects on the entire production process, the purpose of this research is: To investigate the efficiency and reliability of 7 supply chains of an electrical appliance manufacturing company in Shiraz with the evaluation model based on failure rate and NDEA model. Also each of these supply chains has 8 suppliers. In this regard, by means of the failure-based evaluation model, it calculates the reliability, calculates the failure rate of the supplier's manufactured product to compare the output quality and rank the suppliers. Then it also obtains the reliability of the devices and equipment needed in the production of electrical appliances and finally calculates the reliability of the entire production supply chain. Also, by means of the NDEA model, it evaluates the efficiency of the studied supply chains and ranks the suppliers. Finally, while using the advantages of both methods, it examines the performance of each in choosing the right supplier. Therefore, the main goal of this research is to determine the reliability and efficiency of all members of these 7 supply chains with the approach of choosing the right supplier; and the main problem of the current research is to answer the following questions:

1. How to choose the right supplier in the production supply chain based on the reliability and evaluation model based on the failure rate?
2. How to choose the right supplier in the production supply chain based on the pattern of network data envelopment analysis?

Literature Review

Supply chain means forming physical, informational, and financial and knowledge processes in order to satisfy the needs of the

final consumer through products and services related to suppliers. Supply chain management also includes: design, maintenance and operation of supply chain processes to meet the needs of the final consumer (Ayers, 2006). Therefore, one of the important goals of supply chain management is to coordinate all the activities or different constraints of the chain, so that the goods can be provided to the customers at the required time when the inventory is low and the costs are low. Unfortunately, different components in the supply chain do not always

cooperate with each other to produce a product or service, and this creates a difficult situation for supply chain management (Adel abd Momeni, 2020) one of these components are suppliers. Therefore, evaluating suppliers and supporting their continuous improvement has become a very important role for supply chain management, and the performance of an organization in the supply chain depends on the performance of its suppliers (Tseng et al, 2009), in figure (1) the importance of choosing the right suppliers in the chain provided is:

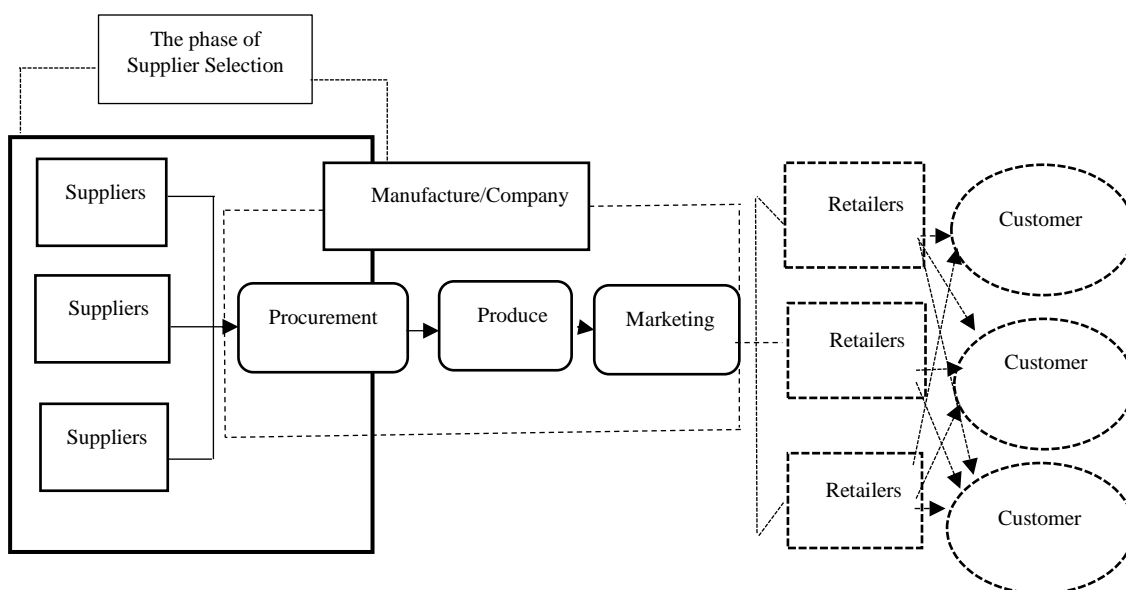

Figure 1. The position of supplier selection in the supply chain (Liao and Kao, 2011:10804)

Also, today, with the change of business conditions, the shortening of the life cycle of products, the blurring of business boundaries, the change of customer expectations, business owners have distanced themselves from traditional management ideas and turned to new management methods and techniques to evaluate the performance of the supply chain and select the best suppliers (Sandtrov and Rausand, 1991). One of these techniques used in this research is to obtain reliability with the "failure rate-based" evaluation model. In fact, reliability is a general concept that has been known for years as a positive feature for a person or a product. Its beginnings in 1816 were much older than many would have guessed. The word "reliability" was coined for the first time

by a poet named Samuel Taylor Coleridge (Karbasiyan and Tabatabai, 2014). After that, in 1912, after the Titanic ship accident, a study and research was conducted in the field of designing systems with parallel components or storage by researchers to prevent similar accidents. Then in the 1940s, with the beginning of World War II and the construction of complex military tools, the discussion of reliability modeling was carried out by Loser and Murphy. During this period, many reliability related works were done by testing materials and their fatigue. Therefore, the first articles in the field of reliability were published by Miner under the title "Cumulative failures in fatigue" in 1945 (Ebrahimi, 1988). It can be said that despite the many works to increase the life and

reliability of the product done in the past, but the beginning of the concept of reliability in its current form was in the 1940s. In general, reliability is a process that determines what needs to be done to ensure that a system will perform its tasks correctly; the meaning of the system in this research is the supply chain. Therefore, the reliability of a system or supply chain is the probability of satisfactory performance of that system under certain working conditions and for a certain period of time. Reliability includes four main parts of probability, satisfactory performance, time and certain working conditions, whose probability is expressed with a number, which is the reliability evaluation index. In many cases, this index is the most important index. It can also be said that uncertainty in the supply chain affects its performance. Supply chain uncertainty comes from three source (Stadtler, 2005):

- A) Uncertainty of the supplier, which is caused by the supplier's inability to meet the needs of the production unit.
- b) Uncertainty of the process that takes place as a result of distrust of the production process and due to the failure of machinery.
- C) Uncertainty of demand that comes from the inability to accurately predict demand.

Also, calculating the reliability of the entire supply chain is required to calculate the reliability of each part, and considering that the links of the supply chain are usually series, therefore the reliability of the entire supply chain is smaller than its individual links, so the chain management should try to improve the reliability as much as possible increase the reliability of each member and increase the reliability of the entire chain by choosing the best suppliers and manufacturers and distributors in the best arrangement and with high flexibility (Pryke, 2009); which is fully described in the next section. On the other hand, another new management technique to evaluate supply chain performance and select effective suppliers is the DEA approach. This non-parametric method is based on the work of an economist named Farrell (Farrell, 1957), who presented it in 1957 to determine efficiency

in the case of two inputs and one output. Although Farrell's method solved the problem related to the selection of the production function, it still had the problem of the number of inputs and outputs. In 1978, Charnes, Cooper and Rhodes (Charnes et al, 1978) extended Farrell's non-parametric method to multiple inputs and outputs and presented the well-known CCR model assuming constant returns to scale, and in 1984, Banker, Charnes and Cooper (Banker et al, 1984) they extended the CCR model for efficiency to a variable scale and presented the famous BCC model. The purpose of data envelopment analysis models is to determine the efficiency of a system or decision-making unit through the process of how inputs are converted into outputs. In other words; the goal is to identify the units that obtain the highest output from the lowest input, such a unit that has an efficiency equal to one is called an efficient unit, and other units that have an efficiency between zero and one are known as inefficient units. DEA allows this possibility that managers have a correct assessment of their units and make correct and rational decisions for the optimal allocation of resources (Jahanshahloo et al, 2016). However, traditional data analysis models in evaluating the efficiency of organizations ignore the relationship between activities or internal activities and do not have the ability to deal with multi-sector organizations (Tone and Tsutsui, 2009). This issue also applies to the supply chain, which consists of several different parts, so in order to solve this problem, the network data envelopment analysis model was used. In this model, the goal is to determine the efficiency of the main decision-making unit as well as sub-decision-making units or sub-units. In this case, the efficiency of the sub-units is evaluated in addition to the efficiency of the main units, and the inefficient sub-units are determined from the efficient sub-units. Therefore, the network model of data envelopment analysis allows decision-making unit managers to focus on strategies to increase the efficiency of certain parts of the process (Sexton and Lewis, 2003).

In the continuation of recent years' research in the field of supplier selection and data coverage analysis and the reliability approach based on the failure rate in order to use the experiences of other researchers and obtain the appropriate default of effective variables in evaluating the performance of the supply chain, it is presented.

Yazdi et al (2022) evaluated the performance of oil and gas industry suppliers using the MCDA model and concluded that suppliers play an important role in providing essential items such as equipment, human resources, and transportation, so choosing the best suppliers in all fields it reduces costs and increases income.

In a research, Ebrahimi and Bagheri (2021) focused on optimizing the profit and reliability of the oil and gas supply chain using a two-objective mathematical model, and the results showed that the proposed method of this research was chosen as the best approach in terms of time and objective function values.

Majchráková and Kremeňová (2021), in another study with the aim of choosing the best supplier, evaluated the performance of Siemens' supply chain using the multi-criteria decision-making model (MCDA) and concluded that transportation cost as an important criterion plays a significant role in supplier selection.

In a research, Zhang et al (2020) also designed a reliability model for the supply chain system using partial differential equations and concluded that due to the presence of many influencing factors, the supply chain system directly affects its reliability. And in this regard, how to analyze and improve the reliability of the supply chain is a must.

Izadikhah et al (2021) also evaluated a flexible and sustainable supply chain in public transportation using a two-stage DEA approach based on fuzzy chance. The proposed approach was validated and applied to evaluate a real case study involving 21 major providers of public transportation equipment in three metropolitan cities. The results showed that the proposed approach is

an advanced and accurate approach in evaluating the performance of resilient sustainable chains.

In another study, Hendiani et al (2020) also used a multi-stage hierarchical decision-making approach to select a sustainable supplier in one of the refineries in southern Iran, and the results showed that the proposed method can be used as a criterion for evaluating sustainability among suppliers.

Kalantary and Farzipoor Saen (2019) also introduced a dynamic and network DEA model to evaluate the stability of supply chains in different periods. The results showed that it is better for sustainable supply chains to invest in sustainable lines. In a research, Ha et al (2018) also presented a mathematical definition of supply chain reliability and related functions based on traditional reliability theory and structural reliability models for a computer assembly company. The results of this paper showed that the proposed functions and structural reliability models are applicable for different types of supply chain.

And Badiezadeh et al (2018) also developed an NDEA model to calculate optimistic and pessimistic efficiency. Their proposed model can incorporate adverse outputs and rank supply chains in terms of efficiency scores.

In Iran, a few researches have been carried out on the topic of research, which are as follows:

(Tavakkol et al, 2023) analyzed the triggers of the Bullwhip effect in the supply chain of the pharmaceutical industry and determined the critical triggers using the Dimetal technique. And they concluded that the inventory policy, price fluctuations, inventory storage of chain elements, structured inventory control process, difference from target inventory and information transparency are the main drivers of bullwhip effect in pharmaceutical industry supply chain.

Barzegar et al (2022) in a study presented a framework for reliability engineering and maintenance excellence (iREAM3), based on the principles of asset management, and the

research findings indicate that by implementing this framework in various organizations and industries of the country, key indicators The maintenance performance as well as the audit result of the organization's road map had a significant improvement, which proves the effectiveness of the framework according to the local conditions of the country.

(Marzban et al, 2022) also evaluated a perishable food supply chain in an article using the network data envelopment analysis model and concluded that according to the average efficiency of the studied supply chain, the most problems related to inefficiency to the supplier sector.

Also (Darvish Motevalli and Ebrahimi, 2021) examined a drug supply chain in three levels of supplier, distributor and consumer (pharmacies and private hospitals in Tehran) by means of a network data envelopment analysis model and concluded that Based on this model, 5 hospitals had an efficient supply network and 25 hospitals had an incomplete supply network. Also, the proposed model is able to evaluate the multi-level supply network and intermediate components in hospitals.

In a research, Chertab Jabari et al (2021) evaluated the efficiency of 5 supply chains in the automotive industry of Tabriz with the combined model of fuzzy data envelopment analysis and balanced scorecard, and while using the advantages of both models, they ranked the studied supply chains and the results showed that by increasing the level of confidence, the efficiency of the supply chains studied in the research also increases.

In another study, Golpîra et al (2021) presented a new mixed integer linear programming model to introduce an optimal framework for structuring a multi-project and multi-source construction supply chain network with multiple suppliers for large construction companies with Decentralized procurement strategy was discussed and the results showed that the presented model provides the possibility of choosing the right size for the construction supply chain along with the trade-off of quality and reliability.

In a study, Dehghan Khavari and Derakhsh (2021) also analyzed the structure of effective factors in hotel industry supply chain management using the fuzzy cognitive mapping approach, and the findings of the research indicate that the three criteria of service quality, advertising, and service quality of suppliers in The implementation of supply chain management in the hotel industry is more important than other criteria.

Shafiee et al (2021) also looked at finding patterns in the supply chain using data envelopment analysis and simulating system dynamics in the milk industries of Fars province and developed appropriate strategies to improve the efficiency of this industry.

Also, in another study, Shafiee et al (2021) evaluated the performance of the quality level and the ranking of the suppliers of precision instruments of Barzoye Petrochemical Company with the Nash approach and data envelopment analysis and came to the conclusion that due to the increase in competition in the field of global trade and the needs of domestic markets and Externally, evaluating the performance of the quality level of suppliers is considered essential for a petrochemical company, because it leads to the improvement of the competitive power and the increase of business opportunities.

In another study, Shahbandarzadeh and Behrouzi (2021) provided a model to evaluate the performance of the supply chain of National Bank branches under a two-step process with the help of data envelopment analysis and concluded that with the help of the presented model, they can make a more accurate assessment and reduce nodes in banks.

In a research, Fakhrzad et al (2019) presented a green-loop supply chain model in a multi-period, multi-level and multi-product mode under uncertainty, whose goals include minimizing the costs of the supply chain network, minimizing the emission of exhaust gases resulting from transportation. The means of transport is between the centers and the maximization of the reliability of the

delivery of the demand is according to the reliability defined for the suppliers. In another study, Mortazavi and Karbasian (2019) also evaluated the reliability of repairable multi-state systems by considering dependent failures by dynamic failure tree and dynamic Bayesian network, and also evaluated the reliability of a water pumping system by considering cascading failure.

And Naseri and Karimi (2019) also estimated the reliability of the supplier in the

condition of disturbance using Bayesian network and fuzzy approach. In this article, by examining the suppliers' disturbances and considering the relationship between them, and by using the fault tree analysis (FTA) method and converting it to a Bayesian network, the reliability of the supplier is estimated.

In the following table 1, the key differences between the present study and the previous studies are given:

Table 1.

Key differences between the present study and previous studies

year of publication	Researchers	Supply chain assessment	Reliability	Data envelopment analysis	Rating of suppliers
2018	Badiezadeh et al	✓		✓	
2018	Ha et al	✓	✓		
2019	Kalantary and Farzipoor Saen	✓		✓	
2019	Fakhrzad et al	✓	✓		
2019	Mortazavi and Karbasian	✓	✓		✓
2019	Naseri and karimi	✓	✓		
2020	Hendiani et al.	✓			✓
2020	Zhang et al.	✓	✓		
2021	Ebrahimi and Bagheri	✓	✓		
2021	Majchráková and Kremeňová [27]	✓			✓
2021	Yazdi et al	✓			✓
2021	Izadikhah et al ; Chertab Jabari et al.	✓		✓	
2021	Golpîra et al; Dehghan Khavari et al	✓			
2021	Shafiee et al.	✓		✓	✓
2021	shafiee et al.	✓		✓	
2021	Shahbandarzadeh and Behrouzi	✓		✓	
2021	Darvish Motevalli and Ebrahimi,	✓		✓	
2022	Barzegar et al	✓	✓		
2022	Marzban et al	✓		✓	
2023	Tavakkol et al	✓		✓	
2023	current study	✓	✓	✓	✓

As it is clear from Table (1), previous studies have considered some of the aspects of performance evaluation of the supply chain and management, so in this research, it has been tried to consider more comprehensive aspects of performance evaluation. And with

two different approaches, "based on failure rate" and "NDEA" model, evaluate the performance of the supply chain with the aim of selecting the best supplier. So that while using the advantages of both approaches, practical action has been taken to eliminate

some of the shortcomings of both approaches and to consolidate some overlapping aspects. Therefore, first, a five-level one-way production supply chain was developed, the purpose of which is to determine the reliability and efficiency of all 7 supply chains studied in the research with the approach of selecting the appropriate supplier. Then, in order to implement and calculate the reliability of the supply chain, a new approach has been used compared to previous studies. In fact, in previous studies, either only the reliability of the primary parts of a company was calculated, or the reliability of the production equipment and devices of a company was calculated, but one of the advantages of this research is that it calculated the overall reliability of both mentioned items with the aim of choosing the best supplier. So that; According to the approach of the company under study in order to calculate the reliability of its production supply chains, a parallel-series system was designed and the reliability of individual parts and raw materials supplied by the suppliers of all 7 supply chains under study was obtained and according to numerical which was found to be the supplier's reliability evaluation index, the suppliers' ranking in each of the studied supply chains was discussed. In addition, the reliability of the production equipment and devices of the studied company was also obtained and finally the overall reliability of the supply chain was calculated. In order to calculate the efficiency of the supply chain with the aim of ranking the suppliers, a two-stage data envelopment analysis model has been used, with which the partial efficiency of each step and the cumulative efficiency of the supply chain can be obtained, and in this regard, it has been tried to use indicators and criteria. so that they can be used to evaluate the suppliers of the electrical appliances company under study and finally, the performance of both reliability approaches based on failure rate model and NDEA were investigated in the evaluation and ranking of suppliers in order to get a more comprehensive view of the use of each. In fact, the basis of the approaches

used in this research is that managers can obtain their reliability and efficiency by considering the cooperation relationships between suppliers and also be able to rank them completely. From this point of view, our proposed approach is also practical for use in similar organizations.

Also, one of the advantages of this method is that the following can be listed:

1. Implementation of the five-level research supply chain.
2. Evaluation of the research supply chain horizontally with the Reliability approach based on failure rate and vertically with the Data Envelopment Analysis approach.
3. Implementation of the reliability model in the form of a series-parallel hybrid system and ranking of suppliers.
4. Calculating the reliability of primary materials and parts based on failure rate.
5. Calculating the reliability of equipment and devices based on failure rate.
6. Implementation of Network Data envelopment Analysis model and ranking of suppliers.
7. Comparison of the Reliability model and Network Data envelopment Analysis model in the supply chain evaluation with the approach of selecting the best supplier by means of statistical indicators.

Research Methodology

In this part, the general steps of implementing the used approaches and the conceptual model of the research that evaluates the supply chain and finally the best approach that determines the suppliers are described. Since the purpose of the research is to design a mathematical model to evaluate the efficiency and calculate the reliability of the supply chain of a production system, therefore, in terms of the purpose and nature of the research method used, it is of an applied type, and in terms of collecting descriptive information and its method, it is of a contextual-case type because, for Demonstrating the reliability and efficiency of the model and the theoretical findings obtained from the model have been used practically and in real conditions in an

electrical appliance manufacturing company in Shiraz, therefore, the research method of the current research is of the contextual-case type and is specifically based on mathematical modeling. Also, the statistical population of the research includes several sections. The first part, in terms of identifying and prioritizing the indicators and factors affecting the efficiency of the production supply chain of the research, includes the opinions of two experts related to the specialized field of maintenance and repairs, two experts of product management, one

expert of technical and engineering services, and the president of the company under study, which is a total of 6 people experts; that according to the type and nature of the research and in order to improve the reliability and accuracy of the research, we have tried to use experts who are somehow involved in the evaluation of suppliers; And the second part of the statistical population is also in terms of suppliers, which includes 56 supplier companies, which are classified in Table (2):

Table 2.

The statistical population of the research in terms of suppliers

Electronic parts supplier company							
Supplie r1	Supplie r2	Supplie r3	Supplie r4	Supplie r5	Supplie r6	Supplie r7	Supplie r8
Wire suppliers company							
Supplie r1	Supplie r2	Supplie r3	Supplie r4	Supplie r5	Supplie r6	Supplie r7	Supplie r8
Screw suppliers company							
Supplie r1	Supplie r2	Supplie r3	Supplie r4	Supplie r5	Supplie r6	Supplie r7	Supplie r8
Cable suppliers company							
Supplie r1	Supplie r2	Supplie r3	Supplie r4	Supplie r5	Supplie r6	Supplie r7	Supplie r8
Board suppliers company							
Supplie r1	Supplie r2	Supplie r3	Supplie r4	Supplie r5	Supplie r6	Supplie r7	Supplie r8
ABS material supplier company							
Supplie r1	Supplie r2	Supplie r3	Supplie r4	Supplie r5	Supplie r6	Supplie r7	Supplie r8
Box suppliers company							
Supplie r1	Supplie r2	Supplie r3	Supplie r4	Supplie r5	Supplie r6	Supplie r7	Supplie r8

Also, due to the fact that the entire statistical community has been investigated and evaluated in this research, no sampling has been done in this research; and to analyze the data, mathematical functions have been used to calculate reliability and the mathematical model of Network Data Envelopment Analysis has been used to calculate efficiency. Also, SPSS, Excel and WINQSB software have been used for modeling and solving. Also, in this research, in order to collect information and identify indicators affecting the reliability and efficiency of the model, as well as the components and dimensions of the model,

theoretical-field studies have been conducted. Theoretical information and theoretical foundations related to the "failure rate-based" evaluation model approach and NDEA in order to evaluate suppliers are provided based on library studies and articles. And the information related to the identification of suppliers and the supply chain studied in this research has also been collected from the documents of the studied company. On the other hand, the requirement of any applied research is to study and know the effective parameters in the working field of the research. For this purpose, in order to identify and extract effective input, output and

intermediate indicators in order to calculate the reliability and evaluate the relative efficiency of the supply chain in the supplier sector, extensive field and library studies

were conducted on the available variables and indicators, which are described in Table (3) given:

Table 3.

Supply chain performance measurement indicators based on previous studies

year of publication	Researchers	index (sub index)
2017	Yazdani et al.	Capital, quality, price, timely delivery, product
2017	Wan et al.	Quality, cost, agility, general management capabilities
2018	Zhang et al.	Cost, quality, on-time delivery, service, net profit
2019	Jain and Singh	Quality, delivery, production, facilities, net price, technical capability, repair service, cooperation history, financial condition, net sales, communication system, reputation and position in the industry, flexibility, geographic location, reliability, process improvement, warranty and claims policies,.
2020	Hendiani et al.	Cost/price, quality, reliability, delivery, supply capacity, relationship terms, flexibility, service
2021	Yazdi et al.	Customer value, customer satisfaction, commitment, quality, cost, history, flexibility, trust, geographic location

Therefore, after reviewing and studying the articles, in order to fully understand all the research indicators, a guided interview was conducted in this field with the relevant

company officials and university professors, and through the checklist provided to these people, the indicators with the highest scores were selected. It is as described in Figure (2):

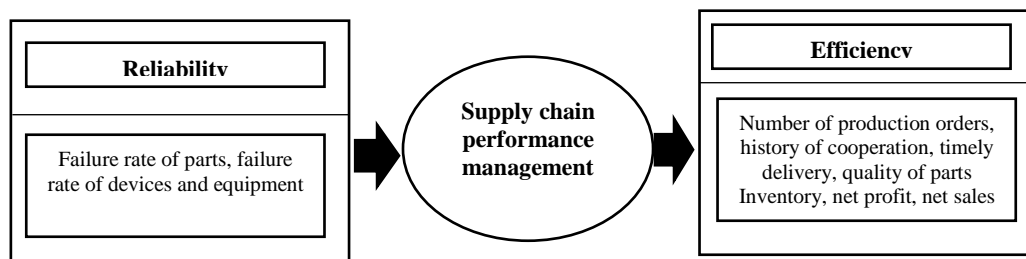

Figure 2. *Conceptual model of factors affecting supply chain performance*

In the above model, efficiency and reliability are introduced as criteria used to measure supply chain performance. Each of these criteria can be measured and evaluated using its own sub-indices. The dimensions of the model can be defined as follows:

Reliability: It is usually used to express a degree of assurance that a system will work successfully under certain conditions and over a certain period of time; In other words, reliability means the ability of a system or subsystem to correctly perform a specified and predefined mission under certain conditions and in a certain period of time.

Efficiency: It is a concept that evaluates the cost of resources spent in the process of

achieving the goal. In such a way that the comparison of the obtained outputs with the consumed inputs determines the level of efficiency; In other words, it is the efficiency of doing the right things in the organization.

Supply chain management: Supply chain management can be defined as a set of approaches used to optimally combine suppliers, manufacturers, sellers and stores, so that products are supplied in sufficient quantity and at the right time, in order to minimize system costs. And ultimately lead to customer satisfaction; therefore, according to this definition, the supply chain management process studied in this research is shown in Figure (3):

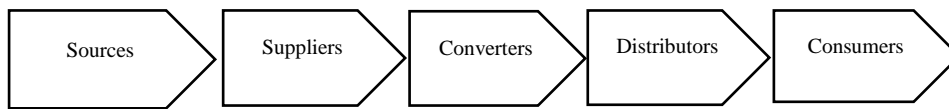

Figure 3. *The supply chain management process studied in the research*

Also, the research methodology is such that in order to calculate the reliability of the supply chain, the type of supply chain must be determined first and then the "failure rate-based" evaluation approach should be implemented. For this purpose, the reliability in the suppliers sector (checking the reliability of the primary parts) and also in the Converters sector (checking the reliability of the machinery for assembling the parts) is calculated with the aim of choosing the best supplier. Therefore, in order to select the best supplier according to the performance of the supply chain (Figure 2), reliability has been calculated with a series of reliability evaluation quantities. In the next step, the efficiency of suppliers has been calculated using the NDEA method, in order to check the ability of both mentioned methods to evaluate the performance of the supply chain. And finally, the performance of both methods was checked to determine the power of both

methods in calculating reliability and efficiency, and in the future, by using the information obtained from the mentioned models, steps can be taken to increase the efficiency and reliability of the company's products.

Supply chain evaluation model with supplier selection approach using "failure rate based" approach

The first step is to determine the type of supply chain system in this research, according to the processes of the company under study, a one-way 5-level supply chain is used, the first and last level of which are assumed to be outside the border, and its purpose is to determine the reliability and efficiency of this supply chain with The supplier selection approach is appropriate. Therefore, the supply chain subject to research evaluation is as described in Figure (4):

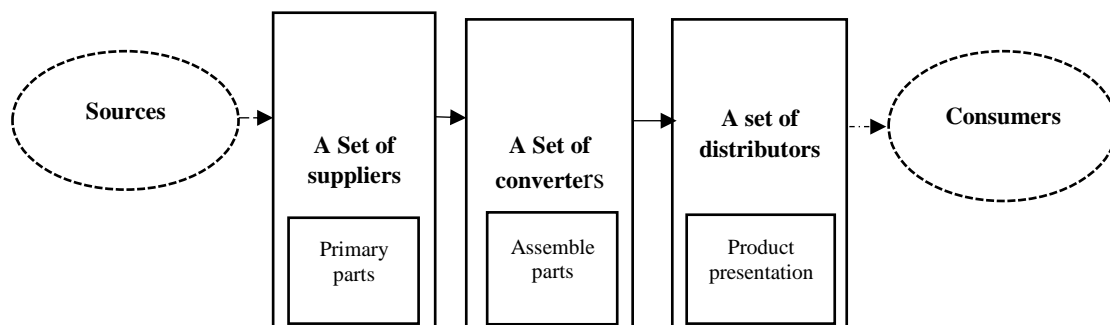

Figure 4. *Five-level one-way production supply chain evaluated by the research*

The second step involves building the structure of the production system, for this we need to determine the processes and sub-processes. According to the supply chain management process and the type of research supply chain, the structure of the research production system includes two sets (suppliers of primary parts and required production equipment). The third step is to determine the type of reliability calculation model. In this research, a combination of a

series-parallel model is used, as shown in Figure (5):

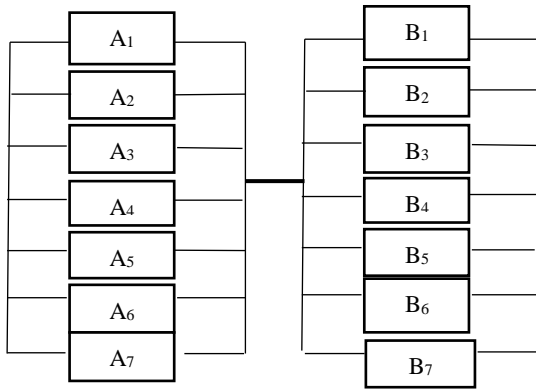

Figure 5. Series-parallel research system

That the components of group A are the required primary parts, which include (A_1 = parts, A_2 = screws, A_3 = wire, A_4 = cable, A_5 = board, A_6 = box, A_7 = ABS material) and the components of group B are required devices and equipment, which include (B_1 = injection machine, B_2 = spot welding machine, B_3 = press machine, B_4 = printing machine, B_5 = socket press machine, B_6 = wire segmentation machine and B_7 = shearing machine); And the reason for the implementation of the parallel-series system is that the components of part A are parallel to each other because, in a parallel system, only one of the parts needs to work so that the system can complete its task; And since the performance of all 8 suppliers are independent of each other; Therefore, these components are parallel to each other. It is the same for the components of part B; but in general, part A and part B are in series because, in a series system, all components must work for success. In other words, the failure of even one of the parts leads to failure or failure of the whole system, and therefore, if the parts that go from part A to part B are damaged, part B also fails and vice versa. For this reason, the research system is parallel-series. The fourth stage includes the stages of calculating the reliability of the research supply chain, which, as is clear from Figure (5), the overall research reliability system is a series system that consists of two parallel parts. Therefore, according to the life cycle of the equipment and parts and its operational sequence, the function of calculating the reliability of the research is as follows:

If the reliability of parts A and B are R_A and R_B , respectively, then the reliability of the system:

$$R_T = R_A R_B$$

(1)

$$R_A = R_{A_1} + R_{A_2} + \dots + R_{A_7} -$$

$$(R_{A_1} R_{A_2} \dots R_{A_7})$$

(2)

$$R_B = R_{B_1} + R_{B_2} + \dots + R_{B_7} -$$

$$(R_{B_1} R_{B_2} \dots R_{B_7}) \quad (3)$$

Also, in order to calculate the reliability of the first level of the research supply chain (R_A) of each of the suppliers related to each component (A_1 to A_7), the following steps have been taken to determine the best supplier in each of the sections (A_1 to A_7):

- 1- The average lifespan of each part was calculated; for this purpose, a period of three years was considered for all parts and those parts were tested in this period. Also, the total number of parts to be tested was determined.
- 2- The probability density of failure of each piece was calculated.
- 3- The failure rate of each part was determined.
- 4- Reliability (reliability) of each piece was calculated.
- 5- The instability of each part was determined.

In order to calculate these 5 steps, a series of reliability evaluation quantities have been used, as follows:

If in a system N_0 the number of parts of that system is considered and after time T some parts are healthy and some others are damaged, N_s is the consumption of the number of parts that remained healthy after the desired time has passed and N_f is the consumption of the number of parts that have passed after the They are damaged during the mentioned period. In this case, we can write:

$$N_0 = N_s + N_f \quad (4)$$

Therefore, with these conditions, in each time range during the test, the Failure probability density function is calculated as follows:

$$F(t) = \frac{1}{N_0} \frac{dN_f}{dt} = \frac{\Delta N_{f_t}(t)}{N_0 \Delta t} = \frac{\text{Change rate (number of failures in each time period)}}{\text{The total number of pieces per time period}} \quad (5)$$

Also, the failure rate function can be calculated as follows:

$$\lambda(t) = \frac{1}{N_0(t)} \frac{dN_f(t)}{dt} = \frac{1}{N_s} \frac{\Delta N_{f_t}(t)}{\Delta t} = \frac{\text{The number of failures in each time period}}{\text{Number of healthy parts}} \quad (6)$$

Therefore, the probability of parts survival can be calculated as follows:

$$R(t) = \frac{F(t)}{\lambda(t)} \quad (7)$$

Also, the instability of parts can be calculated as follows:

$$Q(t) = 1 - R(t) \quad (8)$$

In addition to the reliability of suppliers, in this research, the reliability of converters have also been discussed in order to accurately calculate the overall capability of the company's supply chain under study. Therefore, in order to calculate the reliability of the second level of the research supply chain (R_B), that is, the equipment and devices used (components B_1 to B_7), the following steps have been taken to determine the reliability of the converter:

1- The first step of calculating the reliability of machinery is to calculate and determine the type of probability density of each device, and considering that no matter how long the life of the part or device passes, it cannot be expected that the probability of failure will increase, therefore, from the exponential probability density function in this Research has been used. Because one of the important features of the exponential distribution non-memory. The concept of non-memory is that the probability density function does not change with the passage of time, in other words, the exponential distribution can be used for parts whose failure is not related to their working history. It is also used for times when breakdowns occur due to random causes and are not due to wear and tear. Exponential distribution is also used for many electrical components and components of industrial devices.

2- Equipment that has failed less than three times during its lifetime, by calculating the "Mean Time between Failures" (MTBF), the reliability of the relevant device can be calculated. This index measures the predictable time that elapses from the previous failure to the next failure of a mechanical or electronic system in normal operation. In fact, the MTBF index helps to predict how long each system will work and how much time is left until the next failure; And knowing when failure might occur is a major part of MTBF. This index is related to the field of parts and systems maintenance and is an important criterion for measuring safety performance and equipment design. MTBF is used in systems that are repairable. Failure in the definition of this parameter means failures that cause the system to stop completely and make it necessary to be repaired. Periodic repairs and system shutdowns that are carried out according to the maintenance plan (such as calibration or periodic replacement of parts) are not related to this index. In general, the bigger the MTBF, the longer the system works well and the later it crashes. Therefore, considering that the devices evaluated in the research have broken down less than three times. Therefore, this index has been calculated as follows:

$$MTBF = \frac{\text{The total operating time of the device}}{\text{The total number of device failures}} \quad (9)$$

3- The probability density function of each device was calculated as follows:

$$F(x) = \frac{1}{MTBF} \quad (10)$$

4- The reliability of each device was calculated as follows:

$$R(x) = 1 - F(x) \quad (11)$$

And thus, based on relations (4) to (11), reliability is calculated both in the supplier sector and in the converter sector and in general for the production supply chain of the company under study, and in addition, the superior supplier is also determined in each sector.

Supply chain evaluation model with supplier selection approach using NDEA

Since the company has seven separate supply chains, each of which includes eight

suppliers, therefore, in order to calculate the efficiency of each of these eight suppliers in each department, the data envelopment analysis model has been used, and considering that in classical models, the whole system is considered as a black box, but In many practical examples, the decision-making units or production processes themselves include subunits that are connected to each other in a network, in other words, the output of one subunit may be the

input of another subunit, and ultimately these interactions produce the final output of the system. Therefore, in many cases, it may be necessary to check the inefficiency of a decision maker in its sub-units, in which case we will need network models; Therefore, according to the selected indicators, the conceptual model of two-level network data coverage analysis to evaluate the performance of research suppliers will be according to Figure (6):

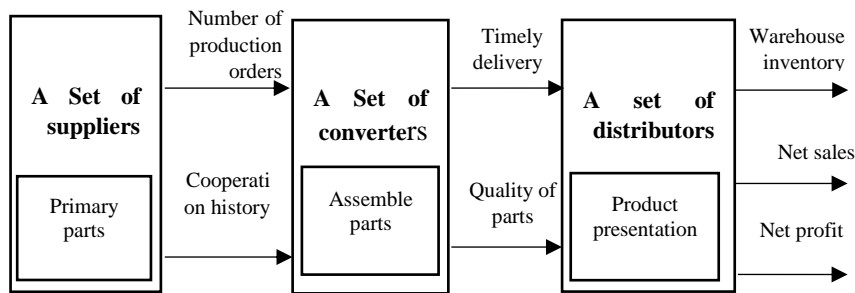

Figure 6. Conceptual model for evaluating the network efficiency of supply chains studied in the research

As it is clear from figure (6), the research model includes three parts of suppliers, converters and distributors, which in the first stage includes a part of the supply chain that is between the set of suppliers and the set of converters, and the second part of the supply chain also includes the set of converters And the set of distributors; And in each part, we

calculate the efficiency based on the two-stage data envelopment analysis model of Wang and Chin [45]; which is actually a model to achieve coordination in the entire supply chain and by converting this two-stage model to a one-stage model, it obtains cumulative efficiency according to the following figures:

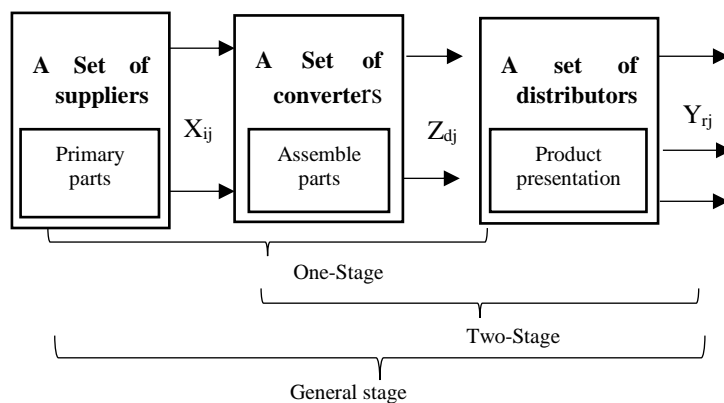

Figure 7. The Network Data Envelopment analysis model in this research

Then this model becomes a one-stage model according to Figure (8):

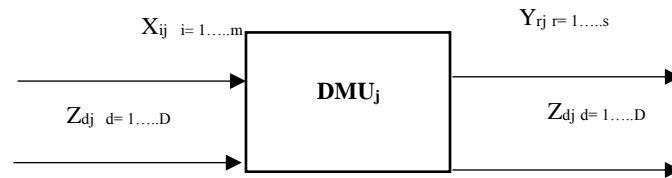

Figure 8. The process of converting two-stage to one-stage supply chain

And finally, the cumulative efficiency and the entire supply chain in Figure (8) was obtained according to the mathematical model (12):

$$\theta_0^* = \max \lambda_1 \sum_{d=1}^D \eta_d z_{d0} + \lambda_2 \sum_{r=1}^s u_r y_{r0} \quad (12)$$

s.t:

$$\begin{aligned} \lambda_1 \sum_{i=1}^m v_{ij} x_{i0} + \lambda_2 \sum_{d=1}^D \eta_d z_{d0} &= 1 \\ \sum_{d=1}^D \eta_d z_{d0} - \sum_{i=1}^m v_{ij} x_{i0} &\leq 0 \quad j=1, \dots, n \\ \sum_{r=1}^s u_r y_{r0} - \sum_{d=1}^D \eta_d z_{d0} &\leq 0 \quad j=1, \dots, n \\ \eta_d, u_r, v_i &\geq 0 \quad d=1, \dots, m, r \\ &= 1, \dots, s, i=1, \dots, m \end{aligned}$$

Which in this model Wang and Chin considered for relative weights $\lambda_1 \geq 0$ and $\lambda_2 \geq 0$ and the total efficiency is obtained as equation (13) where they defined $\lambda_1 + \lambda_2 = 1$.

$$\theta_0^* = \lambda_1 \theta_0^{1*} + \lambda_2 \theta_0^{2*} \quad (13)$$

Also, the partial efficiency of the first stage can be calculated through equation (14):

$$\theta_0^{1*} = \max \sum_{d=1}^D \eta_d z_{d0} \quad (14)$$

$$\text{s.t: } \sum_{i=1}^m v_{ij} x_{i0} = 1$$

$$\begin{aligned} (\lambda_1 - \lambda_2 \theta_0^*) \sum_{d=1}^D \eta_d z_{d0} + \lambda_2 \sum_{r=1}^s u_r y_{r0} &= \lambda_1 \theta_0^* \\ \sum_{d=1}^D \eta_d z_{d0} - \sum_{i=1}^m v_{ij} x_{i0} &\leq 0 \quad j=1, \dots, n \\ \sum_{r=1}^s u_r y_{r0} - \sum_{d=1}^D \eta_d z_{d0} &\leq 0 \quad j=1, \dots, n \\ \eta_d, u_r, v_i &\geq 0 \quad d=1, \dots, m, r \\ &= 1, \dots, s, i=1, \dots, m \end{aligned}$$

And the partial efficiency of the second stage can also be calculated through equation (15):

$$\theta_0^{2*} = \max \sum_{r=1}^s u_r y_{r0} \quad (15)$$

$$\text{s.t: } \sum_{d=1}^D \eta_d z_{d0} = 1$$

$$\begin{aligned} \lambda_2 \sum_{r=1}^s u_r y_{r0} - \lambda_1 \theta_0^* \sum_{i=1}^m v_{ij} x_{i0} &= \lambda_2 \theta_0^* - \lambda_1 \\ \sum_{d=1}^D \eta_d z_{d0} - \sum_{i=1}^m v_{ij} x_{i0} &\leq 0 \quad j=1, \dots, n \\ \sum_{r=1}^s u_r y_{r0} - \sum_{d=1}^D \eta_d z_{d0} &\leq 0 \quad j=1, \dots, n \end{aligned}$$

$$\eta_d, u_r, v_i \geq 0 \quad d=1, \dots, m, r=1, \dots, s, i=1, \dots, m$$

Research Findings

In order to conduct a case study, this research was conducted in an electrical appliance manufacturing company in Shiraz. Considering the extent of the company's activity in the field of product production and also considering that the company's main product is electronic equipment, therefore, it is necessary to evaluate the reliability and also the efficiency of the production supply chain because; Checking the reliability and failure records of the primary parts provided by the suppliers as well as evaluating the efficiency of the suppliers improves the overall performance of the supply chain, and on the other hand, the equipment and machinery of the company's production lines are being developed and upgraded every day, and the cost of their preventive maintenance is very high. For this reason, checking the failure records and calculating the reliability of the company's machines is also necessary.

Therefore, due to the increasing growth of the company in various and sensitive fields and the production of various supplies and equipment and the intensification of competition between various companies, the importance of the correct functioning of primary parts, equipment and machinery and the efficiency of its supply chains has become more necessary than before. This research has been to use the NDEA method on the one hand, and on the other hand, with reliability calculations, obtain the failure rate of the supplier's production product, which is a criterion for comparing the quality of the supplier's output or product; And finally, to rank the suppliers based on the product

failure rate, as well as to rank the suppliers based on their efficiency score with the NDEA method, so as to identify suppliers who are efficient and have a reliable product. Finally, the performance of both approaches in the field of supplier selection and effective supply chain management of the studied companies were investigated.

The results of supply chain evaluation and supplier selection using the "failure rate-based" approach

In order to calculate the reliability of the primary parts suppliers of the company (Part A, Figure (5)), taking into account the number of breakdowns and the health of the parts and according to relations (4) to (8), the reliability of each of the primary parts suppliers was determined and ranked, and the results It is given in table (4) as follows:

Table 4.

Calculation of failure probability density function, failure rate function, reliability, unreliability of primary parts supply chain

Suppliers of electronic parts (the first part of the research production supply chain)								
Suppliers	1	2	3	4	5	6	7	8
F(t)	.0134	.0112	.0334	.0167	.0334	.0667	.0334	.0223
$\lambda(t)$.0139	.0115	.0371	.0175	.0371	.0834	.0371	.0239
R(t)	.96	.97	.90	.95	.90	.79	.90	.93
Q(t)	.04	.03	.10	.05	.10	.21	.10	.07
Wire suppliers (the first part of research production supply chain)								
Suppliers	1	2	3	4	5	6	7	8
F(t)	.0134	.0344	.0477	.0677	.0334	.0463	.0334	.0267
$\lambda(t)$.0139	.0371	.0556	.0834	.0371	.0538	.0371	.0290
R(t)	.96	.90	.85	.79	.90	.86	.90	.92
Q(t)	.04	.10	.21	.10	.15	.14	.10	.08
Screw suppliers (the first part of research production supply chain)								
Suppliers	1	2	3	4	5	6	7	8
F(t)	.0250	.0139	.0134	.0112	.0378	.0159	.02	.0167
$\lambda(t)$.0271	.0145	.0139	.0115	.0167	.03031	.022	.0264
R(t)	.92	.958	.96	.97	.952	.91	.90	.63
Q(t)	.08	.05	.04	.03	.05	.09	.37	.10
Cable suppliers (the first part of research production supply chain)								
Suppliers	1	2	3	4	5	6	7	8
F(t)	.055	.0134	.0134	.1	.0223	.0223	.0834	.02
$\lambda(t)$.0056	.0139	.0145	.14	.0239	.0239	.11	.5
R(t)	.98	.96	.92	.71	.93	.93	.75	.40
Q(t)	.02	.04	.08	.29	.07	.07	.25	.60
Board suppliers (the first part of the research production supply chain)								
Suppliers	1	2	3	4	5	6	7	8
F(t)	.0112	.0334	.0834	.2	.0417	.0834	.0834	.0334
$\lambda(t)$.0115	.0371	.11	.5	.0477	.11	.11	.0371
R(t)	.97	.90	.75	.40	.87	.93	.75	.90
Q(t)	.03	.10	.25	.60	.13	.07	.25	.10
Box suppliers (the first part of the research production supply chain)								
Suppliers	1	2	3	4	5	6	7	8
F(t)	.0139	.0334	.0167	.0066	.0334	.05	.0083	.01111
$\lambda(t)$.0145	.0371	.0176	.0068	.0371	.59	.0086	.01150
R(t)	.95	.90	.94	.97	.90	.84	.965	.966
Q(t)	.05	.10	.06	.03	.10	.16	.04	.04
ABS material suppliers (the first part of the research production supply chain)								
Suppliers	1	2	3	4	5	6	7	8
F(t)	.0055	.0086	.019	.041	.011	.0086	.0019	.041
$\lambda(t)$.0057	.0088	.021	.047	.015	.0088	.0020	.047
R(t)	.96	.97	.90	.87	.73	.97	.95	.87
Q(t)	.04	.03	.10	.13	.27	.03	.05	.13

As it is clear from table number (4), the reliability and unreliability of each of the company's primary parts suppliers is known. Suppliers whose reliability is above 90% have high reliability and suppliers whose reliability is below 90% have low reliability. Also, based on the results and information of this table, company managers can have effective control and planning in line with the quality of their products and choose the best supplier, as well as predict the reliability of each of the suppliers, as well as the reliability of each received part. For example, according to the results of the table, it can be said about the reliability of suppliers of electronic components that except for one supplier,

most of the suppliers had a reliability of over 90%, and this indicates that the suppliers of electronic components have high reliability. Also, the best supplier is supplier 2, followed by supplier 1. Also, supplier 4 is in third place and supplier 8 is in fourth place. Also, Suppliers 3, 5, and 7 all have the same rank and are in fifth place; and the worst rank is related to supplier 6. Other suppliers in the supply chain can be analyzed in the same way. After obtaining the reliability results of the suppliers, the reliability of the company's machinery and equipment (section B of figure (5)) has been investigated according to relations (9) to (11), the results of which are given in table (5):

Table 5.

The reliability results of the company's equipment and devices under study

Device Name	Density Function Type	MTBF	F(x)	R(x)
Injection 1	Exponential Function	910	.0010	.999
Injection 2	Exponential Function	728	.0013	.998
Injection 3	Exponential Function	182	.0054	.994
Boiling point 1	Exponential Function	725	.0013	.998
Boiling point 2	Exponential Function	910	.0010	.999
Press 1	Exponential Function	710	.0014	.9986
Press 2	Exponential Function	728	.0013	.9987
Print 1	Exponential Function	910	.0010	.999
Print 2	Exponential Function	175	.0057	.994
Press socket 1	Exponential Function	925	.0010	.999
Press socket 2	Exponential Function	455	.0021	.997
Wire segmentation 1	Exponential Function	965	.0010	.999
wire segmentation 2	Exponential Function	5/483	.0020	.998
Big Shiring	Exponential Function	930	.0010	.999
Small Shiring	Exponential Function	465	.0021	.997

As it is clear from table (5), the reliability of all devices has been calculated and according to its results and the reliability of all devices above 90%, it can be said that all the devices of the company studied in the research have high and good reliability; and this has a great impact on the quality of their products. Following is the calculation of the overall reliability of the supply chain. In fact,

according to relations (1) to (3) and figure (5) given in the previous section, the overall reliability of the supply chain system can be obtained; In order to calculate, the suppliers who had superior reliability compared to other suppliers, as well as the devices and equipment whose reliability was also higher, these data are mentioned in table (6):

Table 6.

The data of the parallel-series supply chain system studied in the research

The data of the first part of the parallel-series system of supply chain						
R _{A1}	R ₂	R _{A3}	R _{A4}	R _{A5}	R _{A6}	R ₇
.97	.96	.97	.98	.97	.97	.97
The data of the second part of the parallel-series system of supply chain						
R _{B1}	R _{B2}	R _{B3}	R _{B4}	R _{B5}	R _{B6}	R _{B7}
.999	.999	.999	.999	.999	.999	.999

Now, in order to calculate the overall reliability of the supply chain according to relations (1) to (3), it has been done as follows:

$$R_T = 6 \times 6 = 36$$

$$R_A = .97 + .96 + .97 + .98 + .97 + .97 + .97 - (.97 \times .96 \times .97 \times .98 \times .97 \times .97 \times .97)$$

$$R_B = .999 + .999 + .9987 + .999 + .999 + .999 + .999 - (.999 \times .999 \times .9987 \times .999 \times .999 \times .999 \times .999)$$

Therefore, the overall reliability of the supply chain is equal to 36%.

The results of supply chain evaluation with supplier selection approach using NDEA

After determining the values of the input and output indicators (Figure (6)), by replacing these values in the models (12), (14) and (15) explained in the previous section, to solve the model and the efficiency of 7 supply chains investigated in the research were discussed, the description of the results is given in table (7):

Table 7.

The results of the network data overlay analysis model in order to evaluate the suppliers

Suppliers of electronic								
suppliers	1	2	3	4	5	6	7	8
θ_1^*	.6002	.2581	.6639	1	.7166	.5709	1	.5923
θ_2^*	.8525	1	1	.6867	.6464	.7744	1	.5846
θ	.4192	.4077	.7415	.8246	.6864	.6359	1	.5411
Wire suppliers								
suppliers	1	2	3	4	5	6	7	8
θ_1^*	1	.8712	.7144	.5919	.9231	1	.4909	.6951
θ_2^*	1	.8901	.6394	.7979	.5835	.5908	.4048	.6823
Screw suppliers								
Suppliers	1	2	3	4	5	6	7	8
θ_1^*	.3136	.3535	.4242	1	.7938	.2456	.5558	.3979
θ_2^*	.7440	.6333	1	1	.7570	.4438	.9331	1
θ	.3651	.4213	.6627	1	.6968	.2819	.6906	.5693
Cable suppliers								
suppliers	1	2	3	4	5	6	7	8
θ_1^*	.2712	.2929	.2522	1	.2953	.5556	1	1
θ_2^*	.7016	.1756	.2062	1	.4230	.4828	1	.6943
θ	.3471	.3976	.3846	1	.4587	.5249	.7158	.5502
Board suppliers								
suppliers	1	2	3	4	5	6	7	8
θ_1^*	.1823	.2917	1	1	.2669	1	.1946	.4630
θ_2^*	1	1	.5424	.3855	.7936	1	.8210	.8844
θ	.3084	.3978	.7712	.7477	.5407	1	.2889	.5924
Box suppliers								
suppliers	1	2	3	4	5	6	7	8
θ_1^*	1	.7456	1	.6903	1	.9180	1	.8800
θ_2^*	1	.1688	.1424	.1435	.8180	.9642	.1809	1

θ	1	.8543	.9408	.8160	.9610	.9402	.3927	.9334
ABS material suppliers								
suppliers	1	2	3	4	5	6	7	8
θ_1^*	.1119	.1148	.2585	.4286	.2500	.2609	.0684	1
θ_2^*	.5216	.5354	.6757	.4897	.3668	1	.5949	1
θ	.1655	.1723	.4108	.5342	.3086	.4133	.1146	1

As it is clear from table (7), the results show the efficiency of suppliers; which is a number between zero and one, and units below one are ineffective and efficient units have a score of one. The entire supply chain will be efficient when there is an efficient relationship between suppliers-converters and converters-distributors according to the conceptual model of the research supply chain (Figure (6)). Consider, for example, suppliers of electronic components; this issue is clearly visible in DMU7. Also, the efficiency of the entire supply chain, when the efficiency of each of the chains θ_1^* and θ_2^* are below one, it is definitely inefficient. Consider, for example, suppliers of electronic components; This can be seen in DMU₁, DMU₅, DMU₆, as well as DMU₂, DMU₃, DMU₄ related to suppliers of electronic components, although they are efficient at the

same level, but they are inefficient because the other two levels have an efficiency score below one. Other suppliers are analyzed in the same way. On the other hand, according to the information in table (7), the company managers can rank the suppliers and choose the best suppliers who are superior in terms of efficiency and improve the performance.

Also, to check the performance of both the data coverage analysis model and the evaluation model based on the failure rate in the 7 supply chains studied in the research, as well as to gain more knowledge about the statistical sample and usage approaches based on the reliability (results obtained according to table (4)) and usage approaches based on the NDEA (results obtained according to table (7)), a summary of the descriptive statistics of these approaches has been calculated; The results of which are given in table (8):

Table 8.

A summary of the descriptive statistics status of the NDEA evaluation model and the failure rate-based evaluation model

Descriptive statistics of the model based on failure rate	The supply chains studied in this research						
	Electronic Components	Wire	Screw	Cable	Board	Box	ABS material
Mean	.9125	.8850	12.2850	.8225	.8088	.9289	.9025
Median	.9150	.9000	.9550	.9250	.8850	.9450	.9250
Standard Deviation	.05701	.05127	3.220	.1973	.1832	.0455	.0815
Skewness	-1.531	-.623	1.828	-1.667	-1.887	-1.153	-1.507
Descriptive statistics of NDEA model	The supply chains studied in this research						
	Electronic Components	Wire	Screw	Cable	Board	Box	ABS material
Mean	.6570	.6986	.5859	.5473	.5808	.8548	.3899
Median	.6611	.6608	.6161	.4918	.5665	.9368	.3597
Standard Deviation	.2022	.1898	.2296	.2173	.2491	.1957	.2863
Skewness	.349	.196	.481	1.505	.417	-1.354	1.517

As it is clear from table (8), descriptive statistics of mean, median, standard deviation and skewness coefficient of each supply

chain are shown in both approaches used in this research. The average is the main central index that shows the balance point and the

center of gravity of the distribution and is a good index to show the centrality of the data. The median is the value that 50% of the sample data fall below and 50% are above. In general, the median is used as a measure of central tendency of distributions whose shape is asymmetric. The standard deviation is the most important dispersion parameter, which is obtained from the square root of the variance. This index indicates the average fluctuation of observations from their average, and the skewness coefficient indicates the left or right dispersion of the data compared to the normal distribution. According to the above table, as an example of the descriptive statistics of the parts supply chain in the NDEA model, as well as the model based on the failure rate, it is explained:

The mean performance of parts supply chain with the method of the NDEA model is .6570 which shows that the efficiency of the suppliers of this chain is about 65.7%, in other words, the investigated suppliers of this supply chain have obtained an mean of 65.7% return based on efficiency, also the mean performance of the parts suppliers with a model based on failure rate is equal to .9125 which shows that the quality of the parts produced by these suppliers is about 91.25%, in other words, the investigated suppliers of this supply chain have obtained an mean of 91.25% efficiency based on the quality of the parts, the mean for this supply chain with the NDEA model is equal to .6611 which shows that 50% of the data are lower than this value and 50% are higher than it, in other words, half of the studied suppliers had an efficiency of more than 61.1% and the rest had an efficiency of less than 61.1%. The average for this supply chain with a model based on the failure rate is .9150 this indicates that half of the studied suppliers had more than 91.5% quality efficiency of their parts and the rest had less than 91.5% efficiency. The value of the standard deviation for this supply chain with NDEA model is equal to .2020 which shows that the fluctuation medium of the average data for the supply chain is about 20.2% and the value of the standard deviation

for this supply chain with a model based on the failure rate is equal to .05701 which shows that the fluctuation medium of the average data for the supply chain is about 5.701%. The value of the skewness coefficient for this supply chain with the NDEA model is equal to .349 and it is in the range (-2 and 2), which indicates that the data is skewed to the right, and in terms of the skewness of this chain, it is normal and its distribution is symmetrical. Also, the value of the skewness coefficient with the model based on the failure rate is equal to -1.531 and is in the range of (-2 and 2), which indicates that the data is skewed to the left, and in terms of the skewness of this chain, it is normal and its distribution is symmetrical. Is. Other chains can be evaluated in the same way.

Conclusion

Organizations have realized that in order to survive in an environment where diversity, number and responsibility are high, they must be able to adapt themselves to future changes. Customer needs are constantly evolving and the product life cycle is getting shorter. Therefore, the supply chain must be able to respond to the market. The supply chain perspective is based on the fact that competition should exist between supply chains instead of between companies, and supply chain management is an approach to design, organize and implement these activities. Supply chain management integrates suppliers, converters and manufacturers, distributors and customers using information technology to meet customer expectations as effectively and efficiently as possible. As a result, companies can respond to the various demands of customers quickly and with high quality. As the competition has changed from companies to supply chains, therefore, supply chain management is considered as one of the important strategies for the success of competitors, and the supply chain in these companies is designed in such a way that; it empowers them to deliver their products to the final customers on time. Therefore, in this research, using two evaluation perspectives

based on failure rate and NDEA, each production supply chain under study was evaluated in order to have a suitable supply chain with the aim of meeting customer expectations, in addition to using the advantages of both methods. On the other hand, the basis of a successful supply chain is the selection of appropriate suppliers, because they are a key factor for improving the competitiveness of the organization. In fact, suppliers form a major part of the supply chain and can have a significant impact on the strategic success of the chain and specifically on the performance of the chain in terms of price, quality, technology and delivery. Therefore, the current research was conducted with the aim of providing a model for the reliability of the production supply chain as well as their efficiency, emphasizing the selection of suitable suppliers. For this purpose, the design of a one-way 5-level supply chain, the first and last level of which are located outside the border, was discussed in an electrical appliance manufacturing company in Shiraz, and then according to the type of reliability calculation system of the research, a combined system of series - parallel, the reliability of all seven supply chains studied in the research (electronic parts, wiring, screws, cables, boards, boxes and ABS materials) was calculated; In this regard, using the evaluation approach based on the failure rate, reliability was calculated both in the primary parts suppliers and in the converters (reliability check of each company's machinery for assembling parts) with the aim of choosing the best supplier; And the top suppliers in each supply chain were identified. Also, in order to evaluate the efficiency of supply chain management with the approach of selecting the best supplier, the data envelopment analysis model was also used in this research, and considering that to evaluate the performance of the production supply chain under study, it was necessary to provide a model that could, according to the nature The supply chain should pay attention to the interactions of input, intermediary and output data between suppliers, converters and distributors, and can simultaneously evaluate

the performance of the entire supply chain and its internal processes, Therefore, in this research, the network data envelopment analysis model was used. And the top suppliers were also identified with this model. Then, the performance of each assessment approach based on failure rate and NDEA was investigated, and the results showed; The models presented in this research are suitable models for evaluating the performance of the supply chain, because these models have the ability to consider the interactions of the chain components and indicators, and the results of the performance rating have a high resolution. Therefore, it is suggested that according to the confirmation of research indicators and supply chain accountability of manufacturing companies, managers and decision makers should pay attention to these indicators and models used in this research to improve performance. Also, in order to carry out further research in the future, the following items are suggested:

- 1- The problem of this research is planned in deterministic conditions. Therefore, it is suggested to plan the use of this research model in random conditions for further development in the future.
- 2- Using other algorithms to determine the reliability of failure factors, such as the Monte Carlo algorithm, and comparing its results with the results of the present study.
- 3- It is suggested to use the model obtained in this research to evaluate and reliability of suppliers in other industries.
- 4- It is suggested that the performance of the company studied in the research should be measured annually based on the models mentioned in the research, so that necessary measures can be taken to evaluate the performance and review the company to achieve efficiency and reliability at the optimal level.

References

- Adel. A., & Momeni, M. (2020). *Statistics and its application in management*, Tehran: Semat Publications; 23rd edition, second volume.
- Ayers, J.B. (2006). *Handbook of supply chain Management*, Auerbach Publications; 2nd

- edition, 1-640.
- Badiezadeh, T., Saen, R. F., & Samavati, T. (2018). Assessing sustainability of supply chains by double frontier network DEA: A big data approach. *Computers & Operations Research*, 98, 284-290. Doi:10.1016/j.cor.2017.06.003
- Banker, R. D., Charnes, A., & Cooper, W. W. (1984). Some models for estimating technical and scale inefficiencies in data envelopment analysis. *Management science*, 30(9), 1078-1092. Doi: <https://doi.org/10.1287/mnsc.30.9.1078>
- Barzegar, A., Ramezani, S., & Barzegar, H. (2022). Providing a Framework for Reliability Engineering and Maintenance Excellence (iREAM3) Based on Asset Management Principles. *Iranian Journal of Supply Chain Management*, 23 (73), 25-39. Dor: 20.1001.1.20089198.1400.23.73.2.0
- Charnes, A., Cooper, W. W., & Rhodes, E. (1978). Measuring the efficiency of decision making units. *European journal of operational research*, 2(6), 429-444. doi:10.1016/0377-2217(79)90229-7
- Chertab Jabari, S., Rahmani Yushanloui, K., Pasban, M., Yaqoub Alavi, M., & Ramezani, M. (2021). Evaluation of supply chain efficiency with a combined model of fuzzy data envelopment analysis and balanced scorecard in Tabriz automotive industry. *Iranian Journal of Supply Chain Management*, 23 (71), 33-46. Dor: 20.1001.1.20089198.1400.23.71.3.7
- Darvish Motevalli, M., & Ebrahimi, M. (2021). A New Model to Analyze the Efficiency of a Multilevel Drug Supply Network for Hospitals. *Journal of System Management*, 7(2), 59-81. doi: 10.30495/jsm.2021.1929000.1470
- Dehghan Khavari, S., & Derakhsh, S. (2021). An Innovative Throughout Conceptual Model Framework for Logistics Integration. *Iranian Journal of Supply Chain Management*, 23(70), 37-54. Dor: 20.1001.1.20089198.1400.23.70.3.5
- Ebrahimi, S. B., & Bagheri, E. (2022). Optimizing profit and reliability using a bi-objective mathematical model for oil and gas supply chain under disruption risks. *Computers & Industrial Engineering*, 163, 107849. Doi: <https://doi.org/10.1016/j.cie.2021.107849>
- Ebrahimi, N. 1998 *Index IEEE Transactions on Reliability* Vol. 47. Doi: 10.1109/TR.1998.756093
- Fakhrzad, M., Talebzadeh, P., & Goodarzi, F. (2019). The green Closed-Loop Supply Chain Network Design Considering Supply Centers Reliability under Uncertainty. *Journal of Industrial Engineering Research in Production Systems*, 7 (14), 179-197. Doi: 10.22084/ier.2019.15750.1734
- Farrell, M. J. (1957). The measurement of productive efficiency. *Journal of the royal statistical society: series A (General)*, 120(3), 253-281. Doi: <https://doi.org/10.2307/2343100>
- Golpîra, H., Babae Tirkolae, E., Taghavifard, M., & Zaheri, F. (2021). Multi-project Optimal Scheduling Considering Reliability and Quality within the Construction Supply Chain: A Hybrid Genetic Algorithm. *Industrial Management Studies*, 19(61), 65-93. Doi: 10/22054/jims.2021.4487.2354
- Ha, C., Jun, H. B., & Ok, C. (2018). A mathematical definition and basic structures for supply chain reliability: A procurement capability perspective. *Computers & Industrial Engineering*, 120, 334-345. Doi:10.1016/j.cie.2018.04.036
- Hendiani, S., Mahmoudi, A., & Liao, H. (2020). A multi-stage multi-criteria hierarchical decision-making approach for sustainable supplier selection. *Applied Soft Computing*, 94, 106456. Doi:10.1016/j.asoc.2020.106456
- Izadikhah, M., Azadi, M., Toloo, M., & Hussain, F. K. (2021). Sustainably resilient supply chains evaluation in public transport: A fuzzy chance-constrained two-stage DEA approach. *Applied Soft Computing*, 113, 107879. Doi: <https://doi.org/10.1016/j.asoc.2021.107879>
- Jahanshahloo, G.R., Hosseinzadeh Lotfi, F., & Nikomaram, H. (2016). *Data Envelopment Analysis and its Applications*. Second Edition Tehran: Islamic Azad University Publications Science and Research Branch.
- Jain, N., & Singh, A. R. (2020). Sustainable supplier selection under must-be criteria through Fuzzy inference system. *Journal of Cleaner Production*, 248, 119275. Doi:10.1016/j.jclepro.2019.11927
- Kalantary, M., & Saen, R. F. (2019). Assessing sustainability of supply chains: An inverse network dynamic DEA model. *Computers & Industrial Engineering*, 135, 1224-1238. Doi:10.1016/j.cie.2018.11.009
- Karbasian, M., & Tabatabai, L. (2014). *Familiarity with reliability*, Second Edition Tehran: Arkan Danesh Publications.

- Liao, C. N., & Kao, H. P. (2011). An integrated fuzzy TOPSIS and MCGP approach to supplier selection in supply chain management. *Expert Systems with Applications*, 38(9), 10803-10811. Doi: <https://doi.org/10.1016/j.eswa.2011.02.031>
- Majchráková, J., & Kremeňová, I. (2021). Transportation cost as an important element of a supplier selection process based on a multi-criteria decision analysis. *Transportation Research Procedia*, 55, 63-70. Doi:10.1016/j.trpro.2021.06.007
- Marzban, S., Shafiee, M., & Mozaffari, M. R. (2022). Four-Stage Supply Chain Design for Perishable Products and Evaluate it by Considering the Triple Dimensions of Sustainability. *Journal of System Management*, 8(4), 109-132. Doi: 10.30495/jsm.2022.1966734.1684
- Mortazavi, S., & Karbasian, M. (2019). Evaluation Reliability of Multistate Repairable Systems by Considering Common Cause Failure and Cascading Failure Using Dynamic Fault Tree and Bayesian Networks, *Sharif Journal of Industrial Engineering & Management*, 35 (1(1.1)), 91-104. Doi: 10.24200/j65.2019.7176.1736
- Naseri, P., & karimi, M. (2018). Estimate the reliability of the supplier in the disruption using Bayesian networks and fuzzy approach. *Modern Research in Decision Making*, 4 (1), 197-218. Dor: 20.1001.1.24766291.1398.4.1.9.3
- Nilforoushan, N., & Tahanian, A.(2017). Choose suppliers in the supply chain green (sustainable) required to purchase color surface marking Case Study: Department of Transport and Engineering Company Nik Andish. *Journal of Decisions and Operations Research*, 1 (2), 112-131, 2017. Doi: <https://doi.org/10.22105/dmor.2017.44886>
- Pryke, S. (Ed.). (2009). *Construction supply chain management: concepts and case studies* (Vol. 3). John Wiley & Sons.
- Sandtrov, H., Rausand, M. (1991). RCM closing the loop between Design Reliability and Operational Reliability Maintenance, publisher springer, 13-21. <https://link.springer.com/book/10.1007/978-94-011-2438-6#page=264>
- Sexton, T. R., & Lewis, H. F. (2003). Two-stage DEA: An application to major league baseball. *Journal of productivity analysis*, 19, 227-249. Doi: 10.2307/41770116
- Shahbandarzadeh, H., Behrouzi, Z. (2021). A Model for Evaluating the Performance of Banking Industry Service Supply Chain Under a Multi-Stage Process Using Data Enveloping Analysis. *Iranian Journal of Supply Chain Management*, 23 (71), 47-59. Dor: 20.1001.1.20089198.1400.23.71.4.8
- Shafiee, M., Saleh, H., & Ghaderi, M. (2021). Benchmarking in the Supply Chain Using Data Envelopment Analysis and System Dynamics Simulations. *Iranian Journal of Supply Chain Management*, 23 (70), 55-70. Dor: 20.1001.1.20089198.1400.23.70.4.6
- Shafiee, M., Akbarpoor, S., & Akhlaghi Nik, A. (2021). Evaluating the performance of Instrumentation equipment Borzouyeh petrochemical company suppliers using Data Envelopment Analysis and Nash Game Approach. *Iranian Journal of Supply Chain Management*, 23 (72). Dor: 20.1001.1.20089198.1400.23.72.4.0
- Shiripour, S., & Adib, A.(2019). Performance Evaluation of Supply Chains of Polyethylene Pipes Using Fuzzy Network Data Envelopment Analysis. *Industrial Management Studies*, 17(53), 247-294. Doi: <https://doi.org/10.22054/jims.2018.20141.1702>
- Stadtler, H. (2005). Supply chain management and advanced planning—basics, overview and challenges. *European journal of operational research*, 163(3), 575-588. Doi:10.1016/j.ejor.2004.03.001
- Tavakkol, P., Nahavandi, B., & Homayounfar, M. (2023). Analyzing the Drivers of Bullwhip Effect in Pharmaceutical Industry's Supply Chain. *Journal of System Management*, 9(1), 97-117. Doi: 10.30495/jsm.2022.1966147.1691
- Tseng, M. L., Chiang, J. H., & Lan, L. W. (2009). Selection of optimal supplier in supply chain management strategy with analytic network process and choquet integral. *Computers & Industrial Engineering*, 57(1), 330-340. Doi:10.1016/j.cie.2008.12.001
- Tone, K., & Tsutsui, M. (2009). Network DEA: A slacks-based measure approach. *European journal of operational research*, 197(1), 243-252. Doi:10.1016/j.ejor.2008.05.027
- Wan, S. P., Xu, G. L., & Dong, J. Y. (2017). Supplier selection using ANP and ELECTRE II in interval 2-tuple linguistic environment. *Information Sciences*, 385, 19-38. Doi:10.1016/j.ins.2016.12.032
- Wang, Y. M., & Chin, K. S. (2010). Some alternative DEA models for two-stage process.

- Expert Systems with Applications, 37(12), 8799-8808. Doi:10.1016/j.eswa.2010.06.024
- Yazdi, A. K., Wanke, P. F., Hanne, T., Abdi, F., & Sarfaraz, A. H. (2022). Supplier selection in the oil & gas industry: A comprehensive approach for Multi-Criteria Decision Analysis. *Socio-Economic Planning Sciences*, 79, 101142. Doi:10.1016/j.seps.2021.101142
- Yazdani, M., Chatterjee, P., Zavadskas, E. K., & Zolfani, S. H. (2017). Integrated QFD-MCDM framework for green supplier selection. *Journal of Cleaner Production*, 142, 3728-3740. Doi:10.1016/j.jclepro.2016.10.095
- Zhang, M., Chen, J., & Chang, S. H. (2020). An adaptive simulation analysis of reliability model for the system of supply chain based on partial differential equations. *Alexandria Engineering Journal*, 59(4), 2401-2407. Doi:10.1016/j.aej.2020.03.002
- Zhang, F., Chen, J., Zhu, Y., Zhuang, Z., & Li, J. (2018). Generalized score functions on interval-valued intuitionistic fuzzy sets with preference parameters for different types of decision makers and their application. *Applied Intelligence*, 48, 4084-4095. Doi:10.1007/s10489-018-1184-4.