



DOI: 10.71762/8v52-3x07

Research Paper

## Development of a Precise Mechanical Mechanism for Controlling Some Solenoid Valves

Peyman Heydari <sup>1\*</sup>, Reza Abbasi Kesbi <sup>2</sup>

<sup>1</sup>Department of Mechanics and Structures, Hamedan Technical & Vocational College (Mofateh), Hamedan, Iran

<sup>2</sup>MEMS & NEMS Laboratory, Faculty of New Sciences and Technologies, University of Tehran, Tehran, Iran

\*Email of the Corresponding Author: reza.abbasi@ut.ac.ir

Received: September 27, 2024; Accepted: December 12, 2024

### Abstract

Microcontrollers are small computers that can handle the processing of a small system. Today, microcontrollers are widely used and can be used in many cases. However, most microcontrollers are sensitive to industrial environments and three-phase electricity and suffer from environmental disturbances. In this paper, a mechanical system for controlling several pneumatic cylinders is presented and compared to an electronic system that is developed based on microcontrollers. Compared to the electronic system, the results show that this mechanical system has high accuracy and reproducibility in any environment. Therefore, this mechanism can be used in the industry instead of microcontrollers. In addition, this proposed system is not limited to several microswitches and can be used for more microswitches in different currents. It is enough to increase the diameter of the camshafts and the shaft length.

### Keywords

Mechanical Mechanism, Solenoid Valve, Pneumatic Cylinders, Microswitches

### 1. Introduction

Microcontroller is a programmable electronic chip that provides the components of a simple computer by connecting different parts in an electronic circuit [1]. Microcontrollers are used to build, control, and monitor all kinds of electronic systems, which are activated by programming microcontroller units and peripherals [2]. A microcontroller is a tiny computer that provides the components of a simple computer by collecting other electronic parts in a small space [3]. The structure and components of microcontrollers generally include CPU, memory, inputs and outputs, timer, analog to digital converter (ADC), and digital to analog converter (DCA) [4]. The CPU is the brain of the microcontroller, which is responsible for extracting and processing data and performing calculations and assigned tasks. Regarding memory, it should be said that each microcontroller comprises ROM, RAM, and flash, and all programs and data of the microcontroller are stored in this unit [5-7].

CPU usually uses this unit to store and access information. Input and output ports (I/O) are communication channels that all microcontrollers use to connect to peripheral devices, receive input, and display output [8]. For the timer, it should be said that every microcontroller needs one or more timers (counters) to generate pulses, measure frequency, create oscillations, etc., and control the timing and counting operations with their help [9-10].

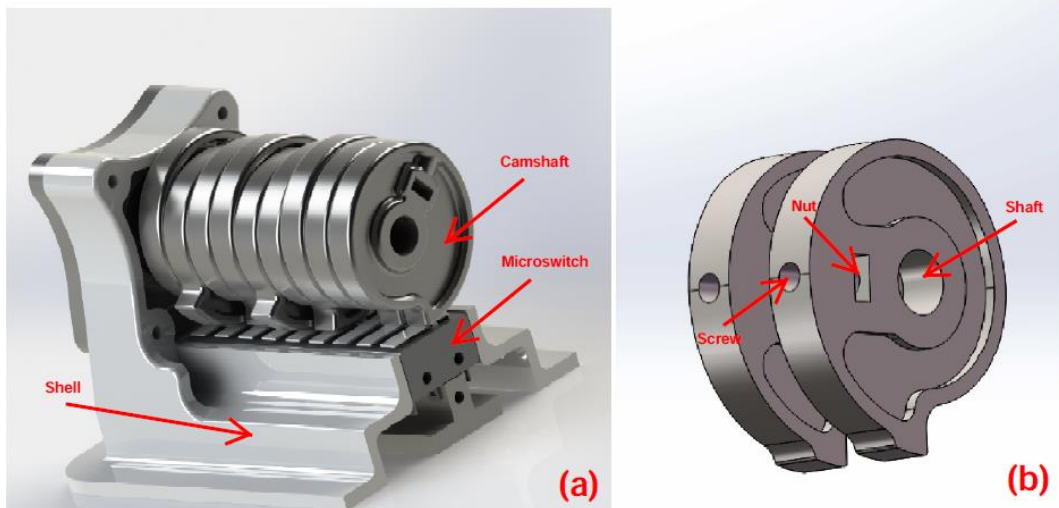

Figure 1. a) The cross-section of the proposed mechanical mechanism for controlling micro switches. b) The developed camshaft in the proposed mechanism

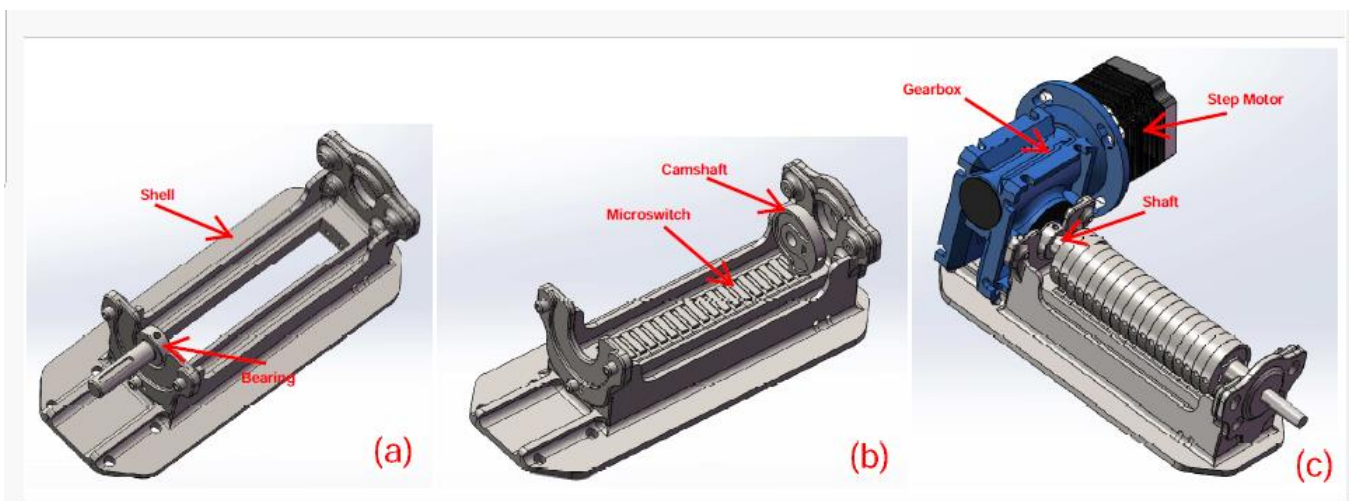

Figure 2. a) The shell and bearing of the presented mechanism. b) Placement of 18 micro switches and a camshaft on the shell. c) The developed mechanical system to control micro switches and solenoid valves that consist of the camshaft, micro switch, gearbox, and step motor

All the quantities used for measurement, control, and simulation are analog and continuous. Still, the microcontroller only understands the digital values that are converted with the help of analog-to-digital converter (ADC) and digital-to-analog converter (DCA). As a result, ADC and DCA converters are used to create a common language between micro and quantities such as heat, light, and so on [10-11]. The performance and speed of microcontrollers are very different from

microprocessors. The microprocessor is the microcontroller's CPU or brain, which performs all computational and logical operations on the data. The main difference between a microcontroller and a microprocessor is how they connect to external peripherals. Because all the peripherals used in the microcontroller are compressed together as a unit in the chip, larger samples must be used to connect the same equipment to the microprocessor. As a result, it is better to use a microcontroller instead of a microprocessor as much as possible. Because it is much cheaper to make any device with a microcontroller. In addition, in the construction of equipment with a microcontroller, less space is needed [12].

Most microcontrollers have many standard features because they all have a memory drive, input and output pins, and low power consumption. However, they differ in details, such as the number of bases, dimensions, final price, etc [13-14]. Types of microcontrollers are classified into the following groups based on the type of function and the circuit in which they are used: AVR microcontrollers, ARM microcontrollers, x-mega microcontrollers, PIC microcontrollers, 8051 microcontrollers [15]. Also, microcontrollers are divided into categories based on memory, architecture, bits, and instruction sets. Of course, it is suggested that AVR microcontrollers be used as much as possible. Atmel launched AVR microcontroller models. This model of microcontrollers from RISK and CISK architecture is used for their production. Unlike ARM microcontrollers, they are reasonably priced and easily found in the market [16]. As mentioned, the microcontroller is a tiny computer that simultaneously plays the role of the heart and brain of the set in every project and device! Therefore, currently, microcontrollers are used in most household and industrial appliances, such as lighting control systems, temperature and fire control systems, and command control systems in which measurement, storage, calculation, control, and information display are performed [17].

However, microcontrollers in the industrial environment suffer from noise, and they have many programming problems, which will cause problems [18]. It has been seen that microcontrollers, especially AVR microcontrollers, have many problems and frequent mistakes in industrial environments [19]. In this paper, at first, a microcontroller turns several microswitches on or off to control some solenoid valves. After working in a noisy environment for a few minutes, the electronic system experienced some problems. In addition, programming in this situation will have problems because a precise timer must be used. However, by the proposal and construction of this proposed system, the control of these solenoid valves is wholly separated from the microcontrollers. It is done with the help of this proposed mechanical system.

## **2. Material and Methods**

A cross-section of the proposed system is shown in Figure 1-a. First, a camshaft is designed in Figure 1-b. As can be seen, there are three holes in the camshaft: two are the same, and one is more significant. The larger hole is related to a shaft to hold 18 camshafts alongside. Two smaller holes are for a screw and nut to tighten the camshaft on the shaft. In this camshaft, an edge is designed to tap on a microswitch. Eighteen items are needed from this camshaft, which must be placed together.

In addition to this camshaft, a shell, as shown in Figure 2-a, b, is designed to place these micro switches and the camshaft together. As shown in this shell, a bearing is placed at the end of the shaft to prevent the camshafts from sticking out (Figure 2-a). Furthermore, there is a place to put the step motor and gearbox on the other side of this shell (Figure 2-c).

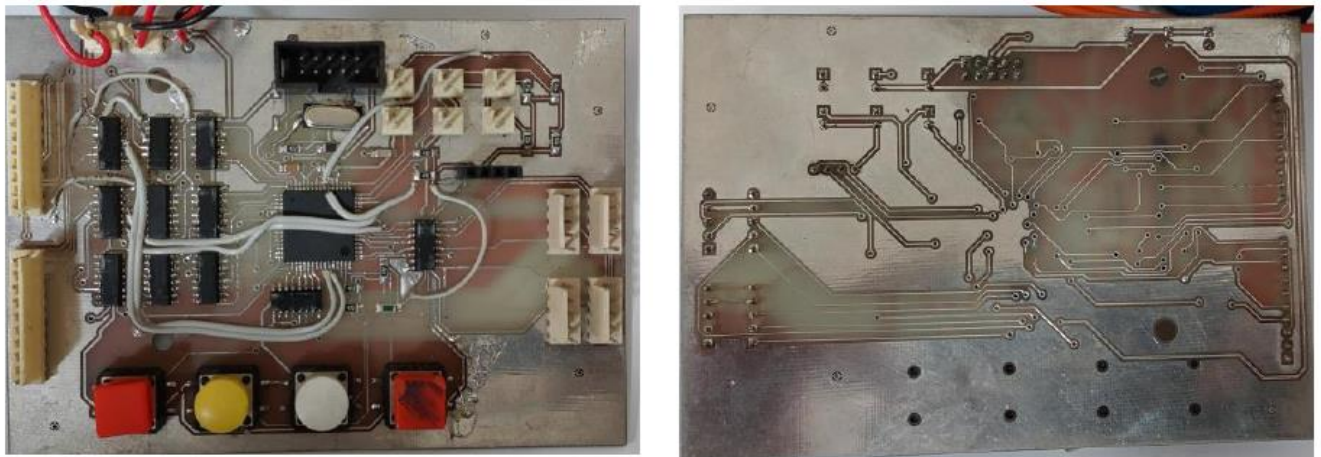

Figure 3. The developed electronic circuit to control the solenoid valve

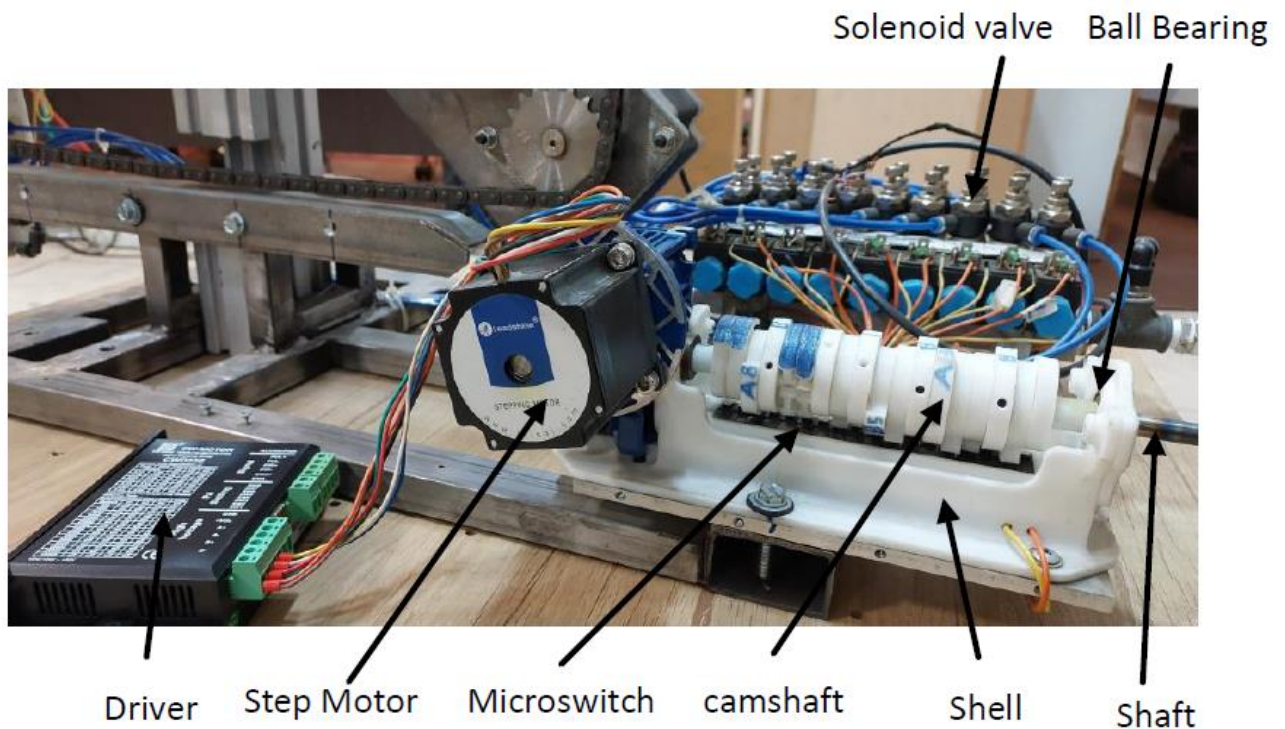

Figure 4. The developed mechanical system to control microswitches and solenoid valves. As can be seen, the components of the proposed system consist of a driver, step motor, microswitch, camshaft, shell, and shaft.

As Figure 2-b shows, 18 micro switches are used, and their input is connected to a power supply of 24 volts, and their output is connected to pneumatic cylinders. The 18 camshafts are placed in the shell, which shows its movement function. Figure 2-c shows all the camshafts, micro switches, and a stepper motor and gearbox. Using this mechanism and with the constant movement of the stepper motor, 18 microswitches can be controlled very precisely. Thus, the mechanism can move the microswitches by the constant movement of the stepper motor.

Additionally, an electronic circuit is developed for controlling the mechanism that works based on the microcontroller and also uln2003, as shown in Figure 3. The main program for the system is to use some timers on the microcontroller to set the time. Some buttons are defined for switching from one cycle in the program to another.

To implement the commands on the proposed electronic board shown in Figure 3, 18 commands are considered for a specific duration. The electronic board consists of microcontroller XMEGA 64 and twelve uln2003. The program is started by pressing one of the buttons, and all of the commands are performed in turn. However, there are some errors on *TIMER*, and over time the error increases. Consequently, the error accumulates, and after several cycles, the commands are never executed correctly [20]. Furthermore, the proposed circuit depends on temperature [21]. When the cycle is repeated several times, the temperature of the ULN2003 increases gradually, and the uln2003 is broken [22].

### 3. Results and Discussions

#### 3.1 The electronic proposed circuit

Each time the program is executed, 18 solenoid valves must be turned off and on at different times. None of the 18 solenoid valves turn on and off at fixed times and distances. First, these solenoid valves are active by a microcontroller. To control the solenoid valves, it is essential to use a specialized driver called the ULN2008 because every microcontroller has a limited current for its output. The maximum current is 20 mA in every pin as an output [23]. If a pin supplies more than this value, the pin will break. Thus, using a ULN2008 is mandatory for supplying the input voltage of the relay. It should be noted that the solenoid valve is an inductance, so a fly-back diode is needed to remove the turn current. If the current is more than a threshold in ULN2003, it will hurt the ULN2008. Every ULN2008 has an input with a low current and an output for every relay with a high current. On the other side, the solenoid valves need more current, so two input pins of the ULN2008 are used to turn on or off the solenoid valves to prevent possible damage to the ULN 2008 (Figure 6). The suggested circuit for starting with a microcontroller is shown in Figure 3. The used microcontroller is XMEGA 64, which has 64 input and output pins.

There are two ways to control solenoid valves, one of which is to give feedback through a microcontroller. The first method uses a *TIMER*, and the second method uses the input pins. There are some drawbacks to this electronic system. First, there are limited *TIMER*s in microcontrollers, and most have 3 *TIMER*s. For example, the Atmega 32 microcontroller has 3 *TIMER*s. One *TIMER* cannot be used to generate different times, and every *TIMER* can produce a special time. As a result, 18 *TIMER*s are needed for this proposed work. Although it can be used with a lower *TIMER* to set the time, the produced time is inaccurate, and there is a slight difference between this time and the real-time. If the little error can be neglected in the first cycle, the deviation will accumulate after repeating several cycles. Furthermore, using the *Delay* command, a subset of *TIMER*, can help decrease the number of programs. However, the *delay* command is less accurate than the timer, making it inappropriate for use in the system [24].

For the second method, which uses input pins instead of *TIMER*, the number of inputs and output are high, and the microcontroller never works properly. By having feedback for every microswitch, an input pin is needed. Thus, 36 pins of microcontrollers are used, increasing the price and bulkiness of

its program [25]. In addition, some microswitches do not work well and must be pressed again. In industrial and essential work, if a microswitch is not implemented on time, it will cause irreparable errors for the system and the collection [26]. It should be noted that there are many wires for assembling the input and connecting it to the microcontroller. Also, some mechanical structures are needed to connect the microswitch to the microcontroller as input. Thus, using 36 pins for output and input is not very practical.

Finally, there are some limitations to controlling the mechanism with a microcontroller. First, although the electronic system is accurate, it does not work well in ambient noise. The second disadvantage is that setting the timer is very complex [27-28]. Third, there are some limitations to the current, and when the solenoid valve has a current of more than 500 mA, the proposed circuit (Figure 3) cannot work, and the hardware has to be changed. However, the proposed mechanical system not only that is very accurate, but setting time is also very simple. Just get a hex key to lose them and set the camshafts in the appropriate position. Also, the mechanical system is not limited to the current. The only thing that works is an appropriate micro switch in the current to control the current.

### 3.2 The proposed mechanical method

A stepper motor of the *Leadshine* is used to start this proposed system. The start setup for the step motor consists of a 24V constant voltage for supplying voltage and generating a PWM wave with the help of PLC (Program logic control). The PLC has two pins for activation and changing the direction and a PWM pin. However, the pins supply a maximum current of 20 mA. Therefore, a driver is needed between the motor and PLC to make a pulse with an appropriate current for the step motor.

The minimum distance between two edges on two camshafts is determined so that the side micro switch is turned on after one switch is turned off. This minimum distance is 20 degrees for turning the stepper motor, and a micro switch is turned on. The order of turning on the micro switches is shown in Figure 5: \$A1\$, \$B1\$, \$A2\$, \$B2\$, \$A3\$, \$B3\$, \$A4\$, \$B4\$, \$A5\$, \$B5\$, \$A6\$, \$B6\$, \$A7\$, \$B7\$, \$A8\$, \$B8\$. As Figure 4 shows, the \$B\$ order is related to solenoid valves on one side, and the \$A\$ order is related to another side of valves.

As Figure 5 shows, these pulses can easily be shifted in the x-axis by losing camshafts using a hex key and putting it in a unique position of 360 degrees in the proposed mechanical mechanism. However, there are some limitations to setting the time using a microcontroller, and as mentioned earlier, an accurate timer is required for the test. If a *Timer* is used to make the pulse, there is an accumulative error caused by minimum error in every cycle. Because time is not very accurate, and every cycle has a minimum error. Therefore, it makes it difficult for users to turn on and off at specific times by the electronic board.

To activate the micro switches at a specific time, it is essential to configure them. Therefore, by loosening the screw that fixes them on the shaft, the camshaft is turned by hand so that the edge is at the right angle on the micro switch. If two microswitches want to be turned on at the same time, it is only necessary that their protrusions (edge) are in the same direction. When the stepper motor starts, the micro switches, which are in contact with the camshaft, are turned on at their own time, and others are turned off.

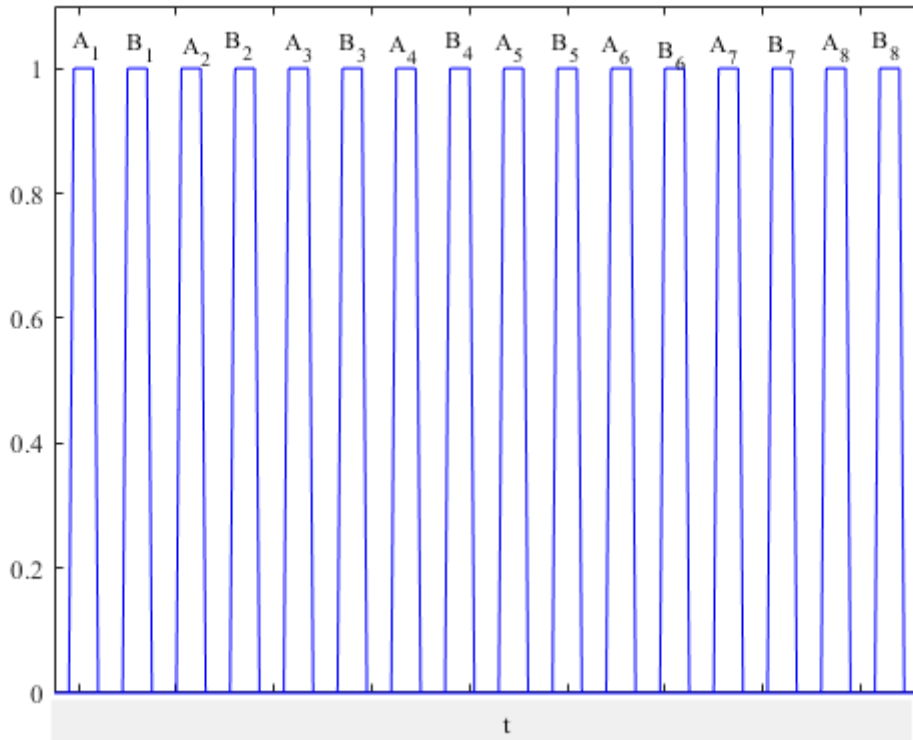

Figure 5. The proposed pulse for control of the mechanical mechanism

Thus, with the help of the proposed method in Figure 2, each solenoid valve can be controlled at its own time, and 18 micro switches can be turned on and off at suitable times. The shape of the proposed mechanical system is shown in Fig. 6 beside a more significant mechanism. The results show that this proposed mechanism can turn these electric valves off and on without sensitivity to the industrial environment and with much higher precision than microcontrollers. This method is very repeatable, and no errors are observed in consecutive repetitions.

The thickness of the camshafts is designed based on the number of controlled microswitches. The thickness of these camshafts is 1 cm; according to this thickness, 18 camshafts can be placed on the designed shaft. If the system rotates at a higher speed, the speed of turning off and on the microswitches will be higher. Therefore, there should be no conflict with this system. This system is not limited; if it is necessary to use more microswitches, the length of the shafts can be increased. By increasing the camshaft, the number of other microswitches can be added to the system. The price of the system is higher than electronic systems. However, the system proposed in this paper has higher accuracy and reliability than microcontroller systems.

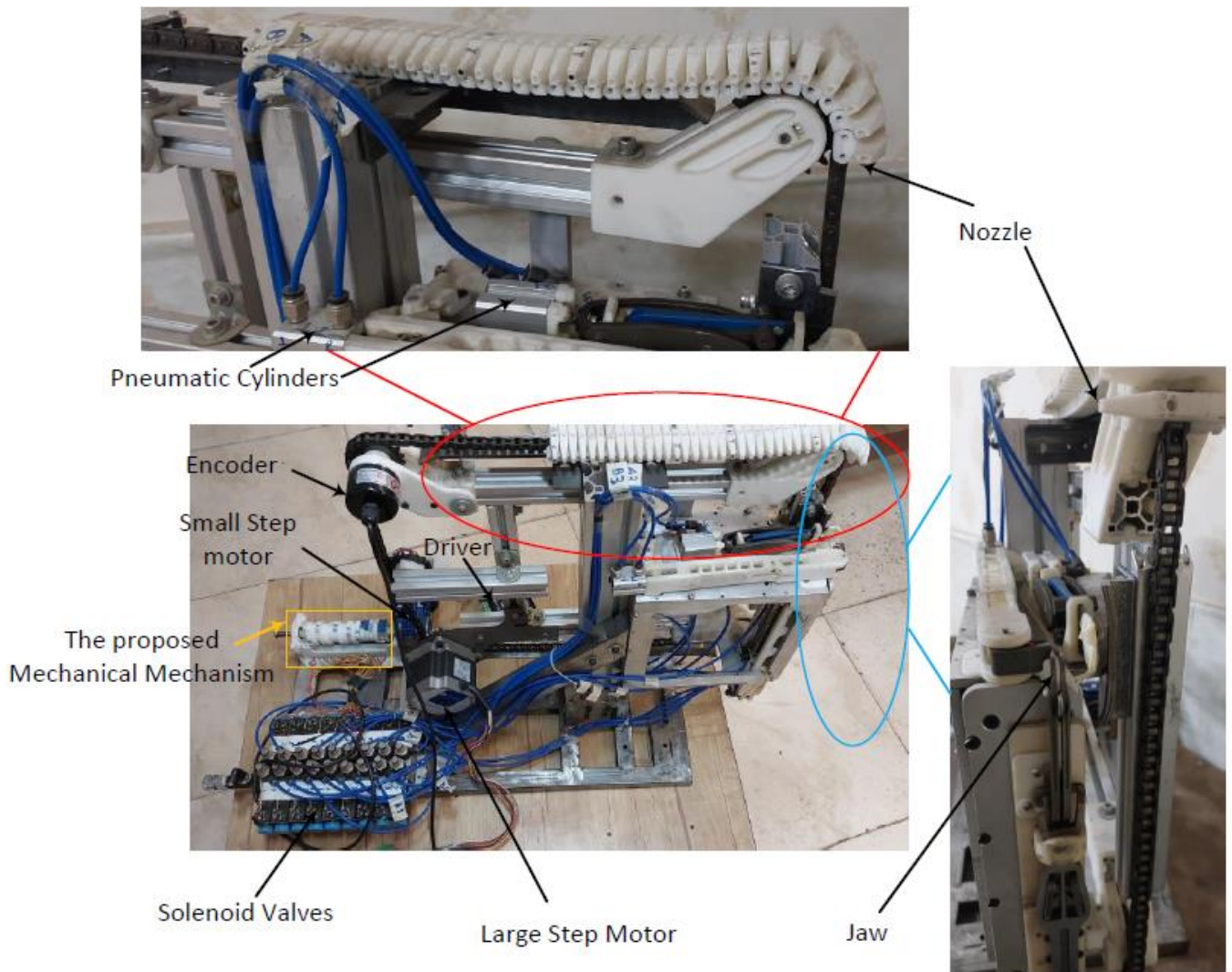

Figure 6. The developed system proposes to choose 35 colorful thirds

### 3.3 The mechanical application for the proposed system

It should be noted that the proposed mechanism in Figure 2 is used for controlling a jaw, as shown in Figure 6, and, as mentioned, the proposed mechanical system is turned by a small step motor at a constant velocity. The significant proposed mechanism shown in Fig. 6 is a system for taking colorful thirds in the textile industry comprising 35 colors. Every third is in a nozzle, and a nozzle is in front of a jaw by turning the large step motor.

As Figure 6 shows, there are two-step motors, an encoder, and some microswitches for the mechanism. Running the measurement setup by a microcontroller is not a reasonable method. Because there are many commands for motors and microswitches, especially encoders, errors will occur in the program. However, using programmable logic control (PLC) helps us turn two-step motors and one encoder without any problem in processing. Using PLC, any PWM with any frequency (1-150Kh) can be produced, while the microcontroller has some limitations. Additionally, there are sufficient inputs and outputs for microswitches.



#### 4. Conclusions

In this paper, a proposed mechanical mechanism is designed and developed to turn on and off 18 microswitches at different times to control solenoid valves and compared to an electronic board based on a microcontroller. The results showed that this mechanical system is more reliable and efficient than the proposed electronic systems. Also, this system is not limited to specific microswitches; the number of microswitches can be increased by increasing the shaft length. Furthermore, the current of the mechanical system is not limited to a specific current, and the microswitches can endure 10 A and more.

#### 5. References

- [1] Bolanakis, D.E. 2019. A survey of research in microcontroller education. *IEEE Revista Iberoamericana de Tecnologías del Aprendizaje*. 14(2):50-57. doi: 10.1109/RITA.2019.2922856.
- [2] Abbasi-Kesbi, R., Asadi, Z. and Nikfarjam, A. 2020. Developing a wireless sensor network based on a proposed algorithm for healthcare purposes. *Biomedical engineering letters*. 10(1):163-170. doi: 10.1007/s13534-019-00140-w.
- [3] Abbasi-Kesbi, R., Fathi, M. and Sajadi, S.Z. 2023. Movement examination of the lumbar spine using a developed wearable motion sensor. *Healthcare Technology Letters*. 10(6):122-132. doi: doi.org/10.1049/htl2.12063.
- [4] Prakash, A., Tyagi, P., Katiyar, A.K. and Dubey, S.K. 2023. A microcontroller-based compact device for measuring weak magnetic fields. *IEEE Sensors Journal*. 23(13):14339-14345. doi: 10.1109/JSEN.2023.3279366.
- [5] Abbasi-Kesbi, R., Memarzadeh-Tehran, H. and Deen, M.J. 2017. Technique to estimate human reaction time based on visual perception. *Healthcare technology letters*. 4(2):73-77. doi: 10.1049/htl.2016.0106.
- [6] Abbasi-Kesbi, R., Valipour, A. and Imani, K. 2018. Cardiorespiratory system monitoring using a developed acoustic sensor. *Healthcare technology letters*. 5(1):7-12. doi: 10.1049/htl.2017.0012.
- [7] Valipour, A. and Abbasi-Kesbi, R. 2017. May. A heartbeat and respiration rate sensor based on phonocardiogram for healthcare applications. In *2017 Iranian Conference on Electrical Engineering*. 45-48. doi: 10.1109/IranianCEE.2017.7985502.
- [8] Suprpto, Y., Jalaluddin, F., Moonlight, L.S. and Suharto, T.I. 2024. Microcontroller-Based Door Security System Design Using Fingerprint. *Journal Of Nesia Engineering Science*. 1(1):17-24. doi: 10.11591/jnesc.
- [9] Żyliński, M., Nassibi, A. and Mandić, D.P. 2023. Design and implementation of an atrial fibrillation detection algorithm on the ARM Cortex-M4 microcontroller. 23(17):7521. doi: 10.3390/s23177521.
- [10] Abbasi-Kesbi, R., Nikfarjam, A. and Memarzadeh-Tehran, H. 2016. A patient-centric sensory system for in-home rehabilitation. *IEEE Sensors Journal*. 17(2):524-533. doi: 10.1109/JSEN.2016.2631464.
- [11] Arachchige, K.G., Branch, P. and But, J. 2023. Evaluation of Correlation between Temperature of IoT Microcontroller Devices and Blockchain Energy Consumption in Wireless Sensor Networks. 23(14): 6265. doi: 10.3390/s23146265.

- [12] Abbasi-Kesbi, R. and Nikfarjam, A. 2018. A miniature sensor system for precise hand position monitoring. *IEEE Sensors Journal*. 18(6):2577-2584. doi: 10.1109/JSEN.2018.2795751.
- [13] Buonanno, L., Di Vita, D., Carminati, M. and Fiorini, C. 2020. A directional gamma-ray spectrometer with microcontroller-embedded machine learning. *IEEE Journal on Emerging and Selected Topics in Circuits and Systems*. 10(4):433-443. doi: 10.1109/JETCAS.2020.3029570.
- [14] Abbasi-Kesbi, R., Fathi, M., Najafi, M. and Nikfarjam, A. 2023. Assessment of human gait after total knee arthroplasty by dynamic time warping algorithm. *Healthcare Technology Letters*. 10(4):73-79. doi: 10.1049/htl2.12047.
- [15] Hercog, D. and Gergič, B. 2014. A flexible microcontroller-based data acquisition device. *Sensors*. 14(6): 9755-9775. doi: 10.3390/s140609755.
- [16] Akhavanhezaveh, A. and Abbasi-Kesbi, R. 2021. Diagnosing gait disorders based on angular variations of knee and ankle joints utilizing a developed wearable motion sensor. *Healthcare Technology Letters*. 8(5):118-127. doi: 10.1049/htl2.12015.
- [17] Roy, P., Saha, J., Dutta, N. and Chandra, S. 2018. Microcontroller based automated room light and fan controller. In *2018 Emerging Trends in Electronic Devices and Computational Techniques (EDCT, IEEE)*:1-4. doi: 10.1109/EDCT.2018.8405090.
- [18] Abbasi-Kesbi, R., Nikfarjam, A. and Akhavan Hezaveh, A. 2018. Developed wearable miniature sensor to diagnose initial perturbations of cardiorespiratory system. *Healthcare technology letters*. 5(6): 231-235. doi:10.1049/htl.2018.5027.
- [19] Chen, C.H., Lin, M.Y. and Liu, C.C. 2018. Edge computing gateway of the industrial internet of things using multiple collaborative microcontrollers. *IEEE Network*. 32(1):24-32. doi: 10.1109/MNET.2018.1700146.
- [20] Abbasi-Kesbi, R., Nikfarjam, A. and Nemati, M. 2020. Developed wireless sensor network to supervise the essential parameters in greenhouses for internet of things applications. *IET Circuits, Devices & Systems*. 14(8):1258-1264. doi:10.1049/iet-cds.2020.0085.
- [21] Anarghya, A., Rao, S.S., Herbert, M.A., Karanth, P.N. and Rao, N. 2019. Investigation of errors in microcontroller interface circuit for mutual inductance sensor. *Engineering Science and Technology, an International Journal*. 22(2):578-591. doi:10.1016/j.jestch.2018.11.011.
- [22] Kamajaya, L. and Fitri, M.A.S. 2023. Watch winder based on the internet of things. *Indonesian Journal of Electrical Engineering and Computer Science*. 30(2):721-729. doi:10.11591/ijeecs.v30.i2.pp721-729.
- [23] Santhosh, R., Sabareesh, S.U., Aswin, R. and Mahalakshmi, R. 2021. Hardware Design of PIC Microcontroller based Charge controller and MPPT for the Standalone PV-Battery charging system. In *2021 International Conference on Recent Trends on Electronics, Information, Communication & Technology (RTEICT, IEEE)*. doi:10.1109/RTEICT52294.2021.9573523.
- [24] Short, M. and Abugchem, F. 2017. A microcontroller-based adaptive model predictive control platform for process control applications. *Electronics*. 6(4): 88. doi:10.3390/electronics6040088.
- [25] Shriwastava, R., Dhote, N., Kadlag, S.S., Thakare, M.P., Kadam, D.P. and Khule, S.S. 2023. Performance analysis and improvement of a high-efficiency DCMLI based PMSM drive for electric vehicle using AVR microcontroller. *International Journal of Vehicle Noise and Vibration*. 19(3-4): 133-164. doi:10.1504/IJVNV.2023.136060.

- [26] Wolf, D., Alexandrov, V., Shatov, D., Rezkov, I., Trefilov, P. and Meshcheryakov, R. 2023. Development of a Firmware for Multicopter UAV Flight Controller Implemented on MCU MDR 32. Interactive Collaborative Robotics: 8th International Conference, ICR 2023, Baku, Azerbaijan. doi: 10.1007/978-3-031-43111-1\_31.
- [27] Kondaveeti, H.K., Kumaravelu, N.K., Vanambathina, S.D., Mathe, S.E. and Vappangi, S. 2021. A systematic literature review on prototyping with Arduino: Applications, challenges, advantages, and limitations. Computer Science Review. 40:100364. doi:10.1016/j.cosrev.2021.100364.
- [28] Lê, M.T., Wolinski, P. and Arbel, J. 2023. Efficient neural networks for tiny machine learning: A comprehensive review. doi: 10.48550/arXiv.2311.11883.