



## **Side Lobe Canceller Structure-Based Spatial Interference Cancellation and performance enhancement of the MIMO wireless systems**

**Navab Ghaedi <sup>1</sup>, Ali Jamshidi <sup>2\*</sup>, Behrad Mahboobi <sup>1</sup>, Ramezan Ali Sadeghzadeh <sup>3</sup>**

<sup>1</sup> Department of Electrical Engineering, Science and Research Branch, Islamic Azad University, Tehran, Iran

<sup>2</sup> Department of Electrical Engineering, Shiraz University, Shiraz, Iran

<sup>3</sup> Faculty of Electrical Engineering, K.N. Toosi University of Technology, Tehran, Iran.

Received: 21-Feb-2022, Revised: 01-Apr-2022, Accepted: 13-Apr-2022.

### **Abstract**

In some telecommunication systems, the signals received or sent by different antennas are combined with each other in a way that has the most benefit in a specific spatial direction. The signal sent or received by all antennas is the same and differs only in amplitude and phase. On the other hand, in some array systems, the transmitted signal is different from different antennas. Similarly, the receiver has a separate processor for each antenna. In MIMO systems where the transmitted signals from various antennas are different and each antenna has a separate receiver in reception, the physical distance between the different antennas must be greater than a certain value so that the paths of each antenna to the destination are independent. In this paper, considering this distance in practical systems, a number of auxiliary antennas are placed between the main antennas of the MIMO system. The main antenna together with its adjacent auxiliary antennas forms antenna assemblies. The function of auxiliary antennas is to eliminate co-channel interference by performing appropriate irradiation.

In this paper, the considered model is a channel with a feed rail that has a full order. For this channel model, different radiators such as MVDR, LCMV, GSC, ZF and maxSNR were investigated. And two different modes were considered for the transmitter. One of them is when the desired transmitter has one antenna and the other is when the desired transmitter has two antennas and uses Alamouti coding. In addition, both the state that the receiver is aware of the interference channel and the state that is not aware were examined. For each of these radiators,

---

\*Corresponding Authors Email:  
ali.jamshidiii2022@gmail.com

the output signal of the radiator was presented in order to decode the Alamouti coding. In addition, the LCMV radiator was examined under different conditions. In all these cases, the effect of the presence or absence of auxiliary antennas in eliminating all-channel interference was investigated. The simulations performed show the superiority of the performance of the methods proposed in this paper in the face of inter-channel interference.

**Keywords:** MIMO System; Alamouti Coding; Interference Cancellation; Side Lobe Canceller; Normalized LCMV Method.

---

## 1. INTRODUCTION

The development and commercial operation of fifth-generation systems to meet the high demand for data transmission is rapidly advancing in the next decade [1]. Fifth generation networks integrate with intelligent systems that include advanced signal processing [2], D2D device technology [3], IoT, edge computing [1], and additional wireless technologies [4] which have received a lot of attention in recent years [5]. The fifth generation (5G) cellular network is expected to support an increasing number of mobile devices with global access services [6]. Compared to the 4th generation, the 5th generation should achieve 1000 times the system capacity and spectral efficiency, energy efficiency, and data rate 10 times and the average cell efficiency 25 times [7]. To achieve these ambitious goals, advanced fifth-generation wireless technologies are being developed for greater spectral efficiency, higher energy efficiency, and denser cell deployment. Fig.1 shows some of these features of fifth generation systems [8].

The goals of the fifth generation are to increase data transfer speeds up to 20 Gbps (one Gigabit per second per user), increase the service capacity of network users (more users), reduce network latency and optimize power consumption in network equipment and users (such as Mobile phone), as well as

support higher speeds for moving users (such as a user riding a car on the freeway or high-speed train) [9]. In this generation, at least one million mobile broadband users per square kilometer must be able to connect to the network, and each user must be able to experience a minimum speed of 100 Mbps in the busiest state, which was not specified in the fourth generation standard. Reducing energy consumption is also a criterion that has been considered in this generation, and the transmitters and receivers of operators should enter the energy saving mode in low consumption hours and be activated quickly, which is not a criterion in the fourth generation. As a result, the fifth generation, for example, allows people to communicate as current media during peak hours via mobile phones. Also, its other operational goal is to improve support for car-to-car communication, ie IoT, at a lower cost, lower battery consumption and less latency than the fourth generation [9].

One of the important issues for the development of current and future wireless networks is the high density of wireless devices. With limited radio spectrum, many wireless users are required to share similar resources over time and / or frequency. As a result, the interference between devices becomes inevitable. In fact, such interactions are one of the main bottlenecks that limit the

capacity of the cellular network. Many efforts have been made to research interference management techniques. Thanks to the use of multiple antennas on MIMO systems, beam shaping has been shown to be an effective way to manage interference. That is, the transmitted signals are directed in a direction to minimize their negative effect on the receivers [7]. Array antennas have been introduced as one of the best options for use in the next generation of telecommunication receivers and transmitters due to the performance improvement they provide in telecommunication systems. The use of these antennas in the transmitter and receiver parts requires the use of appropriate processes in order to exploit the maximum capacity created. Radiation in fuzzy array systems, which was initially performed in analog form, can be considered the first practical use of array antennas. With advances in high-power digital processors, systems were found that used digital radiation in the receiver. Since the received signal from each antenna must be sampled, it is necessary to install a separate receiver for each antenna, which will increase the cost. Of course, the benefits of digital radiation in some applications justify the high cost. With the technology advancement and the need for telecommunication systems with high transmission rates along with good service quality, the idea of using arrays in the receiver and transmitter simultaneously and the use of proper processing has been highlighted. The processes performed in MIMO telecommunication systems, along with the channel nature of these systems, make it possible to achieve high rates in

telecommunication systems in malicious feedings.

In general, the goal of a telecommunication system is to achieve the desired data transmission rate with the least possible error. However, in wireless channels, despite the feeding phenomenon, achieving these two goals simultaneously is a major challenge [10].

In addition to increasing the bit rate and reducing the error rate, the multi-antenna system can also be used to increase the SNR, counteract all-channel interference, and thus increase the SINR. This can be achieved by using an array of adaptive antennas, also known as smart antennas. Using beam shaping, the antenna beam can be rotated in the desired direction or zeroed in the undesirable direction, for example in the direction of interference. Beam shaping is actually a kind of filtering in the field of space.

To form a beam in the receiver, the receiver must know the channel between the transmitter and each of the receiver antennas. Or to know the direction of signal input and the location of the receiver antennas. This information forms the direction vector. If the beam needs to be formed in the transmitter, the transmitter must also know the channel information between each of the transmitter antennas and the receiver antenna (or antennas). Therefore, there must be a mechanism for sending channel information to the transmitter to form a beam in the transmitter. In this respect, beam shaping at the receiver is preferable to beam shaping at the transmitter [10]. In [11] it is suggested that when the number of transmitter antennas

is large, the transmitter antennas should be divided into several subgroups and a time-frequency code should be considered for each subgroup and each subgroup should send its own data to increase data transmission rate in the system. Thus, if the receiver knows the desired signal channel and interference channel and the number of receiver antennas is more than the number of interfering antennas, the receiver can eliminate the interference. This method is called zero forcing (ZF).

In order to have spatial diversity and deal with co-frequency interference at the same time, the combination of space-time codes and beam shaping has been studied in many papers, including [18]. In [12-14], [19,20] the combination of beam shaping in the transmitter and block space-time code is investigated. To form a beam in the transmitter, the transmitter must also have channel information.

In a multi-antenna system with  $N_t$  transmitter antenna and  $N_r$  receiver antenna, the maximum available spatial diversification gain is  $N_t N_r$ . As the diversification gain increases, the system performance in the feed channel will be similar to the system performance in the AWGN channel. In practice, increasing the diversification gain too much will not be that much useful and will only increase the complexity of the recipient.

In [15], the allocation of power and beam formation in both the transmitter and the receiver is proposed for a multi-user MIMO system in order to maximize the SINR. For this purpose, the method presented in [16] has been used. The method presented in [16] for a system in which the desired transmitter

has multiple antennas in the presence of interference, obtains a receiver that will have a maximum SINR.

In [21], a beam-forming method is proposed in the transmitter to reduce interference for the case where the desired transmitter and the interference both use the Alamouti code. For this purpose, the receiver must know both the desired transmitter channel and the interference channel. Using this information, the receiver calculates a phase value and notifies the transmitter through a feedback channel. The transmitter shifts its second antenna signal by this amount of phase to reduce interference between the transmitters at the receiver.

## 2. SYSTEM MODEL

Consider a MIMO system consisting of a transmitter-receiver pair, similar to that shown in Fig.1. Note that to simplify the relationships, a structure with this number of users is provided, and this system can be generalized to any number of users. Without interrupting the whole issue, it is assumed that BS is the receiver. Both the transmitter and the receiver use an array antenna. The figure shows that there are two paths between the desired user and BS; Direct path and path reflected from the ground. To have a channel matrix with independent rows and columns, the two paths must be independent of each other. As mentioned previously, the distance between the receiving antennas must be greater than a certain value for path independence. In the BS receiver, because the antennas are mounted at a higher altitude than the ground, the distance between the antenna elements must be relatively large for the paths to be independent of each other.

Depending on the telecommunication system, this distance can be selected up to 15 times the wavelength. It is clear that under

these conditions, having an array with a large number of elements in the receiver is not possible [22].

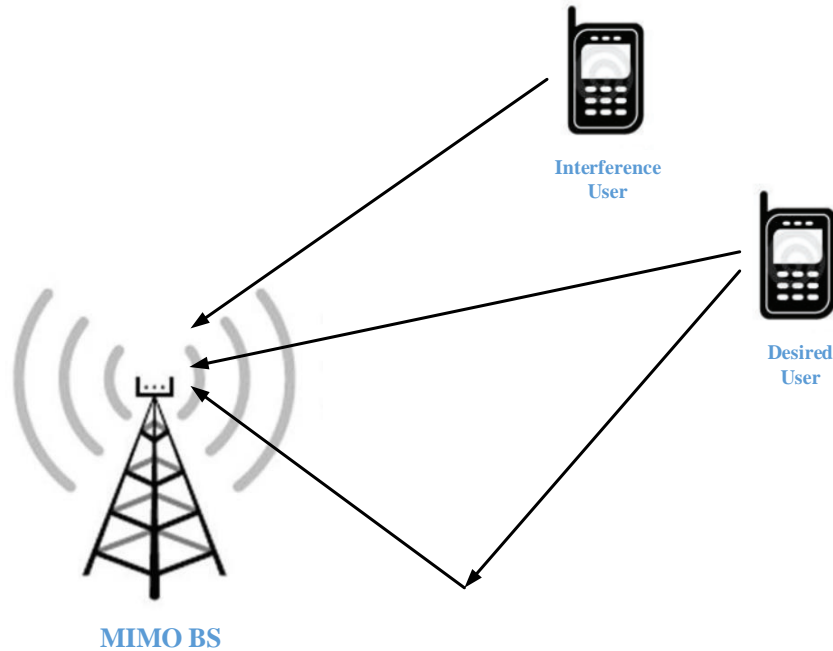

Fig.1. Display a MIMO system consisting of optimal transmitter and interference.

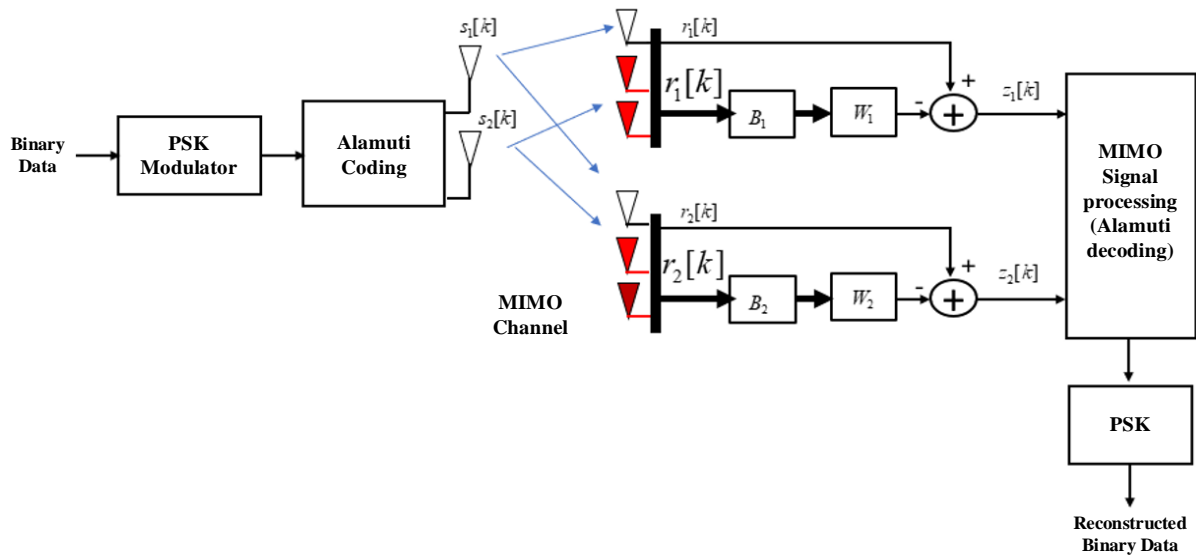

Fig.2. The proposed block diagram of signal processing in the MIMO system receiver.

In the method presented in this paper, the arrangement of the main antennas of the MIMO system receiver is determined by considering the limitations in the distance between the elements. In this paper, a uniform linear array structure is used for the array on both the transmitter and receiver sides. After taking into account all the limitations of the system, the arrangement of the array antennas in the receiver is determined, a number of auxiliary antennas are placed in the distance between the main antennas. These antennas can be of the same type as the main antennas or different from them. A main antenna together with adjacent auxiliary antennas form a set of antennas. In each antenna assembly, radiation is received spatially on the receiver side to eliminate the interference signal, and the filtered signal is given according to the next processing to perform MIMO processing on it.

The described receiver structure is shown in Fig.2. In this figure, the antennas marked in black are the main antennas. The antennas shown in red are auxiliary antennas. The signal received from the auxiliary antennas and the main antenna enters the radiation section. First, using the blocking technique, the component related to the desired signal is removed from the signal of the auxiliary antennas. Then, using the weights obtained by the adaptive algorithm, the signals of different antennas are multiplied by different mixed weights and added together. This signal is subtracted from the main antenna signal and the resulting signal, as one of the signals used in MIMO processing, enters the next processing class.

It is important to note that the signals of each antenna set are combined and one signal

for each set enters the MIMO process. Therefore, the distance between the centre of each set and the centre of the adjacent set will be considered as the distance between the antennas of the MIMO system. Consequently, this distance is equal to the distance between the main elements marked in black. Therefore, all restrictions that must be placed to the distance between adjacent elements in the MIMO system must be true on the distance between the main elements. It should be noted that the method presented in this chapter is only to add auxiliary elements on the receiver side and on the transmitter side of the used antennas for MIMO processing.

Assume that the MIMO system uses the number of  $N_t$  antennas on the transmitter side and the number  $N_r = n_r N_{si}$  on the receiver side, where  $n_r$  is the total number of antenna sets and  $N_{si}$  is the number of antennas in the  $i$  set. After performing digital sampling on the receiver, which is synchronized with the signal sent from the sender, the received signal vector  $X(n) \in \mathbb{C}^{N_r \times 1}$  in the  $n^{th}$  time slot on the receiver will be as follows:

$$x(n) = \sum_{m=1}^M \sum_{l=1}^{L_m} \{k_{lm} a_r(\theta_{lm}) a_t(\theta_{lm})^T S_m(n)\} + n(n) \quad (1)$$

In the above formula, the orientation vectors of receiver and transmitter are as follows:

$$a_r(\theta_{r,lm}) = \frac{1}{\sqrt{N_r}} [1, \exp\left(-j \frac{2\pi d_r}{\lambda} \sin \theta_{r,lm}\right)] \quad (2)$$

$$\begin{aligned}
& , \dots, \exp \left( -j \frac{2\pi d_r}{\lambda} (N_r \right. \\
& \quad \left. - 1) \sin \theta_{r,lm} \right) \Big]^T \\
& a_t(\theta_{t,lm}) \\
& = \frac{1}{\sqrt{N_t}} \left[ 1, \exp \left( j \frac{2\pi d_t}{\lambda} \sin \theta_{t,lm} \right), \right. \\
& \quad \left. \dots, \exp \left( j \frac{2\pi d_t}{\lambda} (N_t - 1) \sin \theta_{t,lm} \right) \right]^T
\end{aligned} \quad (3)$$

$M$  is the number of separate sources in the environment and  $L_m$  is the number of paths between the source  $m$  and the receiver.  $k_{1m}$  is the attenuation coefficient that models the effects of the environment on the transmitted signal of the  $m$ th source from the  $l$ th path.  $a_r(\theta_{lm})$  and  $a_t(\theta_{lm})$  represent the directional vectors on the receiver side and on the transmitter side, respectively, which depend on the angle of transmission and reception of the wave from the  $m$ th source and in the  $l$ th path.  $\mathbf{S}_m(n)$  is the symbol vector sent from the  $m$ th source in the  $n$  time interval. The vector  $\mathbf{n}(n)$  is the noise vector in the receiver which is a randomized white Gaussian process with variance  $\sigma^2$ . This noise is independent of the transmitted signals and the noise of each element is considered independent of the other elements. Therefore, for this random variable, the variance vector is defined and the covariance matrix is not defined. If the covariance matrix has to be considered for this random variable, it will be a diagonal matrix whose diagonal values are the members of the vector  $\sigma^2$ .

In the continuation of this section, the matrix of channel coefficients related to the desired signal with  $H_d$  is shown and the matrix of channel coefficients related to the  $j$

source of interference with  $H_{Ii}$  is displayed. According to the relationship that existed for the received signal in the receiver, the matrix of the desired signal channel coefficients will be defined as follows:

$$\mathbf{H}_d \triangleq \sum_{l=1}^{L_1} \{k_{l1} a_r(\theta_{r,l1}) a_t(\theta_{t,l1})^T\} \quad (4)$$

Note that without disturbing the whole problem, the first signal is considered the desired signal and the other signals are assumed to interfere. The channel coefficient matrix for other signals is obtained in a similar way. By performing these definitions, the received signal vector  $\mathbf{x}(n)$  is displayed as follows:

$$\begin{aligned}
\mathbf{x}(n) = & \mathbf{H}_d \mathbf{s}_d(n) + \sum_{m=2}^M \mathbf{H}_{1m} \mathbf{s}_m(n) \\
& + \mathbf{n}(n)
\end{aligned} \quad (5)$$

Note that  $\mathbf{S}_d(n)$  is the vector of the signal transmitted from the desired source in the time interval  $n$ . In order to take advantage of multi-path in MIMO systems, different paths between different antennas must have independent feedings. Therefore, it is assumed that the distance between the antennas is not less than the reference distance, which depends on the system configuration.

In the system presented in this section, due to the large distance between the elements on the receiver side, a number of additional antennas are placed between the main elements of the MIMO system. Each main antenna together with adjacent auxiliary antennas form a set of antennas. The radiation weights in each antenna set are determined in such a way that the effect of the interfering

signals on the final signal from each antenna set is as small as possible [22].

Assume that the MIMO system uses the number of  $N_t$  antennas on the transmitter side and the number  $N_r = n_r N_{si}$  on the receiver side, where  $n_r$  is the total number of antenna sets and  $N_{si}$  is the number of antennas in the  $i$  set. Next, the number of elements in the antenna assemblies are assumed to be equal to each other. The received vector signal in the  $i$  subset will be as follows:

$$\begin{aligned} x_i(n) = & \sum_{m=1}^M \sum_{l=1}^{L_m} \{k_{lm} s_m(n) a_{ri}(\theta_{r,lm}) a_t(\theta_{t,lm})^T\} (6) \\ & + n_i(n); \quad i = 1, \dots, n_r \end{aligned}$$

where  $a_{ri} \in \mathbb{C}^{N_{si} \times 1}$  is the signal orientation vectors in the  $i^{th}$  set, which are defined as follows:

$$\begin{aligned} a_{ri}(\theta_{r,lm}) & = \frac{1}{\sqrt{N_{si}}} [1, \exp(-j \frac{2\pi d_r}{\lambda} \sin \theta_{r,lm}), \\ & \dots, \exp(-j \frac{2\pi d_r}{\lambda} (N_{si} \\ & - 1) \sin \theta_{r,lm})]^T \end{aligned} \quad (7)$$

In these relations,  $d_r$  is the distance between the antennas, including the auxiliary elements; this means that the distance between the two adjacent antennas in the receiver in each set is equal to  $d_r$ .

As shown in the receiver structure in Fig.2, the received signals in each antenna set first pass through the blocking unit. The task of this section is to remove the components related to the desired signal from the auxiliary path signals. If there is a favourable signal in the auxiliary path, the optimal weights obtained for the radiation will be

such that instead of the radiator is able to eliminate the interfering signal, it will eliminate the desired signal. The output vector of the blocking unit in time interval  $n$  will be as follows:

$$\mathbf{y}_i(n) = \mathbf{B} \mathbf{x}_i(n) \quad (8)$$

where  $B \in \mathbb{L}^{N_{si} \times N_{si}}$  is the blocking matrix which is obtained as follows:

$$\mathbf{B} = \mathbf{I}_{N_{si} \times N_{si}} - \mathbf{A}_d (\mathbf{A}_d^H \mathbf{A}_d)^{-1} \mathbf{A}_d^H \quad (9)$$

where  $A_d$  is the vector signal matrix of the desired signal at the receiver. Assume that the number of paths from the desired signal source to the receiver is  $p$ . Therefore, the matrix of directional vectors related to the desired signal will be as follows:

$$\mathbf{A}_d = [\hat{\mathbf{a}}_r(\theta_{11}) \quad \dots \quad \hat{\mathbf{a}}_r(\theta_{1p})]^T \quad (10)$$

where  $i = 1, p, \hat{\mathbf{a}}_r(\theta_{1i}) \in \mathbb{C}^{N_{si} \times 1}$  is the direction vector for each antenna set in the receiver. Therefore, the relation 0 will always be established and the desired signal will be removed from the output signal of the blocking process:

$$\mathbf{B}^H \mathbf{A}_d = \mathbf{0} \quad (11)$$

See reference [57] for more information on matrix  $B$ . The  $y_i; i = 1, \dots, n_r$  signal is first weighted by the radiation vectors  $w_i$ . Then, the signal from the main path signal is reduced. The result of subtracting the auxiliary path from the main path is represented by  $e_i(n); i = 1, \dots, n_r$  and sent to the next classes for MIMO processing. This signal will be as follows:

$$e_i(n) = m_i(n) - \mathbf{w}_i^H \mathbf{y}_i(n) \quad (12)$$



$m_i(n)$  is the signal received from the main antenna in the  $i^{th}$  set and in the  $n^{th}$  time interval.

$w_i$  radiation weights are obtained by minimizing the mean square of the signal  $e_i$ :

$$\mathbf{w}_i = \arg \min_{\mathbf{w}_i} E \left\{ |e_i|^2 \right\} = E \left\{ \left| m_i(n) - \mathbf{w}_i^H \mathbf{y}_i(n) \right|^2 \right\} \quad (13)$$

The operator  $E\{o\}$  represents the statistical mean operator. The relationship expressed for finding the optimal irradiation weights in Equation 0 is similar to the one for finding the optimal weights in lateral petal removal systems.

It is possible to use the relation that exists to answer the optimal weights package and obtain the optimal value of  $w_i; i = 1, \dots, n_r$ , but due to the fact that the calculation of optimal weights has a high computational volume, the proposed method uses adaptive algorithms to find these weights. The LMS algorithm has been widely used in practical systems due to its simplicity of implementation and low computation rate for updating weights [22].

### 3. PROPOSED IRRADIATION METHODS TO ELIMINATE INTERFERENCE IN THE ALAMUT CODE RECEIVER

When the transmitter has two antennas, the Alamouti code is one of the most important and widely used space-time codes. In this section, assuming that the desired transmitter uses the Alamouti code and in the presence of interference, the methods of beam formation in the receiver with and without the help of

auxiliary antennas in the receiver are investigated.

If the channel between the first transmitter antenna and the receiver antennas with  $[h_{11} \ h_{12} \ \dots \ h_{1N_r}]$ , the channel between the second transmitter antenna with the receiver antennas with  $[h_{21} \ h_{22} \ \dots \ h_{2N_r}]$  and the signal received in  $N_r$  the receiver antenna in the first time range with  $[r_{11} \ r_{12} \ \dots \ r_{1N_r}]$  and the signal received in the second time period with  $[r_{21} \ r_{22} \ \dots \ r_{2N_r}]$  are given; The Alamut code receiver works to decode the  $s_1$  and  $s_2$  symbols as follows:

$$\tilde{s}_1 = \sum_{i=1}^{N_r} h_{1i}^* r_{1i} + h_{2i} r_{2i}^* \quad (14)$$

$$\tilde{s}_2 = \sum_{i=1}^{N_r} h_{2i}^* r_{1i} - h_{1i} r_{2i}^* \quad (15)$$

The optimal receiver to decode the symbol  $s_1$  selects point  $a_i$  from all points of the modulation system if and only if:

$$\begin{aligned} & \left( \sum_{j=1}^{N_r} (|h_{1i}|^2 + |h_{2i}|^2) - 1 \right) |a_i|^2 \\ & + d^2(a_i, \tilde{s}_1) \\ & \leq \left( \sum_{j=1}^{N_r} (|h_{1i}|^2 \right. \\ & \left. + |h_{2i}|^2) - 1 \right) |a_k|^2 \\ & + d^2(a_k, \tilde{s}_1) \quad \forall k \\ & \neq i, \end{aligned} \quad (16)$$

In the above relation  $d^2(x, y)$  is the square of the Euclidean distance of the two

signals  $x$  and  $y$ , which is obtained from the following relation:

$$d^2(x, y) = (x - y)(x^* - y^*) \quad (17)$$

If the modulation used in the transmitter is PSK, the energy of all the symbols of the modulation system points is equal and the optimal decision-making criterion for decoding the symbol  $s_1$  will be as follows:

$$d^2(a_i, \tilde{s}_1) \leq d^2(a_k, \tilde{s}_1) \quad \forall k \neq i \quad (18)$$

Similarly, the optimal receiver to receive the symbol  $s_2$  from all points in the modulation system selects point  $a_i$  if and only if:

$$\begin{aligned} & \left( \sum_{j=1}^{N_r} (|h_{1i}|^2 + |h_{2i}|^2) - 1 \right) |a_i|^2 \\ & + d^2(a_i, \tilde{s}_2) \\ & \leq \left( \sum_{j=1}^{N_r} (|h_{1i}|^2 \right. \\ & \left. + |h_{2i}|^2) - 1 \right) |a_k|^2 \\ & + d^2(a_k, \tilde{s}_2) \quad \forall k \end{aligned} \quad (19)$$

And for PSK modulation selects point  $a_i$  if and only if:

$$d^2(a_i, \tilde{s}_2) \leq d^2(a_k, \tilde{s}_2) \quad \forall k \neq i \quad (20)$$

Beam shaping is performed to counteract interference with the receiver. Since the Alamouti code transmitter has two antennas, there is a favourable signal in the direction of the two channels (or in other words, the two direction vectors). The LCMV beam

formation is then investigated. Note that in LCMV beam the aim is to minimize the beam output power  $\min_w w^H R w$ , provided that  $w^H C = b$ . The channel between the first transmitter antenna and the receiver antennas is denoted by  $h_1$  and the channel between the second transmitter antenna and the receiver antennas is denoted by  $h_2$ .

$$\begin{aligned} \mathbf{h}_1 &= [h_{11} \ h_{12} \ \dots \ h_{1N_r}]^T \\ \mathbf{h}_2 &= [h_{21} \ h_{22} \ \dots \ h_{2N_r}]^T \\ \mathbf{C} &= [\mathbf{h}_1 \ \mathbf{h}_2] \\ \mathbf{b} &= [b_1 \ b_2] \end{aligned} \quad (21)$$

According to the structure of Alamouti code, the received signal in the receiver antennas in two consecutive time intervals is as follows:

$$\begin{aligned} \mathbf{r}_1 &= \mathbf{h}_1 s_1 + \mathbf{h}_2 s_2 + \mathbf{n}_1 \\ \mathbf{r}_2 &= -\mathbf{h}_1 s_2^* + \mathbf{h}_2 s_1^* + \mathbf{n}_1 \end{aligned} \quad (22)$$

where  $r_1$  and  $r_2$  are the signal vectors received in the receiver antennas in the first and second time intervals and  $n_1$  and  $n_2$  are the vectors related to the total noise and interference in the receiver antennas in the first and second time intervals. The output of the LCMV beam in the first and second time periods will be  $z_1$  and  $z_2$ .

$$\begin{aligned} z_1 &= \mathbf{w}^H \mathbf{r}_1 = \mathbf{w}^H \mathbf{h}_1 s_1 + \mathbf{w}^H \mathbf{h}_2 s_2 \\ & + \mathbf{w}^H \mathbf{n}_1 \\ & = b_1 s_1 + b_2 s_2 \\ & + \mathbf{w}^H \mathbf{n}_1 \end{aligned} \quad (23)$$

$$\begin{aligned} z_2 &= \mathbf{w}^H \mathbf{r}_2 = -\mathbf{w}^H \mathbf{h}_1 s_2^* \\ & + \mathbf{w}^H \mathbf{h}_2 s_1^* + \mathbf{w}^H \mathbf{n}_2 \\ & = -b_1 s_2^* + b_2 s_1^* \\ & + \mathbf{w}^H \mathbf{n}_2 \end{aligned}$$

To obtain the symbols  $s_1$  and  $s_2$ , first  $\tilde{s}_1$  and  $\tilde{s}_2$  are formed as follows:

$$\begin{aligned}\tilde{s}_1 &= b_1^* z_1 + b_2 z_2^* \\ &= (|b_1|^2 + |b_2|^2) s_1 \\ &\quad + b_1^* \mathbf{w}_1^H \mathbf{n}_1 \\ &\quad + b_2 \mathbf{w}_2^T \mathbf{n}_2^* \\ \tilde{s}_2 &= b_2^* z_1 - b_1 z_2^* \\ &= (|b_1|^2 + |b_2|^2) s_2 \\ &\quad + b_2^* \mathbf{w}_1^H \mathbf{n}_1 \\ &\quad + b_1 \mathbf{w}_2^T \mathbf{n}_2^*\end{aligned}\quad (24)$$

The optimal receiver to decode the symbol  $s_1$  selects point  $a_i$  from all points of the modulation system if and only if:

$$\begin{aligned}d^2((|b_1|^2 + |b_2|^2) a_i, \tilde{s}_1) \\ \leq d^2((|b_1|^2 \\ + |b_2|^2) a_k, \tilde{s}_1) \quad \forall k \neq i\end{aligned}\quad (25)$$

Similarly, to decode the symbol  $s_2$  from all points in the modulation system, the point  $a_i$  is selected if and only if:

$$\begin{aligned}d^2((|b_1|^2 + |b_2|^2) a_i, \tilde{s}_2) \\ \leq d^2((|b_1|^2 \\ + |b_2|^2) a_k, \tilde{s}_2) \quad \forall k \neq i\end{aligned}\quad (26)$$

By considering different  $b$  and LCMV beam conditions, two weight vectors  $w_1$  and  $w_2$  are obtained, and by multiplying the internal vectors of these two vectors in the received signals in the first and second time intervals:

$$\begin{aligned}z_{11} = \mathbf{w}_1^H \mathbf{r}_1 &= \mathbf{w}_1^H \mathbf{h}_1 s_1 + \mathbf{w}_1^H \mathbf{h}_2 s_2 \\ &\quad + \mathbf{w}_1^H \mathbf{n}_1 \\ &= \|\mathbf{h}_1\|^2 s_1 + \mathbf{w}_1^H \mathbf{n}_1\end{aligned}\quad (27)$$

$$\begin{aligned}z_{22} &= (\mathbf{w}_2^H \mathbf{r}_2)^* \\ &= (-\mathbf{w}_2^H \mathbf{h}_1 s_2^* \\ &\quad + \mathbf{w}_2^H \mathbf{h}_2 s_1^* \\ &\quad + \mathbf{w}_2^H \mathbf{n}_2)^* \\ &= \|\mathbf{h}_2\|^2 s_1^* + \mathbf{n}_2^H \mathbf{w}_2 \\ z_{21} = \mathbf{w}_2^H \mathbf{r}_1 &= \mathbf{w}_2^H \mathbf{h}_1 s_1 + \mathbf{w}_2^H \mathbf{h}_2 s_2 \\ &\quad + \mathbf{w}_2^H \mathbf{n}_1 \\ &= \|\mathbf{h}_2\|^2 s_2 + \mathbf{w}_2^H \mathbf{n}_1 \\ z_{12} &= (\mathbf{w}_1^H \mathbf{r}_2)^* \\ &= (-\mathbf{w}_1^H \mathbf{h}_1 s_2^* \\ &\quad + \mathbf{w}_1^H \mathbf{h}_2 s_1^* \\ &\quad + \mathbf{w}_1^H \mathbf{n}_2)^* \\ &= -\|\mathbf{h}_1\|^2 s_2 \\ &\quad + \mathbf{w}_1^T \mathbf{n}_2^*\end{aligned}\quad (28)$$

To obtain the symbols  $s_1$  and  $s_2$ , first  $\tilde{s}_1$  and  $\tilde{s}_2$  are formed as follows:

$$\begin{aligned}\tilde{s}_1 &= z_{11} + z_{22} = (\|\mathbf{h}_1\|^2 \\ &\quad + \|\mathbf{h}_2\|^2) s_1 \\ &\quad + \mathbf{w}_1^H \mathbf{n}_1 + \mathbf{w}_2^T \mathbf{n}_2^* \\ \tilde{s}_2 &= z_{21} - z_{12} \\ &= (\|\mathbf{h}_1\|^2 \\ &\quad + \|\mathbf{h}_2\|^2) s_2 \\ &\quad + \mathbf{w}_2^H \mathbf{n}_1 + \mathbf{w}_1^T \mathbf{n}_2^*\end{aligned}\quad (29)$$

Using  $\tilde{s}_1$  and  $\tilde{s}_2$ , the optimal receiver to decode the symbol  $s_1$  from all points of the modulation system, the point  $a_i$  is selected if and only if:

$$\begin{aligned}d^2((\|\mathbf{h}_1\|^2 + \|\mathbf{h}_2\|^2) a_i, \tilde{s}_1) \leq \\ d^2((\|\mathbf{h}_1\|^2 + \\ \|\mathbf{h}_2\|^2) a_k, \tilde{s}_1) \quad \forall k \neq i,\end{aligned}\quad (30)$$

Similarly, to decode the symbol  $s_2$  from all points in the modulation system, the point  $a_i$  is selected if and only if:

$$d^2((\|\mathbf{h}_1\|^2 + \|\mathbf{h}_2\|^2)a_i, \tilde{s}_2) \leq \quad (31)$$

$$d^2((\|\mathbf{h}_1\|^2 + \|\mathbf{h}_2\|^2)a_k, \tilde{s}_2) \quad \forall k \neq i.$$

#### 4. SIMULATION RESULTS OF THE SECOND PROPOSED METHOD (ADAPTIVE ALGORITHM IN AUXILIARY ANTENNAS)

In the second proposed method, in the case that the transmitter uses Alamouti coding, it will be used to improve the system performance and eliminate interference from the auxiliary antennas based on the distance between the two receiving antennas. In the

following, the figures related to the results and comparisons of this method will be presented.

#### 4.1. Performance Of Different Irradiation Methods for When the Optimum Transmitter Has an Antenna for The Channel With Rail Feeder

In this section, the performance of the method presented in the dissertation for the paper with co-channel interference in the channel with Riley feeder will be examined.

The interference channel is unknown, 1 Tx antenna, 4 Rx antennas,  
SIR = 0 dB

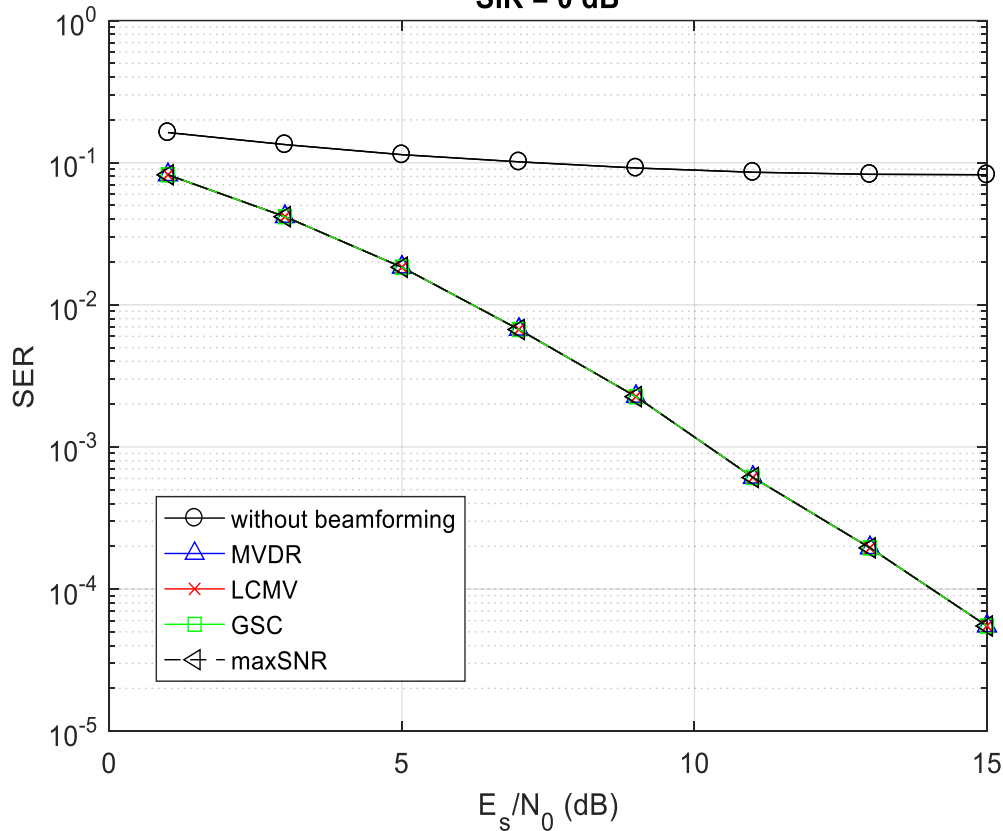

**Fig.3. Comparison of the performance of different irradiation methods in eliminating interference when the receiver does not interfere with information from the channel. The characteristics of the simulation are as follows: QPSK modulation, SIR = 0 dB, an optimal single-antenna transmitter, a single-antenna interferometer, a 4-antenna receiver.**

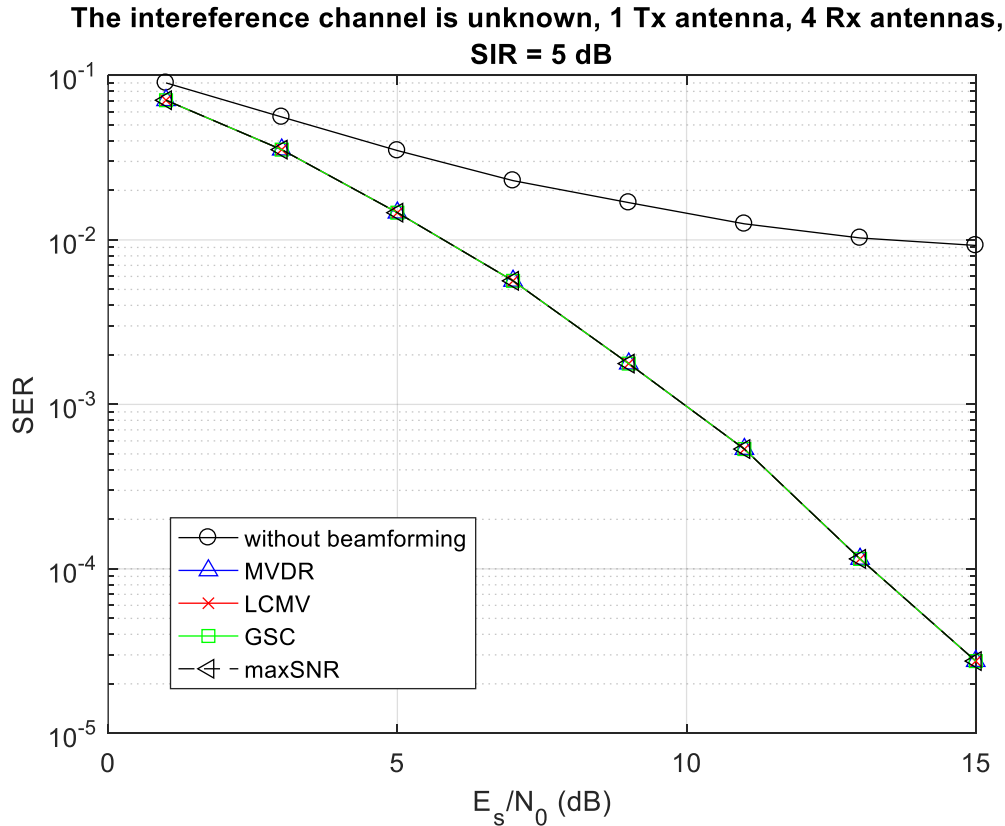

**Fig.4. Comparison of the performance of different irradiation methods in eliminating interference when the receiver does not interfere with information from the channel.**

#### 4.1.1. Without Knowing the Interference Channel

MVDR and Maximum SNR methods do not need to know the interference channel. The LCMV and GSC methods can be used both with and without the knowledge of the interference channel; If the interference channel is not known, the conditions of the optimization problem will be set only on the basis of the beam output of one in the desired signal direction. If there is also information about the channel (direction) of interference, the condition of zero (null) output of the radiator in the direction of interference can be added to the conditions of the optimizer problem.

If the receiver does not know the interference channel and the desired transmitter has only one antenna, the optimization problem will be the same in all three methods MVDR, LCMV and GSC, and these three methods will work the same. Simulation also confirms this. (1) In general, the LCMV and GSC methods are equivalent to each other [23]. If only one condition is met for LCMV or GSC radiation, this radiation will be the same as MVDR radiation.

Fig.3 and Fig.4 show the performance of these three radiators for  $SIR = 0$  &  $5$  dB, when there is an interfering device and 4 receiver antennas.

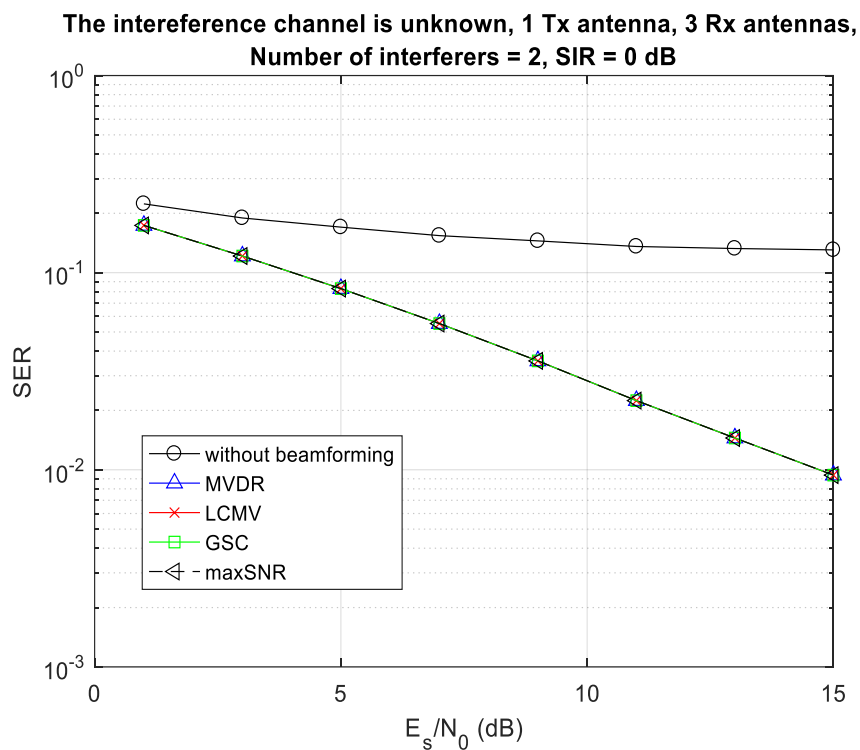

Fig.5. Effect of increasing the number of interferers.

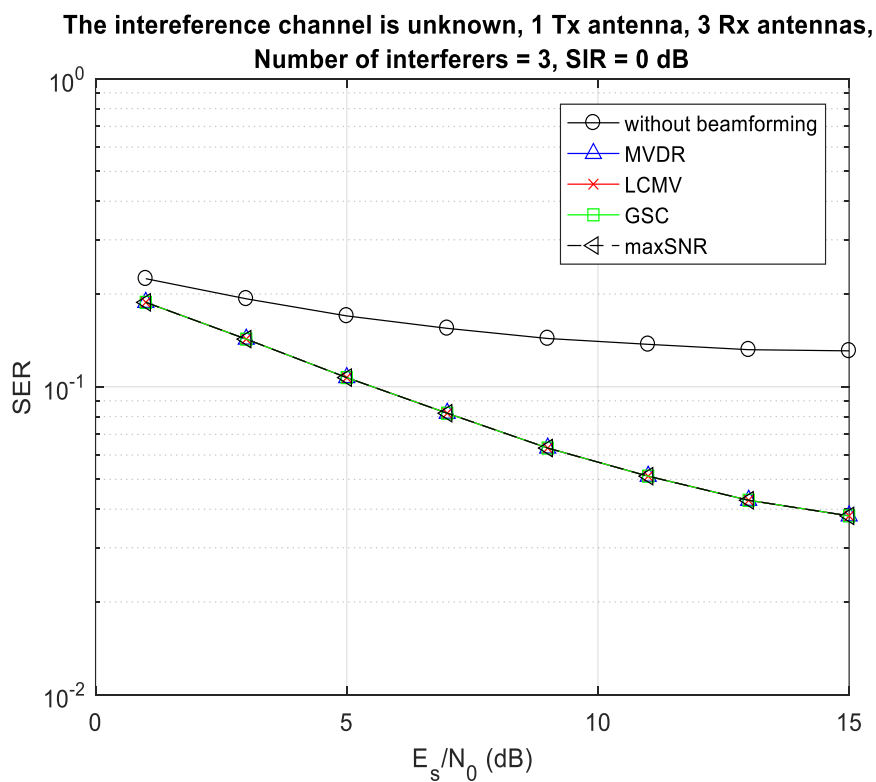
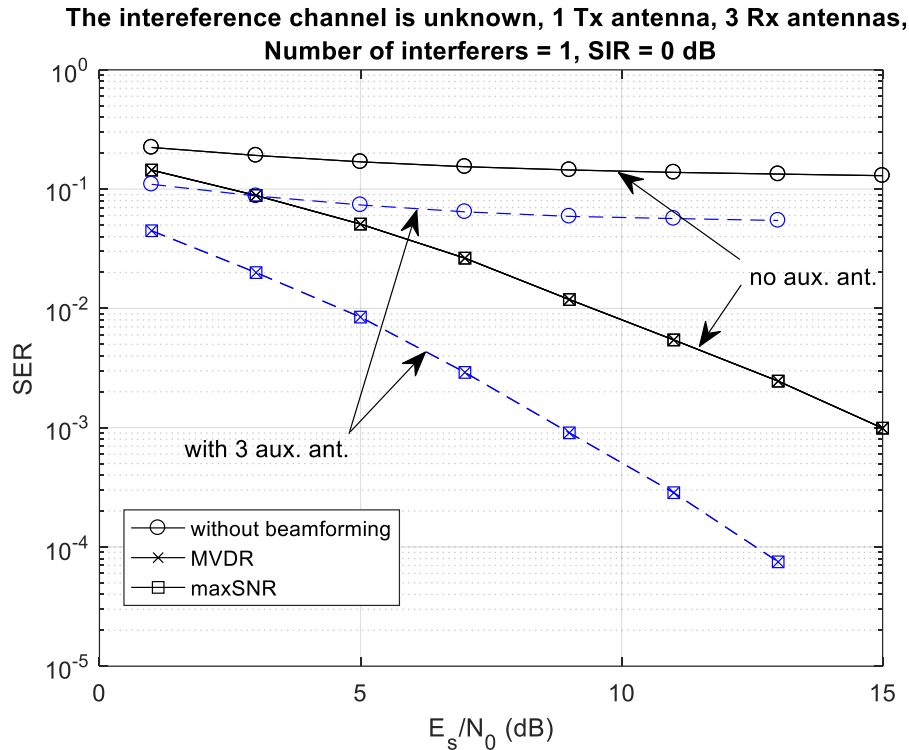

Fig.6. Effect of increasing the number of interferers.



**Fig.7. The effect of the presence and absence of an auxiliary antenna in eliminating interference. The characteristics of the simulation are as follows: QPSK modulation, a desirable single-antenna transmitter, a single-antenna interferometer, a receiver with 3 main antennas, SIR = 0 dB.**

MVDR, LCMV and GSC are equivalent when the transmitter is single antenna and the receiver is not aware of the interference channel. Also, the performance of the maxSNR beam is exactly the same as the other three beams.

The characteristics of the simulation are as follows: QPSK modulation, SIR = 5 dB, a desirable single-antenna transmitter, a single-antenna interferometer, a 4-antenna receiver. MVDR, LCMV and GSC are equivalent when the transmitter is single antenna and the receiver is not aware of the interference channel. Also, the performance of the maxSNR beam is exactly the same as the other three beams.

The effect of increasing the number of interferers is shown in Fig.5 and Fig.6.

Fig.7 and Fig.8 show the performance of interference methods without knowing the interference channel, and for the case where the optimum transmitter has an antenna in the presence or absence of an auxiliary antenna. The receiver has 3 main antennas whose spatial distance is such that the channel between the transmitter antenna and the main antennas of the receiver are independent. An auxiliary antenna is provided next to each main antenna. The distance between the auxiliary antenna and the main antenna is small so that its gain channel is equal to the gain of the main antenna and only its phase is different from the main channel phase. Thus, the placement of auxiliary antennas does not require enlarging the physical dimensions of the array. Also, as shown in the figure below, because the auxiliary antenna is close to the

main antenna and its channel is not independent of the main antenna channel, adding diverse auxiliary antennas available in the system does not increase. But as can be seen from Fig.7 and Fig.8, adding an auxiliary antenna helps a lot to eliminate interference Fig.7. Operation of different methods without knowing the interference channel, in the presence of a desirable single-antenna transmitter and a single-antenna interfering and a receiver with 3 main antennas, once without auxiliary antenna (solid and black lines) and once with 1 antenna Auxiliary next to each main antenna,

i.e. a total of 3 auxiliary antennas (blue dashed line) shows.

Fig.8 also shows the effect of auxiliary antennas in eliminating interference. In this scenario, there is a desirable single-antenna transmitter, three single-antenna interferers, and a receiver with two main antennas. Operation of different methods without auxiliary antenna (continuous black lines), when there is one auxiliary antenna next to each main antenna (blue stripes) and when there are 2 auxiliary antennas next to each main antenna (red dotted line point) has been shown.

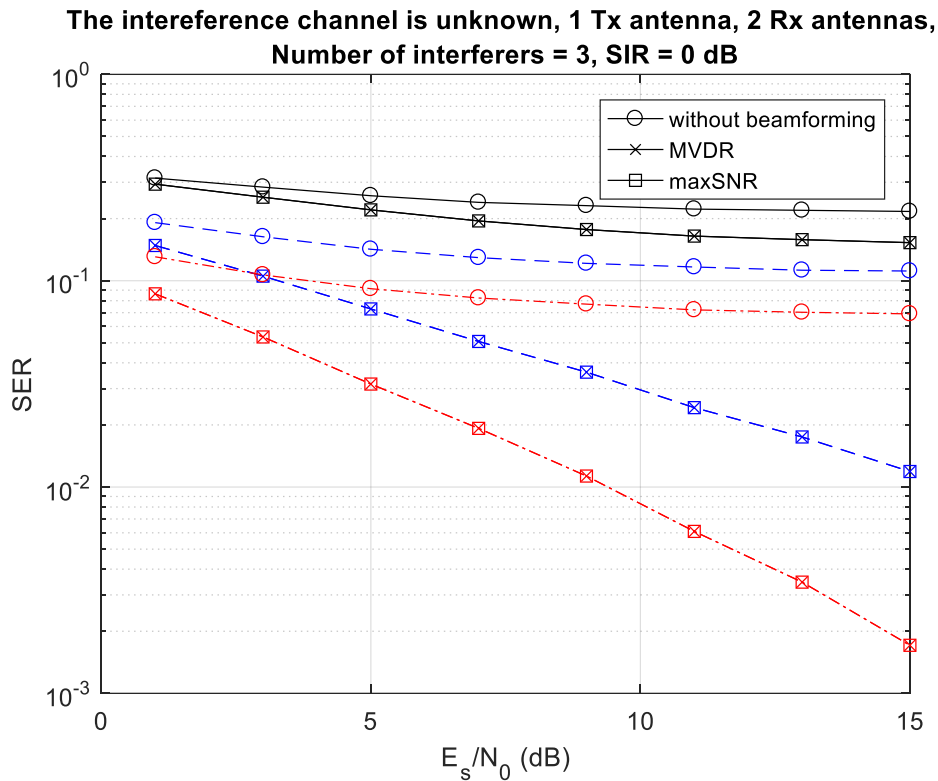

**Fig.8. The effect of the presence and absence of an auxiliary antenna in eliminating interference. Performance without auxiliary antenna (continuous black lines), when there is one auxiliary antenna next to each main antenna (blue stripes) and when there are 2 auxiliary antennas next to each main antenna (red dotted line point). The specifications of the simulation are as follows: QPSK modulation, a desirable single-antenna transmitter, a single-antenna interferometer, a receiver with 2 main antennas, SIR = 0 dB.**



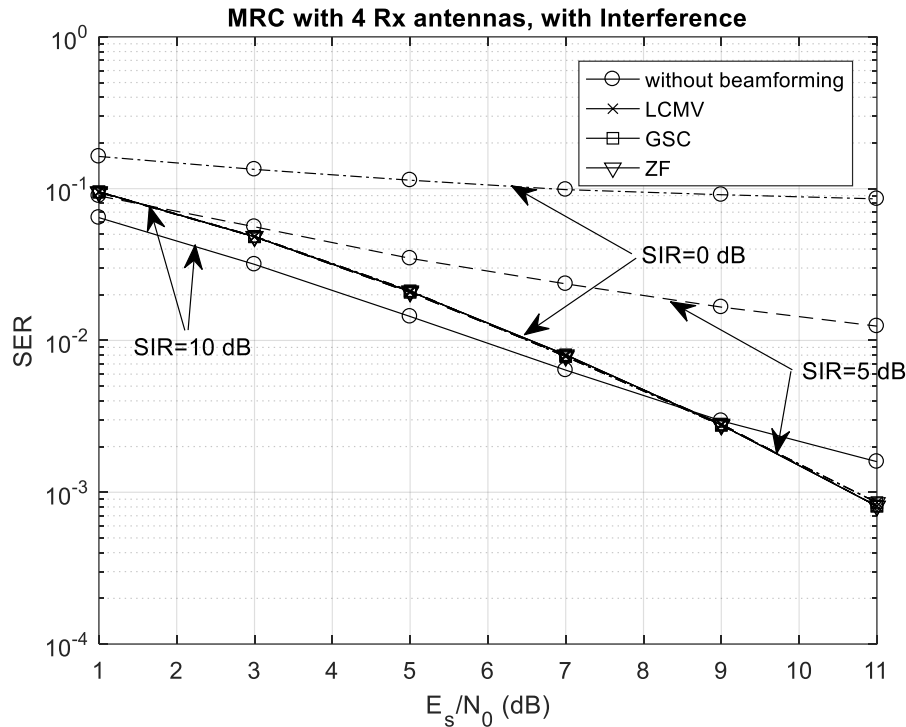

**Fig.9. Comparison of the performance of different irradiation methods in eliminating interference when the receiver is aware of the interference; For different SIRs. The specifications of the simulation are as follows: QPSK modulation, a desirable single-antenna transmitter, a single-antenna interferometer, a receiver with 4 main antennas.**

#### 4.1.2. With Information from the Interference Channel

This section examines the methods that work by knowing the interference channel. These methods include LCMV, GSC, and ZF. In all three methods, the radiator sets the interference direction to zero in order to completely eliminate the interference. Although the mathematical relationships for obtaining weights are different in these three methods, in all three methods the radiation output is in the direction of zero interference. As can be seen from the simulation results, the performance of these three methods is the same in terms of symbol error rate.

Fig.9 shows the performance of these three methods for different SIRs. An

important and interesting point about radiators that work with the knowledge of the interference direction and set it to zero in this direction is that when the interference power is low (SIR is high), placing zero in the direction of interference causes one of the degrees of liberty of the recipient is merely to satisfy this condition; And reduces the ability of the radiator to reduce noise and interfere with its output. As a result, when the noise power is high (SNR is low) and the interference power is low (SIR is high), spending one degree of receiver freedom to set zero in the direction of interference causes the system to operate at a degree that the freedom of the system is simple to put zero in the non-interfering direction, to get worse.

For example, at 0 for weak interference (SIR = 10 dB) and at low SNRs, receiver performance without beam shaping is better than radionuclide methods.

The performance of the LCMV, GSC, and ZF methods when an auxiliary antenna is located next to each main antenna is shown in Fig.10.

The effect of auxiliary antennas to deal with interference in the presence of multiple interference is shown in Fig.11 and Fig.12.

Fig.11 shows two interferometers and 3 main receiver antennas. The solid black lines show the performance without a small antenna and the blue dashed lines show the performance with an auxiliary antenna next to each main antenna.

The solid black lines show the performance without a small antenna and the blue dashed lines show the performance with an auxiliary antenna next to each main antenna.

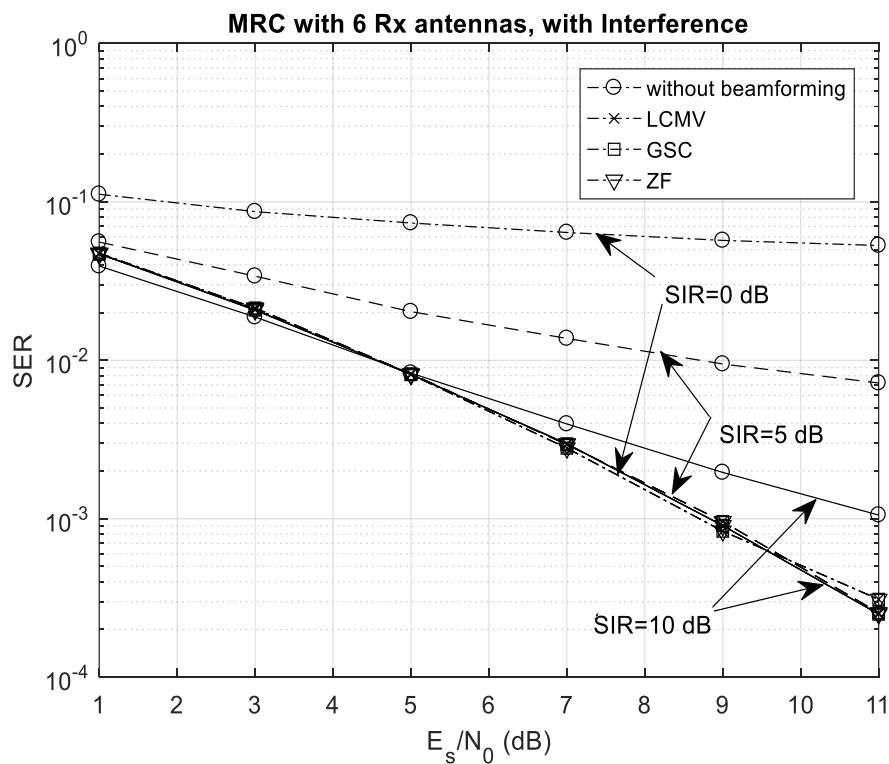

**Fig.10. Comparing the performance of different irradiation methods in eliminating interference when the receiver is aware of the interference; For different SIRs. The specifications of the simulation are as follows: QPSK modulation, a desirable single-antenna transmitter, a single-antenna interferometer, a receiver with 3 main antennas and 3 auxiliary antennas.**

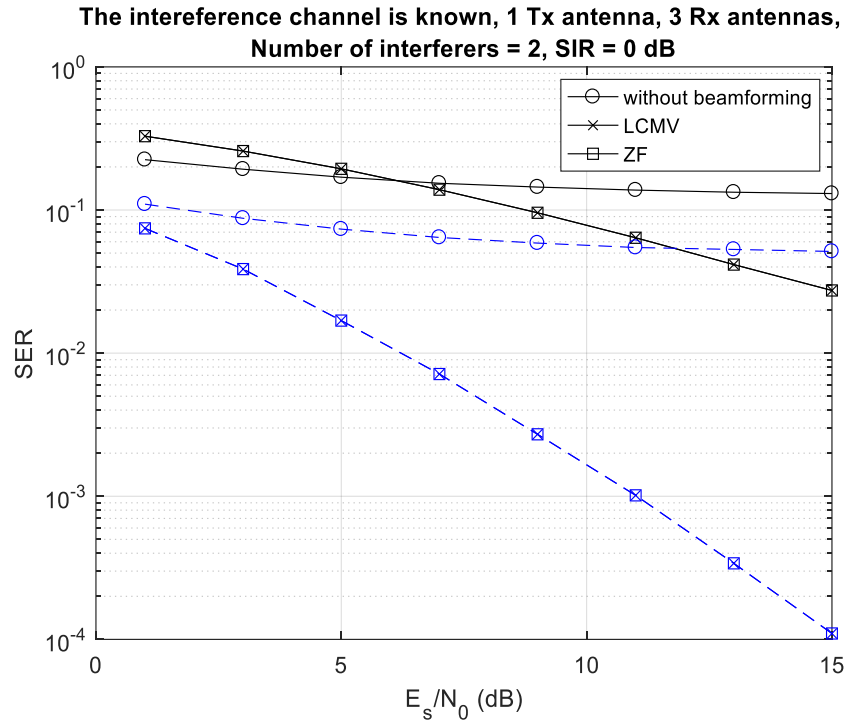

**Fig.11. Effect of presence and absence of auxiliary antenna in eliminating interference. The characteristics of the simulation are as follows: QPSK modulation, one optimal single antenna transmitter, 2 single antenna interferers, receiver with 3 main antennas, SIR = 0 dB.**

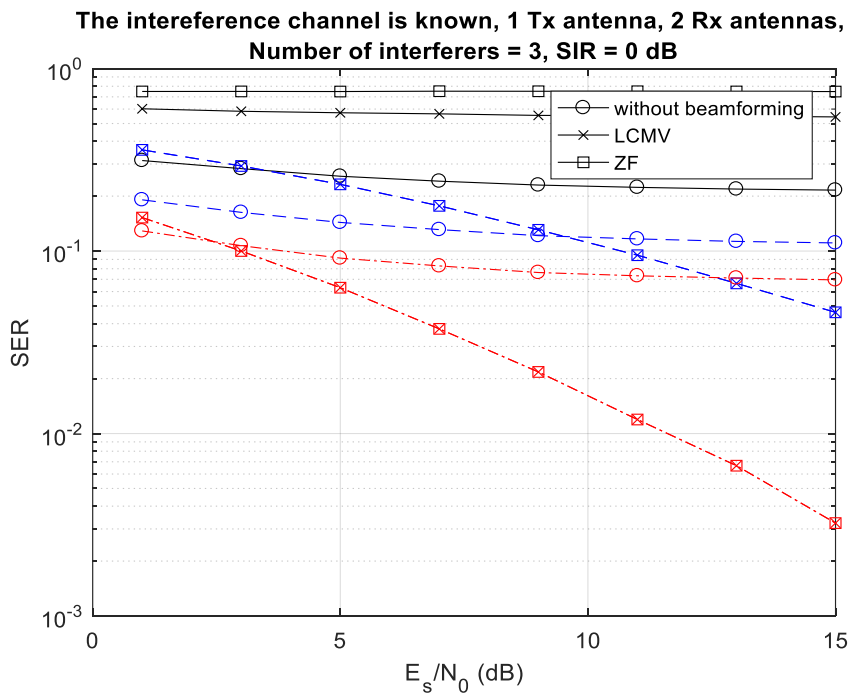

**Fig.12. The effect of the presence and absence of auxiliary antenna in eliminating interference. The specifications of the simulation are as follows: QPSK modulation, a desirable single-antenna transmitter, 3 single-antenna interferers, a receiver with 2 main antennas, SIR = 0 dB.**

Fig.12 shows three interferometers and two main receiver antennas. The solid black lines show the performance without a small antenna, the blue dashed line shows the performance with one auxiliary antenna next to each main antenna, and the red dotted lines show the performance with two auxiliary antennas next to each main antenna. In the case without auxiliary antennas, since the sum of the receiving antennas is less than the interfering antennas, the ZF method fails completely. Despite the auxiliary antenna, the performance of the ZF and LCMV methods is exactly the same.

The solid black lines show the performance without a small antenna, the blue dashed line shows the performance with one auxiliary antenna next to each main antenna, and the red dotted lines show the performance with two auxiliary antennas next to each main antenna.

## 4.2. Performance of Different Irradiation Methods

Operation of different irradiation methods for when the desired transmitter has more than one antenna.

When the transmitter has multiple antennas, the Alamouti code is one of the most important and widely used space-time codes. Assuming that the desired transmitter uses the Alamouti code and in the presence of interference, this section examines the methods of beam formation in the receiver with and without the help of auxiliary antennas in the receiver.

### 4.2.1. Recommended LCMV Beam

## Performance in Alamouti Code Receiver

Fig.13 shows the simulation results for the case where the MIMO transmitter uses the Alamouti code, and in the presence of interference, when the vector  $b$  is  $b = [1 \ 1]$ ,  $b = [\|h_1\| \ \|h_2\|]$  and  $b = [\|h_1\|^2 \ \|h_2\|^2]$ . Among these three vectors of  $b$ , the state  $b = [\|h_1\|^2 \ \|h_2\|^2]$  has a better performance in terms of the probability of a symbol error.

In addition, another case is considered. In order to decode the symbols of Alamouti code, the signal of each transmitting antenna for the other antenna is considered as interference and the LCMV irradiation conditions are set as two vectors  $b = [0 \ \|h_2\|^2]$  and  $b = [\|h_1\|^2 \ 0]$ ; And from them two vectors of weight  $w_1$  and  $w_2$  are obtained.

When the optimum signal power and the interference power are equal ( $SIR = 0 \text{ dB}$ ), the simulation results are shown in Fig.13. Therefore, when using the LCMV beam, it is best to obtain two different weight vectors corresponding to the two Alamouti transmitter antennas. In this case, each time the output of the radiator in the direction of one of the transmitter antennas is equal to  $\|h\|^2$  and in the direction of the other antenna is zero. In the following, wherever the LCMV beam is mentioned for the MIMO channel, the beam with these conditions is considered.

In both forms, the performance of the radiator is shown for different conditions. The specifications of the simulation are as follows: QPSK modulation, a desirable dual-antenna transmitter, a single-antenna interferometer, a receiver with 4 main antennas. In Fig.14, the receiver is not aware of the interference.

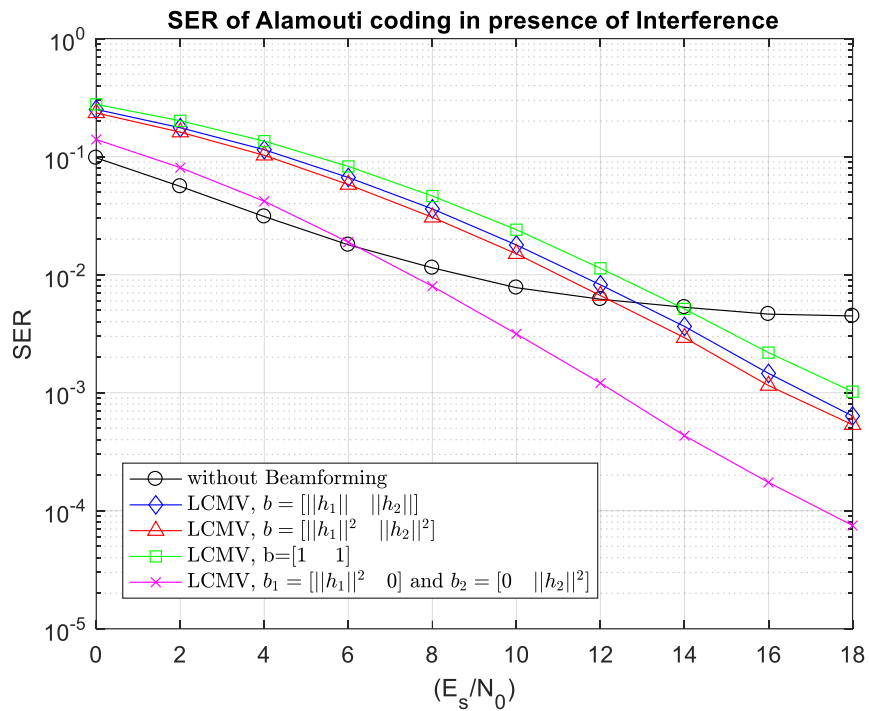

Fig.13. LCMV radiation performance in interference elimination when the transmitter uses the Alamouti code and the receiver is unaware of the interference (SIR = 5dB).

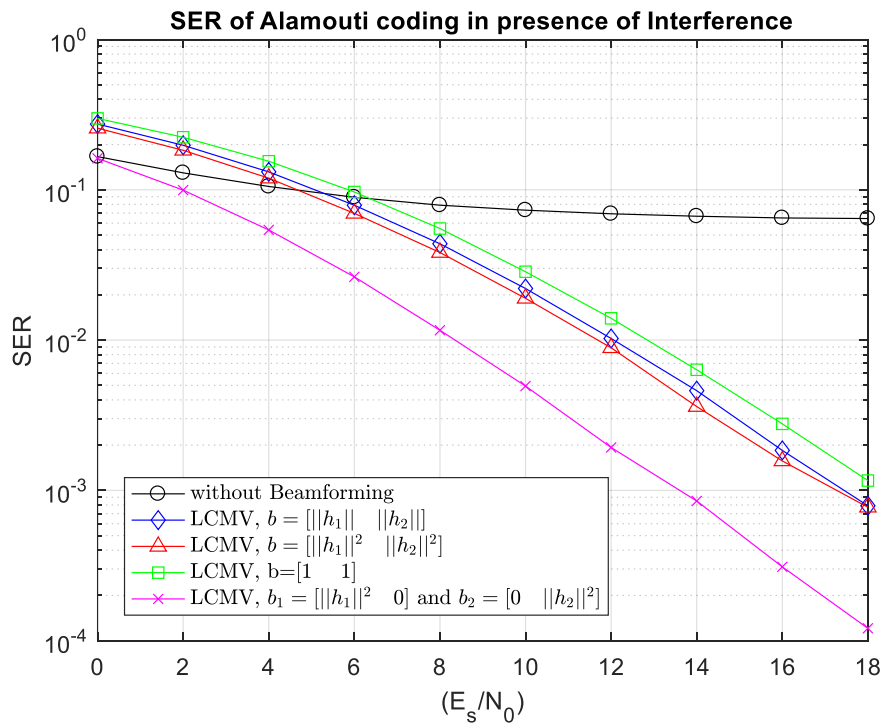

Fig.14. LCMV beam performance in eliminating interference when the transmitter uses Alamouti code (SIR = 0dB).

#### 4.2.2. Performance of the Proposed MVDR Beam in the Alamouti Code Receiver

As seen in the previous section, when the transmitter has a single antenna and the receiver has multiple antennas, the MVDR beam performs well in eliminating interference. The performance of this irradiator is then evaluated when the transmitter uses the Alamouti code. To use the MVDR beam for the MIMO communication channel, the weight vector is obtained by the number of  $N_t$  desired transmitter antennas. In fact,  $N_t$  is a weight vector, each of which is in the direction of one of the desired transmitter antennas, and the signal of the other transmitter antennas,

along with interference and noise, is considered an undesirable signal. Fig.15 and Fig.16 show the performance of the MVDR irradiator against interference at SIR values of 0 and 5 dB. The simulation specifications for both forms are as follows: QPSK modulation, a desirable dual-antenna transmitter, a single-antenna interferometer, and a receiver with 4 main antennas.

#### 4.2.3 Recommended maxSNR Beam Performance in Alamouti Code Receiver

Fig.17 and Fig.18 show the maxSNR irradiator performance for different SIRs. Symbols detected by the maxSNR beam are calculated using the following criterion when the transmitter uses the Alamouti code.

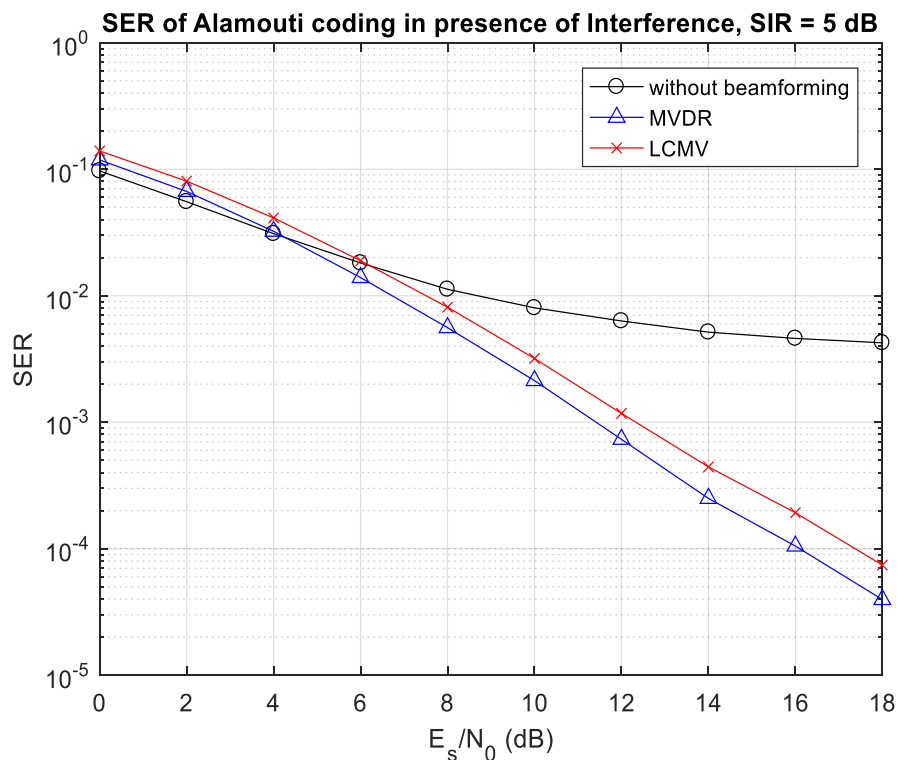

**Fig.15.** The function of the MVDR beam is to eliminate interference when the transmitter uses Alamouti code.

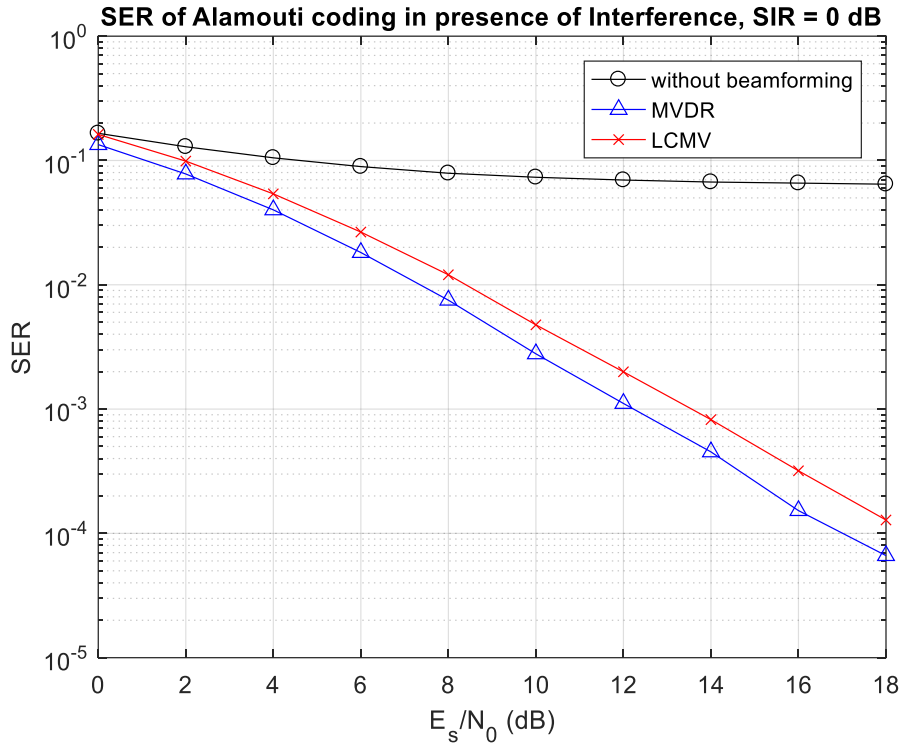

*Fig.16. Performance of the MVDR beam in eliminating interference when the transmitter uses the Alamouti code.*

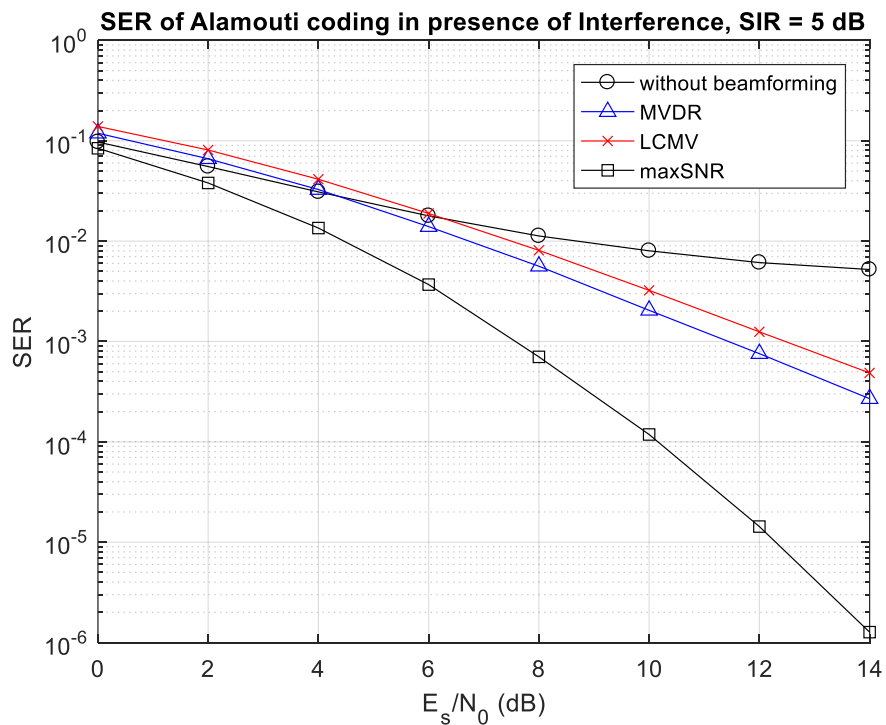

*Fig.17. Comparison of the performance of different irradiation methods to deal with interference when the transmitter uses the Alamouti code.*

$$\hat{\mathbf{x}}_1 = \arg \min_{\mathbf{c}_t} \sum_{t=0,1} |\Theta^H(\mathbf{C}_1) \mathbf{y}_t - \Theta^H(\mathbf{C}_1) \Omega(\mathbf{C}_1) \mathbf{c}_t|^2 \quad (32)$$

In the above relation, among all the vector symbols sent by  $\mathbf{c}_t$  with dimensions  $2 \times 1$ , a vector is found that minimizes the above expression. If the modulation order used in the transmitter is  $M$ , the number of possible vectors for the symbols sent from the transmitter antennas  $\mathbf{c}_t$  is equal to  $M^{N_t} = M^2$ . Therefore, the computational complexity of the maxSNR method is proportional to  $M^2$ . Since the sender uses the alumni code, when finding the minimum value, if the symbol sent at time  $t = 0$  is considered equal to  $\mathbf{c}_0 = [s_1, s_2]^T$ , the symbol sent at time

$t = 1$  must be considered  $\mathbf{c}_1 = [-s_2^*, s_1^*]^T$ .

The specifications of the simulation are as follows: SIR = 5 dB, QPSK modulation, a desirable two-antenna transmitter, a single-antenna interferometer, a receiver with 4 main antennas.

Fig.19 shows the performance of different irradiation methods when two sources of interference are present in the medium. In this scenario, the MVDR beam is better than the LCMV, and the maxSNR beam is better than both. The specifications of the simulation are as follows:

SIR = 0.5 dB, QPSK modulation, an optimal dual antenna transmitter, two single-antenna interceptors, the receiver has 4 main antennas.

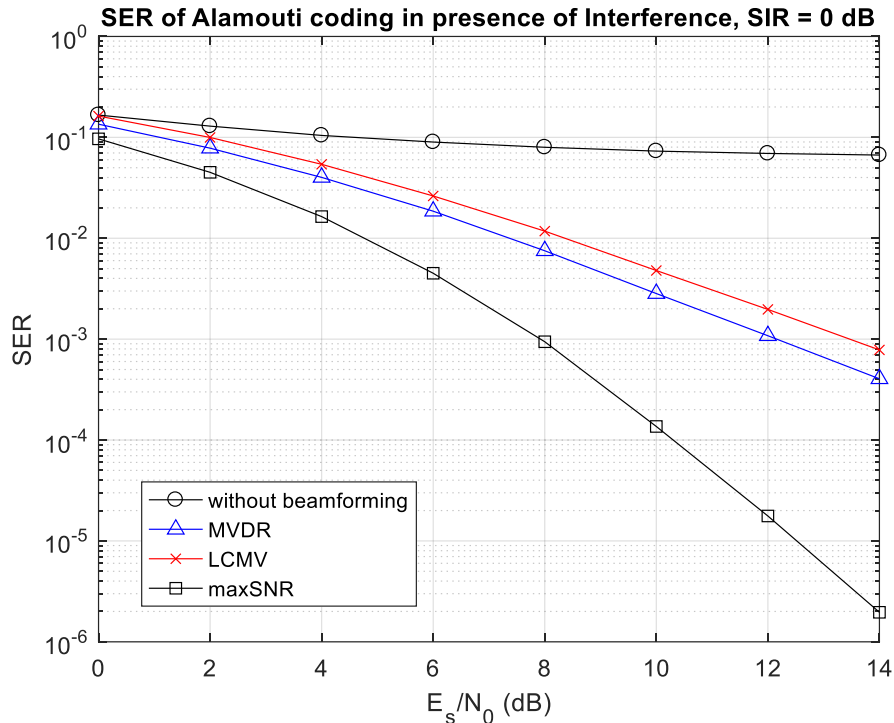

**Fig.18. Comparison of the performance of different irradiation methods to deal with interference when the transmitter uses the Alamouti code.**



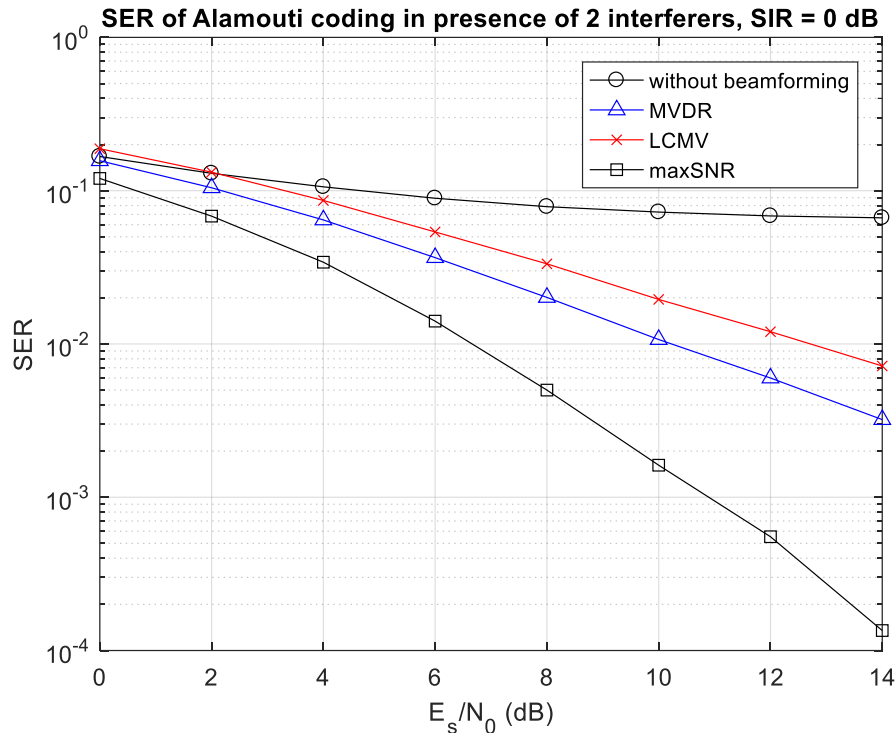

**Fig.19. Comparison of the performance of different irradiation methods to deal with interference when two sources of interference are in the environment and the transmitter uses the Alamouti code.**

Fig.20 shows the operation of different irradiation methods when the transmitter uses the Alamouti code, there are two sources of interference in the environment and the receiver has three main antennas. Therefore, in this scenario, the number of receiving antennas is less than the sum of the desired transmitter antennas and interference. As can be seen from the diagram, in this case the performance of the irradiation methods against interference is severely impaired.

The specifications of the simulation are as follows: SIR = 0 dB, QPSK modulation, a desirable two-antenna transmitter, two single-antenna interceptors, the receiver has 3 main antennas. Therefore, the number of receiver antennas is less than the sum of the desired transmitter antennas and interferers.

As a result, the performance of irradiation methods has been severely impaired.

Now, if an auxiliary antenna is used next to each main antenna, as shown in Fig.21, the performance of the system will be greatly improved. The use of auxiliary antennas can not be the two main advantages of channels because their distance from the main antennas is less than 10 times the wavelength and the channel between the transmitter antenna and the auxiliary antenna is highly correlated with the channel between the transmitter antenna and the main antenna. MIMO means providing spatial diversity and increasing bit rate; But irradiation by using auxiliary antennas and counteracting the interference with their help, greatly improves the performance of the system. Especially

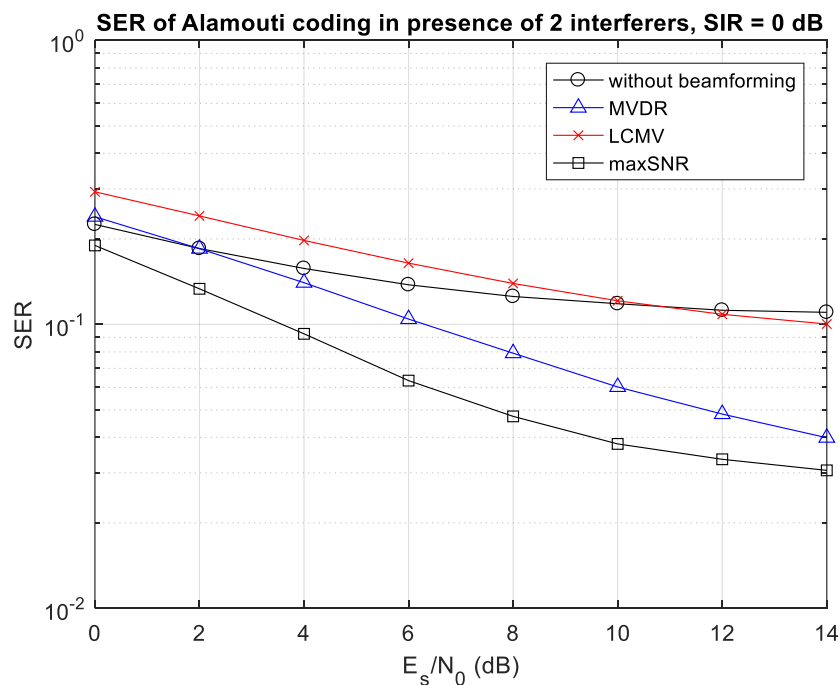

**Fig.20. Comparison of the performance of different irradiation methods to deal with interference when two sources of interference are in the environment and the transmitter uses the Alamouti code.**

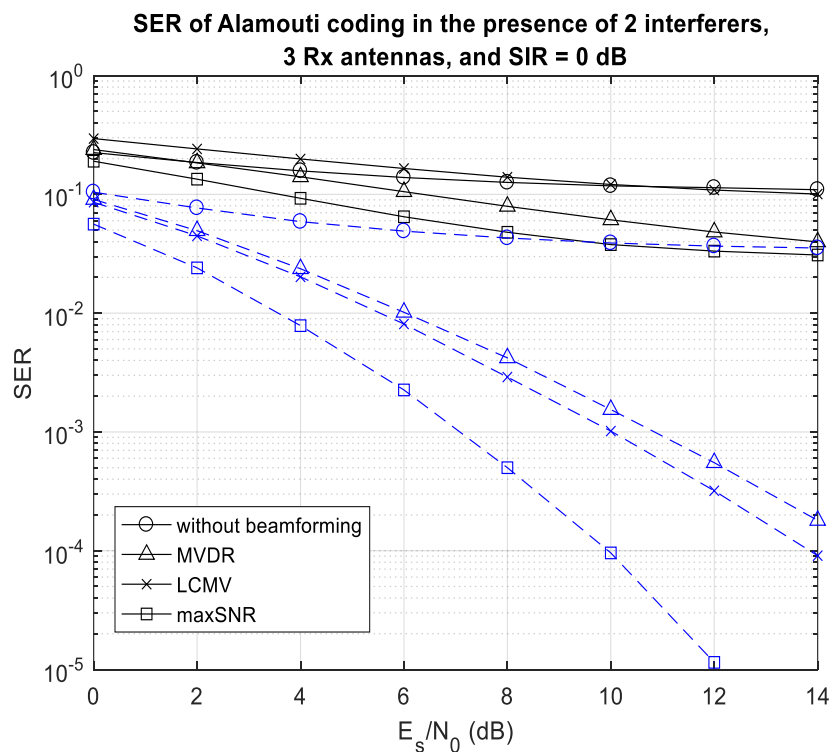

**Fig.21. The effect of auxiliary antenna on the performance of different irradiation methods in eliminating interference. The continuous black lines correspond to the state without the auxiliary antenna and the blue dashed lines correspond to the state with the auxiliary antenna.**

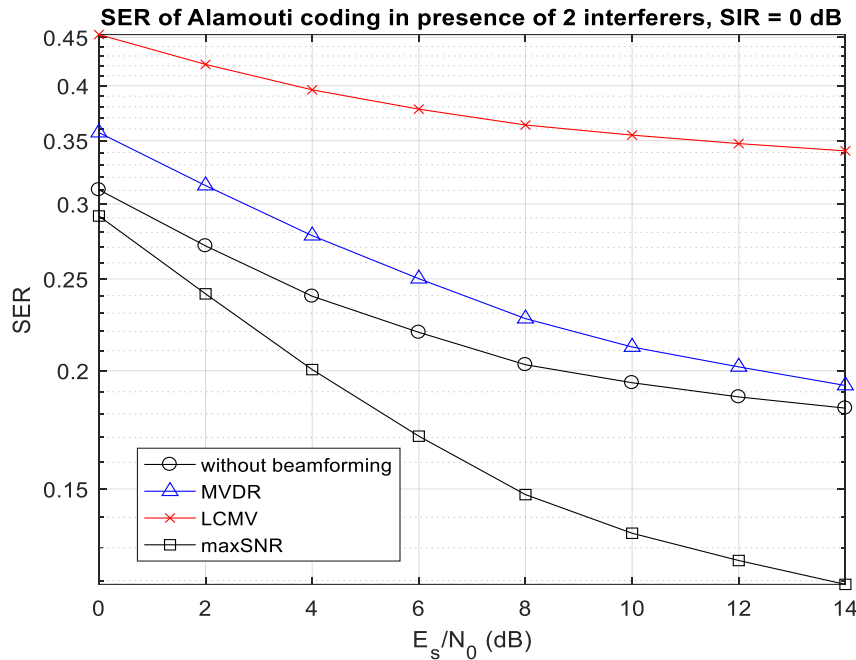

**Fig.22. Comparison of the performance of different irradiation methods to deal with interference when two sources of interference are in the environment and the transmitter uses the Alamouti code.**

when the number of receiver antennas is less than the total number of transmitter antennas (including both optimal transmitter and interference), the use of auxiliary antenna in the receiver at low cost (both in terms of space required for the antenna, etc.) will significantly increase system performance.

The specifications of the simulation are as follows:  $SIR = 0$  dB, QPSK modulation, a desirable dual antenna transmitter, two single-antenna interceptors, the receiver has 3 main antennas, which also has 1 auxiliary antenna next to each main antenna.

In Fig.22, the simulation specifications are as follows:  $SIR = 0$  dB, QPSK modulation, a desirable dual antenna transmitter, two single-antenna interceptors, the receiver has 2 main antennas. Therefore, the number of receiver antennas is less than the sum of the desired transmitter antennas and interferers. As a result, the performance

of irradiation methods has been severely impaired.

In Fig.23, the simulation specifications are as follows:  $SIR = 0$  dB, QPSK modulation, a desirable dual-antenna transmitter, two single-antenna interceptors, the receiver has 2 main antennas, and 1 auxiliary antenna is located next to each main antenna. Comparison shows that the use of auxiliary antennas greatly improves the performance of irradiation methods.

In Fig.24, the simulation specifications are as follows:  $SIR = 0$  dB, QPSK modulation, a desirable two-antenna transmitter, two single-antenna interceptors, the receiver has 2 main antennas, and next to each main antenna there are 2 auxiliary antennas. Comparison shows that the use of auxiliary antennas greatly improves the performance of irradiation methods.

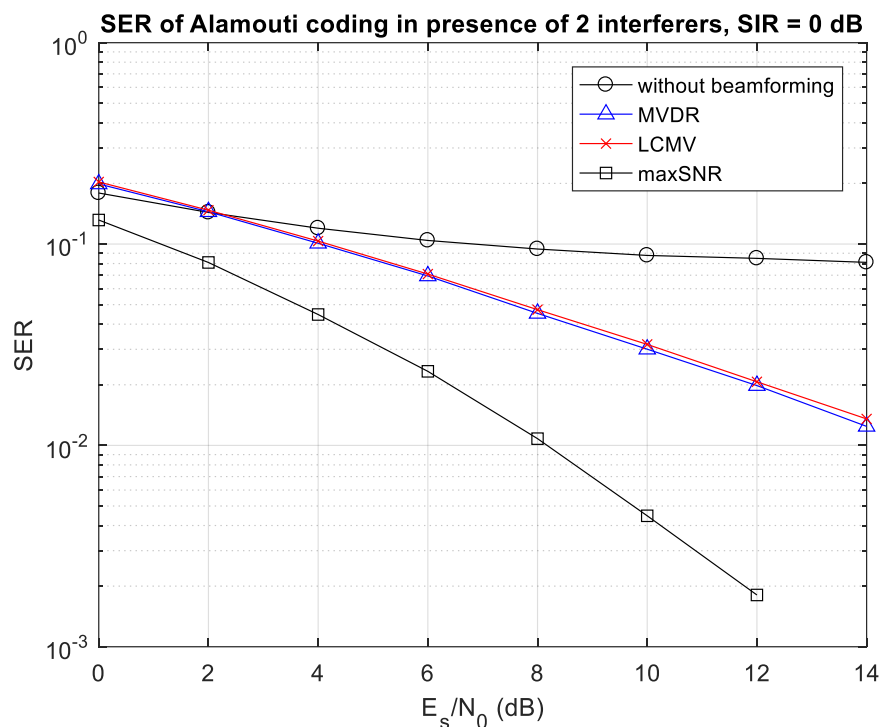

**Fig.23. Comparison of the performance of different irradiation methods to deal with interference when two sources of interference are in the environment and the transmitter uses the Alamouti code.**

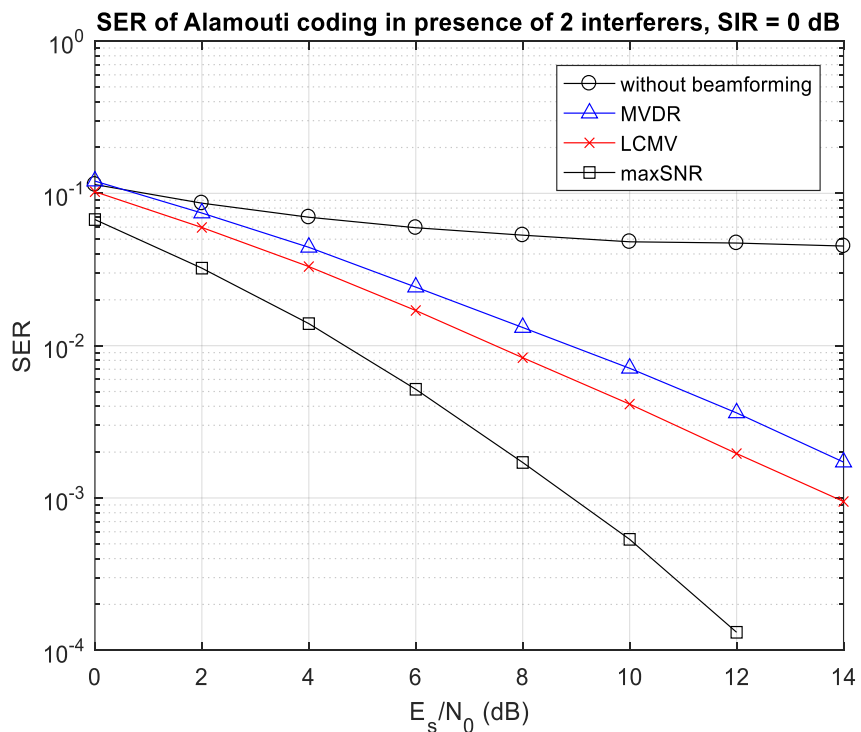

**Fig.24. Comparison of the performance of different irradiation methods to deal with interference when two sources of interference are in the environment and the transmitter uses the Alamouti code.**

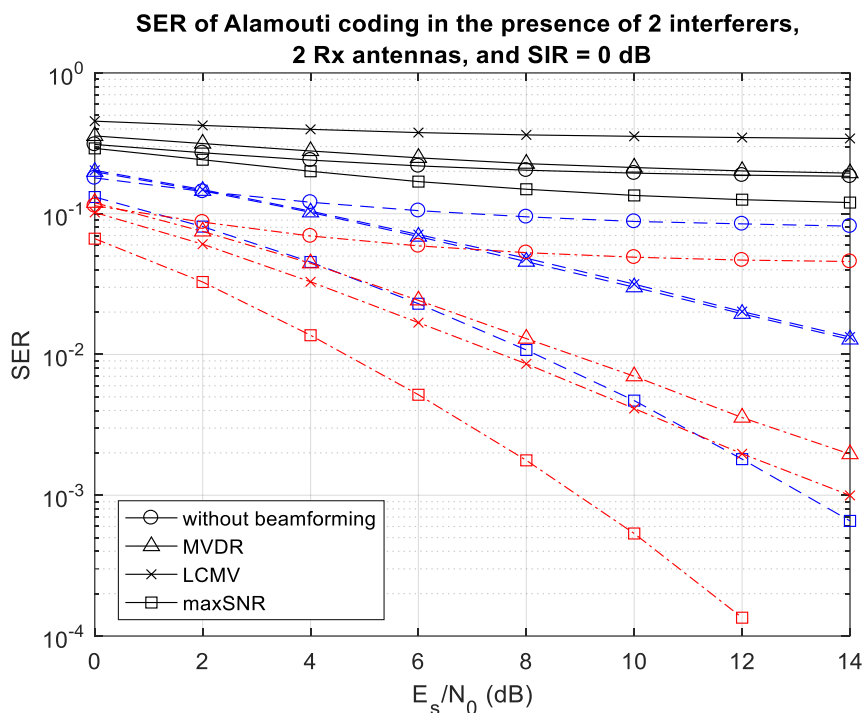

**Fig.25. The effect of auxiliary antenna on the performance of different irradiation methods in eliminating interference.**

For easier comparison and to investigate the effect of auxiliary antennas in the elimination of interference by different radiators, the diagrams in Fig.21, Fig.22 and Fig.23 are shown together in Fig.24, where the continuous black lines correspond to the state without the auxiliary antenna. It is the case that there is 1 auxiliary antenna next to each main antenna and the red dotted line point is related to the case where there are 2 auxiliary antennas next to each main antenna. Fig.25 shows the effect of auxiliary antenna on the performance of different irradiation methods in eliminating interference.

The continuous black lines correspond to the state without auxiliary antenna, the blue dashed line corresponds to the state with 1 auxiliary antenna next to each main antenna, and the red dotted line corresponds to the

state with 2 auxiliary antennas next to each main antenna.

## 5. CONCLUSION

The use of an adaptive algorithm to assist the received signal beam will eliminate interference and improve the performance of MIMO wireless systems. Adding an auxiliary antenna significantly improves system performance. Especially before adding the auxiliary antenna, the number of main antennas of the receiver is less than the total number of transmitter antennas and by adding the auxiliary antennas, the total number of receiver antennas exceeds the total number of transmitter antennas. In this case, adding an auxiliary antenna will improve the performance of the system as a whole and to a great extent. The reason for this position is

that in order to eliminate interference using irradiation methods, it is necessary that the number of receiving antennas is greater than the number of transmitting antennas.

It was also shown that the adaptive algorithm can be adapted to different channels and with different modulations. In both internal and external scenarios, the algorithm will perform well despite the increase in path loss.

In any case, in order to be able to use the MIMO system to increase the transmission rate through space multiplexing or reduce the error rate through space diversification, adjacent antennas must be spaced far enough apart that all paths between the different antennas between the transmitter and receiver are independent of each other. But auxiliary antennas do not have this feature and do not help to increase the transmission rate or reduce the error rate. But as shown in this paper, auxiliary antennas through radiation are very suitable for eliminating interference.

## REFERENCES

- [1] Z. Zhao et al., "On the Design of Computation Offloading in Fog Radio Access Networks," in *IEEE Transactions on Vehicular Technology*, vol. 68, no. 7, pp. 7136-7149, July 2019
- [2] S. Wang and M. Wang and B. Jia and Y. Li, "Capacity of two-way in-band full-duplex relaying with imperfect channel state information," *IEICE Transactions on Communications*, vol. 101, no. 4, pp. 1108-1115, 2018
- [3] S. Wang, D. Wang, C. Li and W. Xu, "Full Duplex AF and DF Relaying Under Channel Estimation Errors for V2V Communications," in *IEEE Access*, vol. 6, pp. 65321-65332, 2018
- [4] Z. Zhao, M. Xu, Y. Li and M. Peng, "A Non-Orthogonal Multiple Access-Based Multicast Scheme in Wireless Content Caching Networks," in *IEEE Journal on Selected Areas in Communications*, vol. 35, no. 12, pp. 2723-2735, Dec. 2017
- [5] C. Li and S. Wang, "An improved Adaptive Beamforming Algorithm for 5G Interference-coexistence communication," 2019 *IEEE/CIC International Conference on Communications Workshops in China (ICCC Workshops)*, 2019
- [6] Badoi, CI., Prasad, N., Croitoru, V. et al. 5G Based on Cognitive Radio. *Wireless Pers Commun* 57, 441-464 (2011)
- [7] V. R. Cadambe and S. A. Jafar, "Interference Alignment and Degrees of Freedom of the MIMO-User Interference Channel," in *IEEE Transactions on Information Theory*, vol. 54, no. 8, pp. 3425-3441, Aug. 2008
- [8] Lu Yang, Wei Zhang, "Interference Coordination for 5G Cellular Networks," Springer, 2015.
- [9] Available: <https://www.verizon.com/>.
- [10] Ali, E., Ismail, M., Nordin, R. et al. Beamforming techniques for massive MIMO systems in 5G: overview, classification, and trends for future research. *Frontiers Inf Technol Electronic Eng* 18, 753-772 (2017)
- [11] Fan Zhu, Kyung Sik Ryu and Myoung Seob Lim, "Combined beamforming with space-time block coding using double antenna array group," *Eighth*

- IEEE International Symposium on Spread Spectrum Techniques and Applications - Programme and Book of Abstracts (IEEE Cat. No.04TH8738), 2004
- [12] K. Huang, H. Wang, J. Hou and S. Jin, "Joint Spatial Division and Diversity for Massive MIMO Systems," in *IEEE Transactions on Communications*, vol. 67, no. 1, pp. 258-272, Jan. 2019
- [13] Yang, Yu-Han, Shih-Chun Lin, and Hsuan-Jung Su. "Multiuser MIMO downlink beamforming design based on group maximum SINR filtering." *IEEE Transactions on Signal Processing* 59.4 (2011)
- [14] Hsuan-Jung Su and E. Geraniotis, "Maximum signal-to-noise ratio array processing for space-time coded systems," in *IEEE Transactions on Communications*, vol. 50, no. 9, pp. 1419-1422, Sept. 2002.
- [15] Lei, Zhongding, Yongmei Dai, and Sumei Sun. "Ordered maximum SNR array processing for space time coded systems." *Electronics Letters* 39.6 (2003).
- [16] Li, Boyu, and Ender Ayanoglu. "Multiple beamforming with perfect coding." *IEEE Transactions on Communications* 60.6 (2012).
- [17] Wu, Xiaoxiao, Anthony Man-Cho So, and Wing-Kin Ma. "Rank-two transmit beamformed Alamouti space-time coding for physical-layer multicasting." *ICASSP*. 2012.
- [18] Liu, Jin, and Erry Gunawan. "Exact bit-error rate analysis for the combined system of beamforming and Alamouti's space-time block code." *IEEE Microwave and wireless components Letters* 14.8 (2004).
- [19] Kim, Joonsuk. "Interference suppression for high data rate STBC/SFBC with 1-bit feedback." *IEEE Communications Letters* 13.1 (2009).
- [20] Ji, Senshan, et al. "Multi-group multicast beamforming in cognitive radio networks via rank-two transmit beamformed Alamouti space-time coding." *2013 IEEE International Conference on Acoustics, Speech and Signal Processing*. IEEE, 2013.
- [21] A. F. Naguib, N. Seshadri and A. R. Calderbank, "Applications of space-time block codes and interference suppression for high capacity and high data rate wireless systems," *Conference Record of Thirty-Second Asilomar Conference on Signals, Systems and Computers* (Cat. No.98CH36284), 1998
- [22] N. Ghaedi, M.A.M. Shirazi & R.A Sadeghzadeh , " Spatial Interference Cancellation in MIMO Systems Using Side Lobe Canceller Structure." *Iran J Sci Technol Trans Electr Eng* 42 (2018).
- [23] Breed and .trauss, "A short proof of the equivalence of LCMV and GSC beamforming," in *IEEE Signal Processing Letters*, vol. 9,no. 6,pp. 168-169, June 2002.