

## Performance of Steel Beams Strengthened by Steel Pre-Stressed Cables and Memory Alloys under Static and Dynamic Loads

Reza Dadkhah Tehrani <sup>1</sup> .Davoud Tavakoli <sup>2,\*</sup>

### Abstract

With current progress in engineering science and in order to improve the performance of structures, the issue of strengthening of extant structures has caught many researchers' attention due to different reasons such as application change, loading increase after construction, and modification of regulations. In this study, the role of pre-stressed cables made of steel and Nitinol in a steel beam under dynamic and static loads along with some different mechanisms was examined. Initially, to locate optimal points, a three-floor structure was designed as the extant structure. Then, a beam was arbitrarily modeled using some different mechanisms that included strengthening with steel and Nitinol pre-stressed cables placed under the lower beam wing at the end of it in V-shaped form from the two sides of the beam to its center. Finally, the structure was analyzed and examined via non-linear static and dynamic analysis of time history. The obtained results finally indicated a positive role of applied mechanisms in the steel beam. Further, the results also showed that the performance of steel beam strengthened with steel and Nitinol pre-stressed cables was better than that of the beam with steel cables. In general, it might be observed that the deflection of the beam center in static and dynamic states had an average reduction of 55 and 60% when compared with the ordinary state.

**Key words:** Nitinol, Non-linear analysis of time history, Pre-stressed cables.

### Introduction

One way to increase the absorption of energy of forces exerted to structure parts is using dampers. Energy is typically exerted in two forms of kinetic and potential which is either absorbed or depreciated in different ways. If a structure lacks damping, its vibration will be continuous. However, due to the existence of damping in materials, vibration mitigates. The most important effect of damping is reduction of fluctuation range and building response to the imposed forces.

Hereby, a remarkable amount of this energy is wasted before the structure response reaches its ultimate limit. Energy dissipater might be placed in bracings, connections, non-structural parts, or other suitable places of buildings.

The possibility of mechanical control of structure by using a mechanism with considerable stiffness and damping properties that remains trivial residual strain and deformations after loading can not only reduce the rate of damages caused by

---

✉ Corresponding author: d.tavakoli@sru.ac.ir

1. PhD student, Shahrekord Branch, Islamic Azad University,

2. Civil Engineering Department, Shahid Rajaei Teacher Training University, Tehran, Iran

earthquake but also improve the buildings service. Many of existing structures need to be improved to be resistant against earthquake largely due to factors such as usage change, loading increase, gradual change of regulations, etc. Using energy absorbers in some parts of structure via a mechanism that, by using special deformations and mechanical acts, can absorb and depreciate a large amount of energy imposed to the structure can be effective in this regard. Additionally, applying advanced materials in these absorbers can play a special role in improving the performance of structures. One of these materials that have recently been utilized in building industry is memory alloys. Compared with common energy dissipaters, they have unique properties and advantages. High strength against corrosion and fatigue, capability of returning to primary state by using loading and temperature, capability of dissipating much energy, and also strain standing up to ten percent without remaining any residual strain are among these advantages. The most known and used type of these alloys is Nitinol which is a combination of nickel and titanium. The main property of these materials is their memory-formed and super-elastic behavior in this sense that they can tolerate big strain up to almost ten percent without creating any residual strain. They can also omit residual strains by using temperature.

The first recorded observations regarding shape memory alloy dates back to 1932 related to AU-CU alloy. After that, from 1949 to 1951, the thermos-elastic behavior was depicted and explained. In the 1960's, Buehler et al. conducted extensive research on nickel and titanium; and named their combination Nitinol (Buehler and Wang, 1967).

In 1991, Graesser and Cozzarelli used this alloy in civil engineering (related to dampers) for the first time. They delved into the effect of frequency and loading history

on the energy dissipation of Nitinol wires (Graesser and Cozzarelli, 1991). Also, Dolce and Cardone conducted a wide range of studies to examine the dependence of behavioural response on temperature, loading speed, and number of cycles. They offered different dissipating and returning dampers made of varying memory materials states that, together with experimental results, showed that combining them can lead to suitable responses against earthquake loadings (Dolce, M. and Cardone, D., 2001). Bruno and Valente also investigated the possibility of using these materials through analytical methods and using the failure index idea and simplified model of memory materials. Numerous non-linear analyses with gradual increase of earthquake severity on structures with steel and memory bracing as well as structures strengthened with rubber and memory segregators were done and structural and non-structural failure indexes and also members under these earthquakes were gained. The obtained results indicated the superiority of using memory segregators in mitigating the risks of earthquakes on structures (Bruno, S. and Valente, C., 2002).

Further, Mehdi Ghasemiyeh and Amir Kari studied the impact of structure height in seismic response of steel structures with new braces. They examined the two three- and six-floor structures proposed by Sabelli (Sabelli et al., 2001) in two different ways: once with braces ordinary against buckling and another time with advanced braces under seismic analyses. They eventually concluded that using memory alloys in venues where earthquake severity is estimated to be low is not recommended as these materials are costly and their response against weak earthquakes is almost equal with behavior of structures having BRB braces. They also reported that in places with severe earthquake, using braces with memory alloys should be prioritized provided that the structure height does not exceed three or four floors (Ghasemiyeh and Kari, 2011). As with

the improvement of seismic behavior of concrete shear wall structures using memory alloys, Ghasemiyeh and et al undertook studies and utilized super elastic behavior of this alloy in their studies to examine the possibility of seismic improvement of shear walls by memory alloys. Their proposed method included using fibers of memory alloys in bracing way (damper) in concrete shear walls in opening. They also employed the time history limited components method via software that had non-linear capabilities to be able to examine the structure behavior against earthquake. Their studies revealed that the models in which memory alloys were used as booster parts had 20% lower displacements while loading compared with basis models and trivial final and constant deformations remained in them which, in turn, improved the seismic behavior of the structure remarkably (Ghasemyeh et al., 2013).

Regarding the improvement of structure behavior and reduction of repairing costs after earthquake, Paulo Silva, et al., fulfilled studies. They showed that under El Centro earthquake and also when semi-active dampers with memory alloys are used, structure displacement (in terms of time) can remarkably be reduced and consequently, have considerable energy waste in structure which, in turn, mitigates the damages and costs after earthquake (Lobo et al., 2015). Similarly, Helbert, G et al, looked into the problems emanated from fatigue phenomenon on Nitinol cables. They examined two different dampers with NiTi wire several times using a vibrational desk. The obtained results indicated that dampers had good performance for both severe and small vibrations; and could perform well with energy absorption and return ability property (Helbert et al., 2018).

Zhang, et al. conducted an experimental study regarding the performance of beam with pre-stressed bars made of industrial (common) memory alloys. They used Nitinol bars in a beam with specific intervals and then put the beam under cyclic increasing loading. It was eventually

understood that remaining deformations in the beam was less than 16% and rotational deformations reduced to less than 8%. In general, the results indicated good performance of the beam (Zhang and Fu, 2009; Zhang et al., 2020).

Recently, using pre-stressed cables to fabricate and strengthen structures, especially bridges, has been among the economical and efficient ways in civil engineering science. conducted studies on 11 steel beams. They showed that employing high efficient steel cables decreased the general required steel and increased the structures' load carry capacity. Additionally, installing pre-stressed tendons can increase the structure loading capacity up to two times. In fact, if buckling is considered in structure, it can increase the load carry capacity up to 70 or 80%. Their studies also revealed that final performance and loading of metal beams increased markedly. Furthermore, comparing the pre-stressed forces of 98 KN and 196 KN showed that flexural capacity of steel I-shape beams improved in terms of stiffness. Installing a deviant can remarkably have affected the strengthening of steel beams. It could affect the pressure in the middle of opening and increased the flexural capacity of steel beam for 30 to 40 % (Park et al., 2010).

Wang, W et al. examined the flexural behavior of deep beams strengthened with some tendons. Displacement and stress responses were gained via Timoshenko beam theory. They loaded a deep I-shape beam once with three cables and another time with four cables. They also checked the cables once in pre-stressed way and another time in post-tensioned way. The findings uncovered that in all models perpendicular displacements reduced and also there was slight difference between the results of pre-stressed and post-tensioned methods. Also, it was understood that as the cables force and also the distance to the beam center increase, the beam performs better (Wang, W et al., 2015).

Given the conducted studies regarding memory alloys and their use in different

parts of structure, few studies have ever been carried out on strengthening of beams in steel structures. The present study, then, tries to strengthen the intended part behavior, which is under more-than-common loads for different reasons, by using a combination of different mechanisms and advanced materials and consequently, prevents replacement, destruction, and considerable costs. To be more specific, in this study, seven models with different mechanisms with steel and Nitinol pre-stressed cables have been compared and finally, the behavior of beam under static and dynamic loads have been investigated.

## 2. Theoretical basis and method

Memory alloys are those kinds of alloys that can restore their permanent deformations and strains and return to their primary form. Their behavior occurs on the basis of a phase transformation and crystalized structure change. Memory property in these alloys is by displacement of solid phase in which molecular rearrangement occurs. These alloys have two fixed phases: phase at high temperature, which is named Austenite, and has a cubic structure and is stronger largely due to its high symmetry. The second phase is at low temperature that is called Martensite and can be in twin or non-twin states. It has a monoclinic form and has a lower symmetry compared with Austenite. Martensite phase is of thermo-elastic with two properties of being slippery and having low energy which changes as strain and temperature slightly change. As alloy is cooled, phase change from Austenite to Martensite happens in absence of loading. The outcome of this phase change is not macroscopically observable. When material is heated in the Martensite phase, the process of phase return befalls. Four specific points have been highlighted in the phase change diagram of this alloy: 1:  $M_{os}$  temperature at which Martensite packs start to become bigger; 2:  $M_{of}$  temperature at which phase change from

Austenite to Martensite has occurred completely; 3:  $A_{os}$  temperature which is the beginning temperature of phase change from Austenite to Martensite; and 4:  $A_{of}$  temperature at which phase change from Martensite to Austenite has completed.

If mechanical loading on alloy occurs in twin Martensite phase, Martensite exits from its twin state and deforms (Graph 1). As soon as load is omitted, Martensite stays in that state. When alloy is heated higher than ( $A_{of}$ ) temperature, Martensite changes into Austenite. As a result, alloys returns to its primary form. What was depicted here is referred to as memory behavior. If loading occurs in Austenite phase and material is cooled, the phase change of Austenite to non-twin Martensite is observed that results in a strain of around 5-8%. However, reheating and reverse phase change causes the alloy to return to its primary form. The four specific points in the temperature-phase change diagram are known as transfer temperatures. These points hinge on the loading intensity and there is a linear relation between transfer temperature and loading intensity.

Phase change in alloy can also be created merely via mechanical loading those results in non-twin Martensite along with considerable strain. Now, if alloy temperature is above ( $A_{of}$ ), the alloy returns to its primary form as soon as loading stops. Figure 1 shows the whole process. Therefore, the material behavior is to some extent elastic which is called meta-elastic (Brinson, 1993; Kumar et al., 2020). Change of twin Martensite to non-twin Martensite is shown in figure 2.

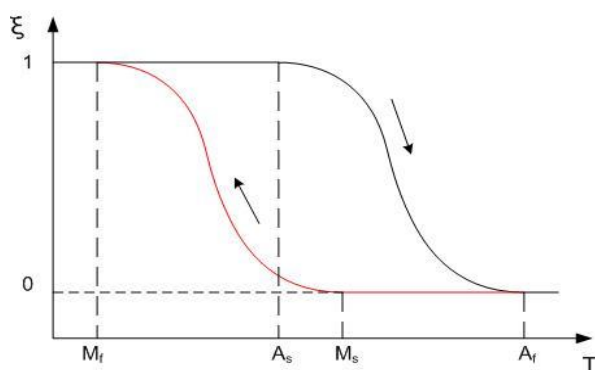

**Figure1:** Different phases of object in non-strain state (Kumar et al., 2020)

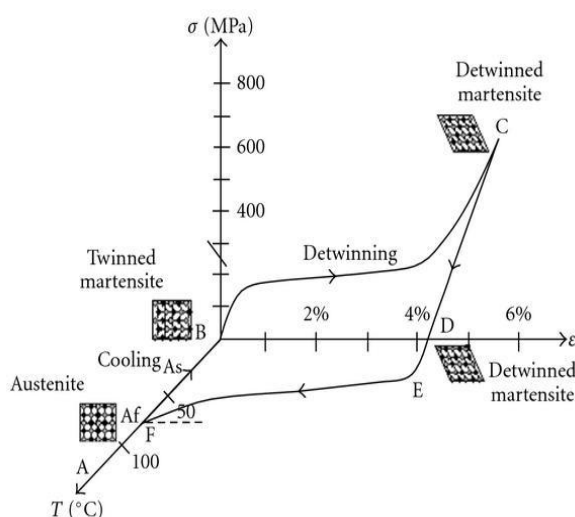

**Figure 2:** Change of twin Martensite to non-twin Martensite as a result of strain (Kumar et al., 2020)

To examine the performance and impact of using pre-stressed cables made of steel and Nitinol to strengthen beams in steel structures, as figure 1 of the study shows, first, a three-floor and three-opening structure was modeled to find the optimal points in ETABS software (figure 3). The dimensions of these optimal points were then extracted from ETABS and were used in Abaqus software (Abaqus, 2011). Tables 1 and 2 show the loading and the structure properties respectively. Further, Tables 3 and 4 present properties of steel and Nitinol (FEMA-273, 1997; FEMA-365, 2000). Additionally, to define the behavior of Nitinol alloy in Abaqus software, the Brinson subroutine was employed (Brinson,

L.C., 1993; Intel Fortran Compiler, 2011; Visual Studio, 2008).

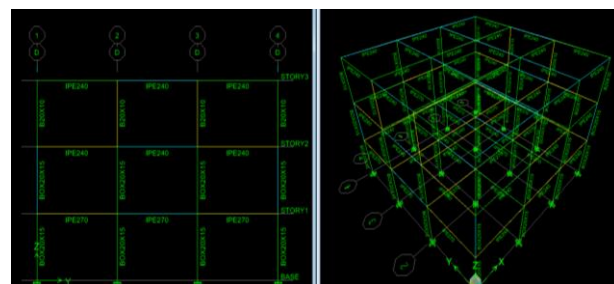

**Figure 3:** Dimensions of modeled frame in software

**Table 1:** Structure loading

Dead load	600	<b>650</b>
Live load	200	<b>150</b>
Wall load	700	<b>300</b>

**Table 2:** Properties of structure

Story	beam	column
1	IPE240	BOX18×18×2
2	IPE240	BOX18×20×2
3	IPE240	BOX18×20×2

**Table 3:** Properties of steel

Yield stress (Fy)	2400x104 kgf/m2
Final stress (Fu)	3600x104 kgf/m2
Unit weight (W)	7850 kg/m3
Modulud of Elasticity((E)	2.1x109 kgf/m3
Poisson's ratio (ν)	0.3
M (mass unit volume)	800 kg/m3

As it is seen in Figure 4, six different models have been used in this study to strengthen steel beam along with pre-stressed cables. It should also be mentioned that the only difference among these models is at the place of connection and that of cables in the beam. Also, the pre-stressed cables were once from steel and another time from nitinol. In state 2, cables are placed under the lower wing; in state 3, they are at the lower part of beam and above the lower wing; and in state 4, the cables are placed at the web of beam in V-form way. Finally, all states of 2 to 4 were analyzed once by using

steel cables and another time by using pre-stressed cables made of nitinol.

Table 4: Properties of nitinol

Moduli	Transfor mation Temperat ures	Transfor mation	Maxi mum Resid ual strain
$E = 67 \times 103$ Mpa	$M_f = 9^\circ\text{C}$	$C_M = 8$ Mpa/ $^\circ\text{C}$	$\epsilon_L = 0.067$
$D_m = 26.3 \times 103$ Mpa	$M_s = 18.4^\circ\text{C}$	$C_A = 13.8$ Mpa/ $^\circ\text{C}$	
$\Theta = 0.55$ Mpa/ $^\circ\text{C}$	$A_s = 34.5^\circ\text{C}$	$\epsilon_{crs} = 100$ Mpa	
	$A_f = 49^\circ\text{C}$	$\epsilon_{crf} = 170$ Mpa	

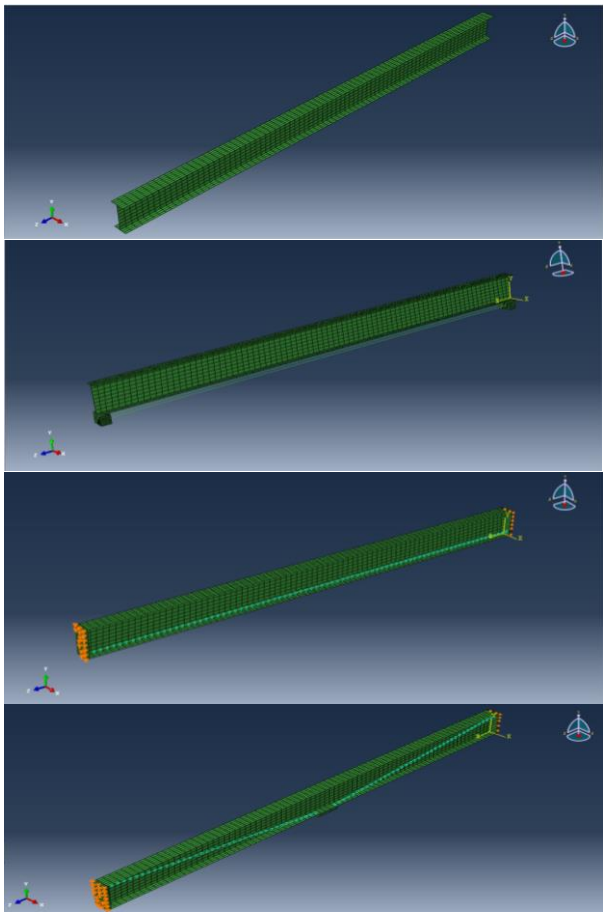

Figure 4: Beam without pre-stressed cable- **state 1**

Cables under the lower wing of beam- **state 2**

Cables in the lower part of beam and above the lower wing- **state 3**

Cables at the web of beam in V-form way- **state 4**

In this study, to analyze the beam, the dynamic and static non-linear time history method together with Imperial Valley acceleration was used (FEMA-440, 2005; Peer. berkeley, 2021). First, a three-floor frame and an opening with the width of 3.5 meters and height of 2.8 meters were modeled in Abaqus software. Then, to gain displacements in the studied beam, acceleration was achieved to the bases in terms of time. It should, however, be mentioned that modifications of acceleration such as base line and filtering were done through Seismosignal software. Also, to mitigate the calculations time by the software, a definition named strong duration was utilized. In order to estimate the record strong duration, different methods can be used. In this study, the Arias Intensity method was employed. This parameter, which is based on the maximum percentage of its cumulative value, can be measured via Seismosignal software (Blot B.A, 1969; Trifunac M.D and Brady, 1975).

### 3. Results and Discussion

After modeling the beam with different mechanisms and also after making the cables pre-stressed by imposing force, the models are first put under static load. As figure 5 show, the beam with varying mechanisms under static load experiences different displacements. In addition, at time of achieving mechanical load, the beam evinces different behaviors in different states. Figures 6 to 12 presents the displacement of the middle of beam in different states under dynamic load. Thus, in this stage, the beam first with steel pre-stressed cables and then with Nitinol pre-stressed cables (with three different states) is examined once under static and another time under dynamic loads.

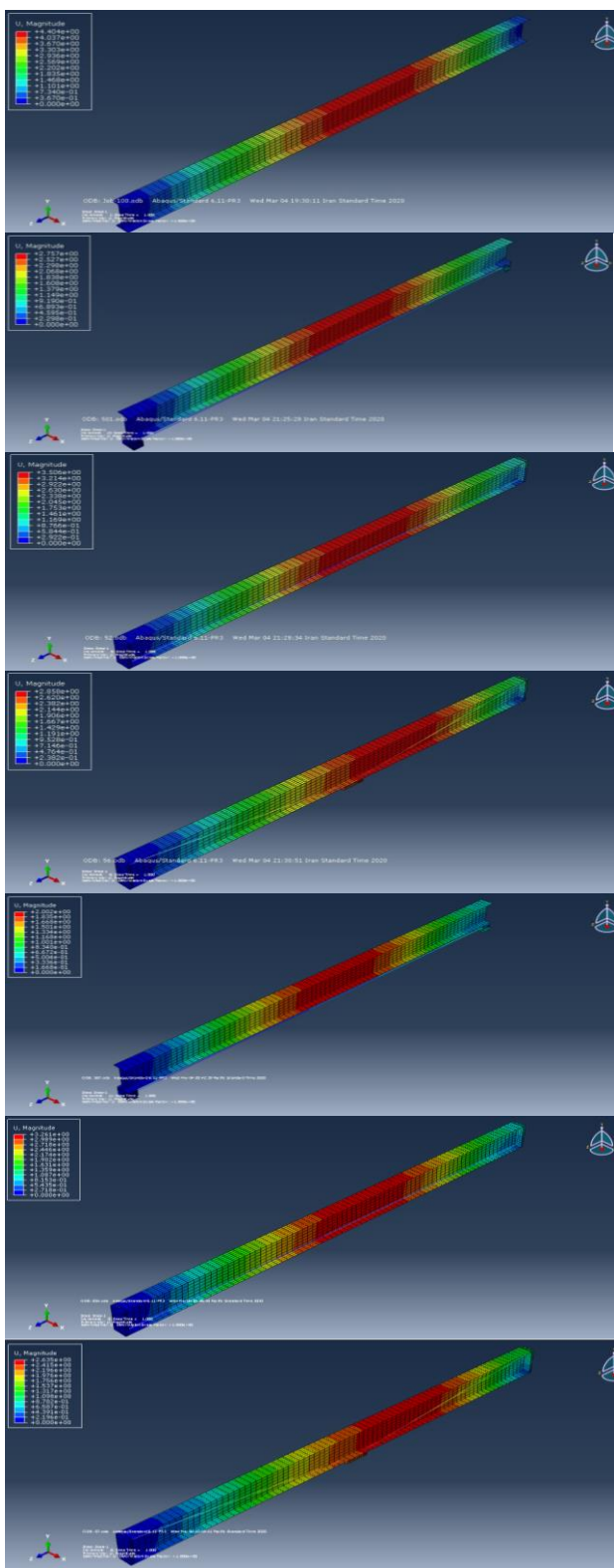

Figure 5: Beam without pre-stressed cables- state 1

Beam with steel pre-stressed cables (cables under the lower wing of beam) - state 2

Beam with steel pre-stressed cables (cables in the lower part of the beam and above the lower wing) - state 3

Beam with steel pre-stressed cables (cables in V-form way) - state 4

Beam with Nitinol pre-stressed cables (cables under the lower wing) - state 5

Beam with Nitinol pre-stressed cables (cables in the lower part of the beam and above the lower wing) - state 6

Beam with Nitinol pre-stressed cables (cables in V-form way) - state 7

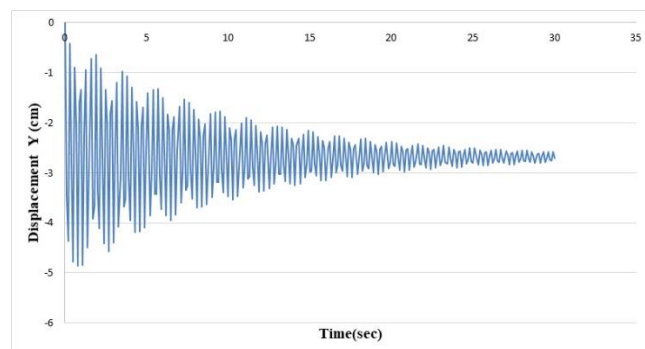

Figure 6: Deflection in the middle of beam to time – State 1: Without pre-stressed cables

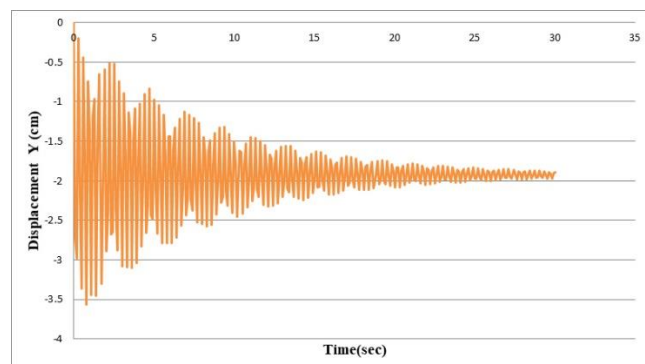

Figure 7: Deflection in the middle of beam to time – State 2: with steel pre-stressed cables (cables under the lower wing)

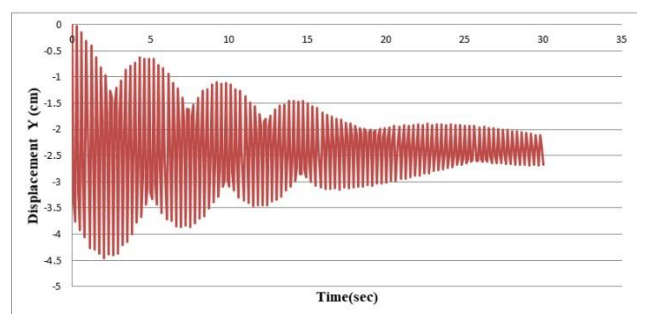

Figure 8: Deflection in the middle of beam to time – State 3: with steel pre-stressed cables

(cables in the lower part of the beam and above the lower wing)

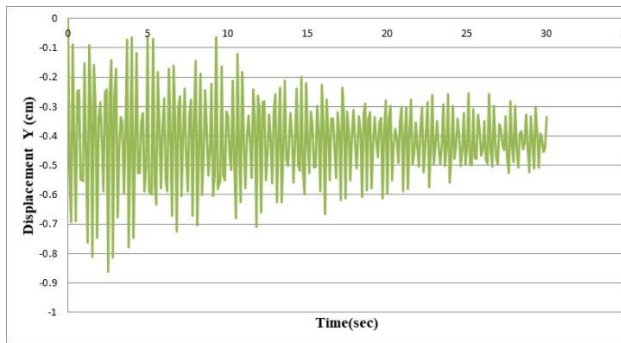

Figure 9: Deflection in the middle of beam to time – State 4: with steel pre-stressed cables (cables in V-form way)

(cables in the lower part of the beam and above the lower wing)

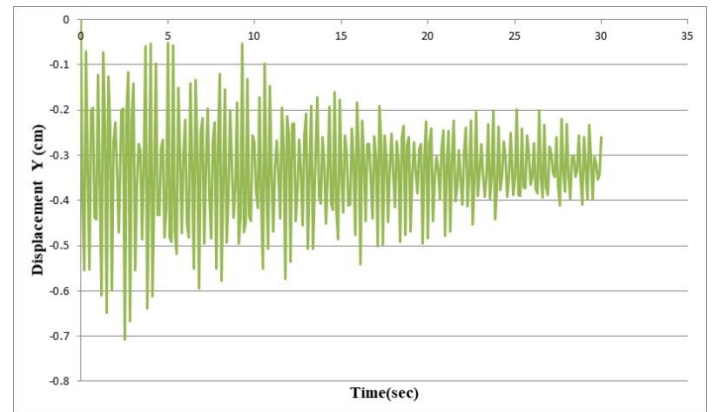

Figure 12: Deflection in the middle of beam to time – State 7: with Nitinol pre-stressed cables (cables in V-form way)

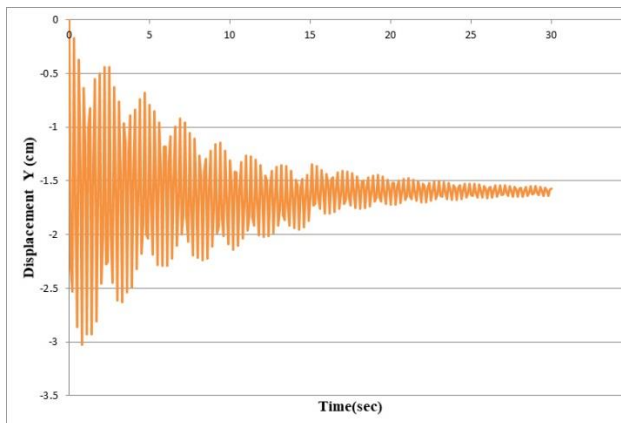

Figure 10: Deflection in the middle of beam to time – State 5: with Nitinol pre-stressed cables (cables under the lower wing)

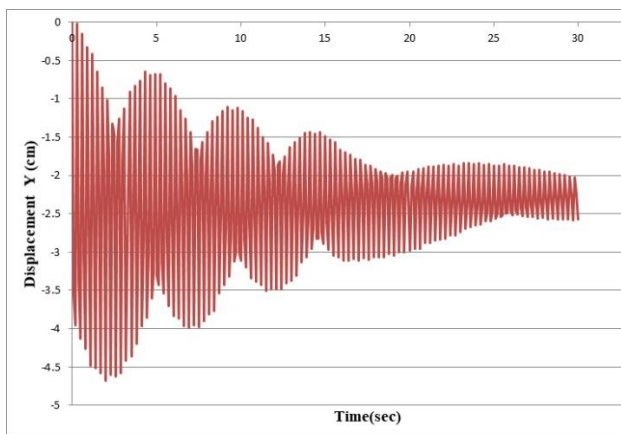

Figure 11: Deflection in the middle of beam to time – State 6: with Nitinol pre-stressed cables

After analyzing the obtained results, it is observed that the beam shows different behaviors and transformations under different mechanisms. The results obtained from the beam analysis in different states of static loading (Tables 5 and 6) indicate that in state 1 (when there was no strengthening mechanism), the most displacement is in the middle of beam for 4.4 mm. When the beam is under three strengthening mechanisms with steel cables under static loading, the highest displacement is in the middle of the beam in states 2, 3, and 4 (2.75, 3.5, and 2.85 respectively). Finally, when the beam is under three strengthening mechanisms with Nitinol cables under static loading, displacement in states 5, 6, and 7 (2, 3.26, and 2.63 respectively). The results of static loading on the beam in different states reveal that the beam in states 2, 3, and 4, compared with state 1 (with no strengthening), has had respectively 60, 28, and 54 Deflection reduction in the middle part. Further, when the beam is strengthened using Nitinol pre-stressed cables (states 5, 6, and 7), it has had respectively 37, 8, and 7 % Deflection reduction in the middle part compared with states 2, 3, and 4 (steel cables). This, in turn, can play a key role in reduction of damages and costs. In line with these findings, in a



similar study that was conducted on 11 steel beams, the results uncovered that using high efficiency steel cables can decrease the amount of required steel and help to increase the structures’ load carrying capacity. In addition, installing pre-stressed tendons can increase the loading capacity of structure for up to two times. In fact, in case of considering buckling in structure, it can increase the load carrying capacity for 70 to 80% (Zhang, N and Fu, C. C., 2009).

1	-	-
2	60	-
3	28	-
4	54	-
5	120	37
6	35	7
7	67	8

Table 5: Max deflection

Model	Max dis (mm)
1	4.40
2	2.75
3	3.50
4	2.85
5	2.00
6	3.26
7	2.63

Table 6: Percentage of deflection reduction in different states under static loading

states	Percentage of beam reduction compared to cableless mode	Percentage of beam reduction with NiTi cable compared to the same situation with steel cables
--------	---	---

Similarly, Figure 13 presents a general view of beam Deflection in different states of static loading. It can generally be stated that the lowest Deflection is related to states 5, 7, 2, 4, 6, and 3 respectively. In state 2, the cables have the furthest distance from neutral wire and consequently, show acceptable performance with both Nitinol and steel cables. In line with this, in state 3, since this distance reduces, beam has weaker performance compared with state 2. In another study in which the flexural behavior of deep beams strengthened with some tendons, the results revealed that in all models, perpendicular displacements reduce. The results also uncovered that as the cables power increases and distance to the beam center increases, beam performs better (Zhang, R et al., 2020).

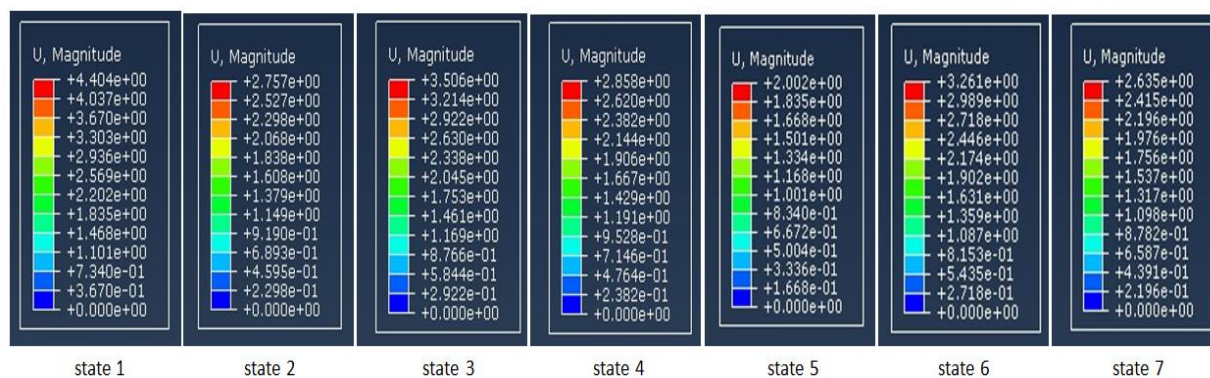

Figure 13: Beam deflection under static loading

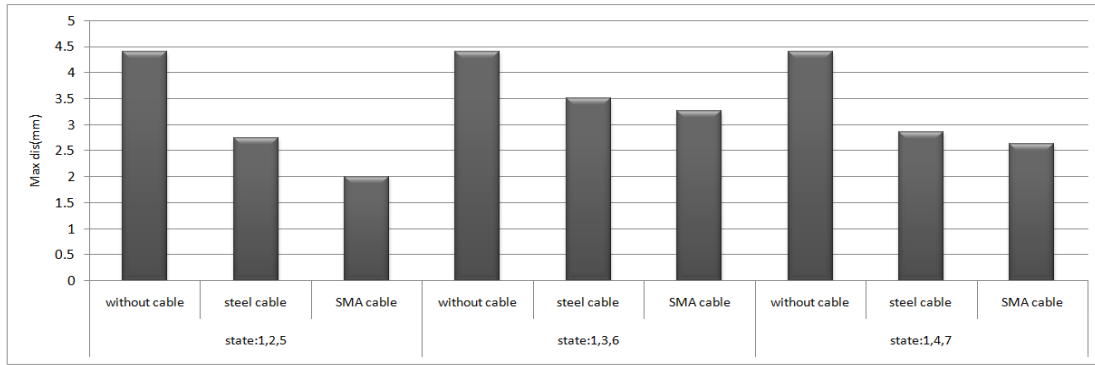

Figure 14: Comparison of the highest displacement of beam center in different states

As it can be seen, when the beam is under different dynamic loads (Figure15 to 19), considerable reduction of Deflection in both positive and negative directions can be seen in states 2, 5, 4, and 7. However, in states 3, and 6, not only no reduction of Deflection, compared with the strengthened beam state, occurs, but also in some cases displacement increase has also occurred. This implies that at time of loading in states 3 and 6, the used mechanism enhanced displacements in the beam behavior. Also, the comparison (Figure 20) indicates that the beam had its best performance in states 4 and then states 2 and 3.

Given the comparison, it is noticed that when Nitinol cables are used to strengthen beam, the best performance can be expected in state 4 and then states 2 and 3. According to figure 29, the best performance of beam is related to state 4 under dynamic loads as it has the lowest mean of displacements. Therefore, it can finally be concluded that the beam performed weakly in states 4 and 7, performed relatively well in states 2 and 5, and performed the best in states 4 and 7 in both static and dynamic cases. In the end, given the obtained results and comparisons, it might be contended that given the high cost of memory alloys, using Nitinol pre-stressed cables are economical only in states 2 and 4 and in other cases they should not be used in light of their low energy absorption and considerable displacements. In a relatively similar study (but laboratory one) regarding the performance of beam along with pre-stressed bars made up of industrial memory

alloys that have Nitinol bars in specific distances and are then put under increasing cyclic loading, it was understood that remaining displacements in the beam was less than 0.16% and rotational displacements were less than 18%. In general, the results of current study indicated good performance of beam with this alloy (Lobo, P et al., 2015).

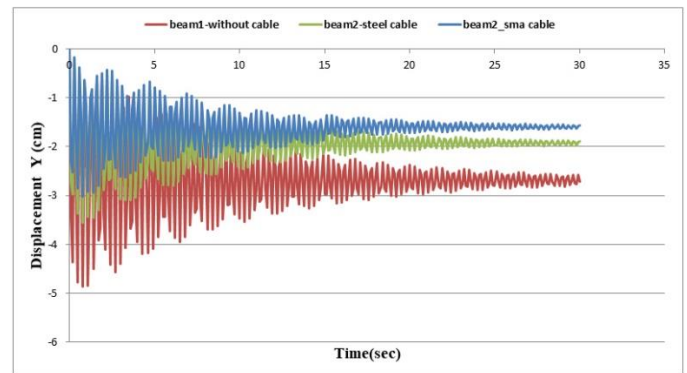

Figure 15: Comparing beam deflection under dynamic loading in states 1, 2, and 5

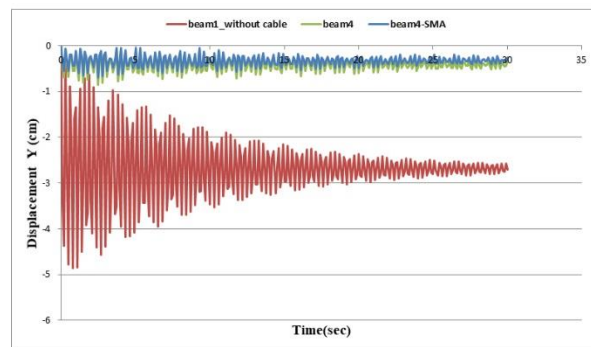

Figure 16: Comparing beam deflection under dynamic loading in states 1, 3, and 6

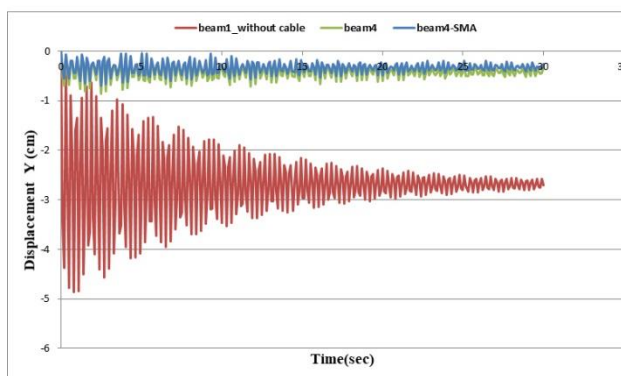

Figure 17: Comparing beam deflection under dynamic loading in states 1, 4, and 7

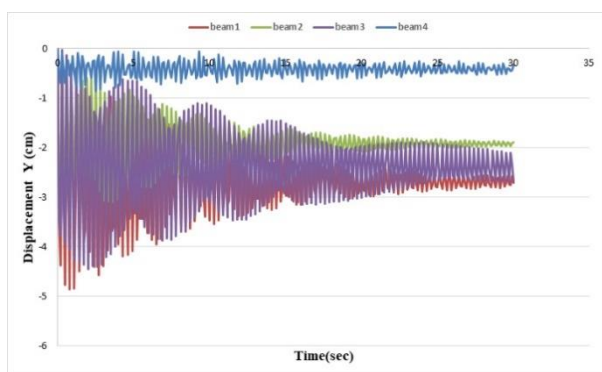

Figure 18: Comparing the deflection of beam center when steel pre-stressed cables are used

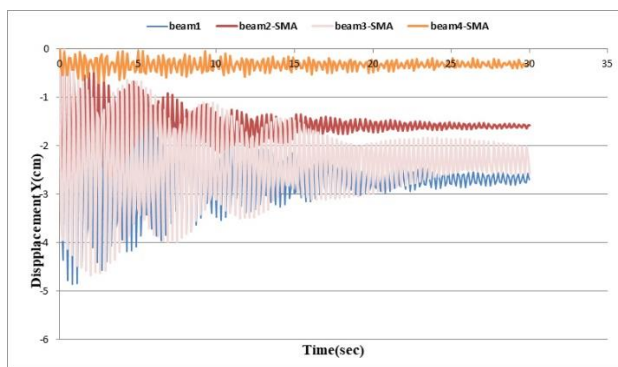

Figure 19: Comparing the deflection of beam center when Nitinol pre-stressed cables are used

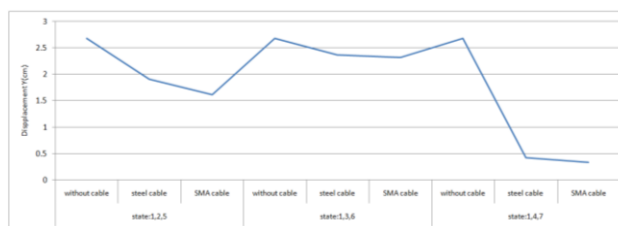

Figure 20: Comparing displacements fluctuation range mean in the middle of beam under dynamic loading

#### 4. Conclusions

This study looked into the role of steel and nitinol pre-stressed cables in a steel beam under static and dynamic loads together with some varying mechanisms that included strengthening along with steel and nitinol pre-stressed cables inserted under the lower wing of beam, at the end of beam web, and in V-form way from two sides of beam to the beam center. The findings revealed that pre-stressed cables made of steel and especially those of nitinol reduced displacements and improved the structure’s behavior. Using nitinol, in view of its properties especially its super elastic property, can increase the absorption of energy of the structure under static and dynamic loads. Applying this alloy in some parts of structure is likely to remove many of restrictions pertinent to replacement, damage, destruction, and also uneconomical costs which, in turn, mitigates varying kinds of damages. In general, it might be observed that the deflection of the beam center in static and dynamic states had an average reduction of 55 and 60% when compared with the ordinary state.

#### References

Abaqus, Inc, ABAQUS User Manual, V6.11, 2011

Blot B.A., 1969. Duration of Strong Motion, Proc. 4th World Conf. Earthquake Eng. pp.1304-1315

Brinson, L.C., 1993. One-dimensional constitutive behavior of shape memory alloy: thermomechanical derivation with non-constant material functions under defined martensite internal variable. *Journal of Intelligent Material Systems and Structures*, pp.229–242.

Bruno, S., Valente, C., 2002. Comparative response analysis of conventional and innovative seismic protection strategies. *Earthquake Engineering and Structural Dynamics*, Volume31, pp. 1067-1092.

Buehler, WJ., Wang, FE., 1967. A summary of recent research on the nitinol alloys and their potential application in ocean

- engineering. *Journal of Ocean Eng.*, Volume 1, pp. 105-120.
- Dolce, M., Cardone, D., 2001. Mechanical behavior of shape memory alloys for seismic applications –2. Austenite NiTi wires subjected to tension. *International Journal of Mechanical Sciences*, Volume. 43, pp.
- FEMA-440., 2005. Improvement of nonlinear satatic seismic analysis rocedures. Federal Emergency Management Agency.
- FEMA-273., 1997. NEHRP guidelines for the seismic rehabilitation of buildings.Federal Emergency Management Agency. Washington, D.C.
- FEMA-365., 2000. Prestandardand commentary for these seismic rehabilitation of buildings. Federal Emergency Management Agency.
- Ghasemyeh, M., Kari, A., 2011. The effect of structural height on the seismic response of steel structures with new braces, *Civil engineering and survey journal*, Volume 45(4), pp.467-478. (In Persian)
- Ghasemyeh, M., Ghodrati, M., Nojumi, S.A., 2013. Seismic Enhancement of Coupled Shear Walls Using Shape Memory Alloys, *Journal of Civil Engineering and Science*, Volume 2 Iss. 2, pp. 93-101
- Graesser E. J., Cozzarelli F.A., 1991. Shape Memory Alloys as new materials for seismic isolation. *Journal of Engineering Mechanics*, Volume 117, No. 11, pp. 2590-2608.
- Helbert, G. Dieng, L. Arbab Chirani, S. Saint-Sulpice, L. Lecompte, T. Calloch, S. Pilvin, P., 2018. Investigation of NiTi based damper effects in bridge cables vibration response: Damping capacity and stiffness changes. *Journal of constructional steel research*, Volume 165, pp. 184-197.
- <http://peer.berkeley.edu/smcat/search.html>. (PEER Database of Strong Ground Motion)
- Intel Fortran Compiler, V11.1.048, 2011
- Kumar, S., Kumar, I.A., Marandi, L., Sen, I., 2020. Assessment of small-scale deformation characteristics and stress-strain behavior of NiTi based shape memory alloy using nanoindentation. *Acta Mater*, Volume 201, pp.303–315.
- Lobo, P. S., Almeida, J., & Guerreiro, L., 2015. Semi-active damping device based on superelastic shape memory alloys. *In Structures Elsevier*. Volume. 3, pp. 1-12.
- Park, S., Kim, T., Kim, K., & Hong, S. N., 2010. Flexural behavior of steel I-beam prestressed with externally unbonded tendons. *Journal of constructional steel research*, Volume 66(1),pp. 125-132.
- Sabelli, R., et al., 2001. Investigation of the Nonlinear Seismic Response of Special Concentric and Buckling Restrained Braced Frames and Implications for Design. Report to EERI, FEMA/EERI Professional Fellowship Report.
- Trifunac M.D., Brady A.G., 1975. A study on the duration of strong earthquake ground motion, bulletin of Seismological Society of America, Volume 65,pp.581-626
- Visual Studio 2008, service Pack1,2008
- Wang, W., Chan, T. M., & Shao, H., 2015. Seismic performance of beam-column joints with SMA tendons strengthened by steel angles. *Journal of Constructional Steel Research*, Volume 109, pp.61-71.
- Zhang, N., and Fu, C. C., 2009. Experimental and theoretical studies on composite steel-concrete box beams with external tendons. *Engineering structures*, Volume 31(2), pp.275-283.
- Zhang, R.; Wang, S., Tian, J., Chen, K., Xue, P., Wu, Y., Chou, W., 2020. Effect of PEW and CS on the Thermal, Mechanical, and Shape Memory Properties of UHMWPE. *Polymers*, 12, 483.