

Presenting a New Fault Current Limiter Structure to Reduce the Over-voltage of the DFIG DC Link in the Voltage Sag Condition

Mohsen Ghorbani¹, Babak Mozafari², Mehdi Firouzi^{1,3*} and Farzad Golshan¹

Abstract – Wind farms equipped with Doubly-Fed Induction Generator (DFIG) are very sensitive to sudden changes in the voltage at their terminals, and when a fault occurs, the transmission power from the rotor of generator to the grid is reduced and causes a sudden increase in the voltage of the DC link capacitor and the rotor current increase in the mentioned current or voltage causes severe damage to the generator converter. In recent years, one of the devices that researchers have been focused on to prevent this problem is Fault Current Limiters (FCL). In this paper, a new FCL structure is presented, which by designing a suitable control system, without losing the control of the wind turbine, the FCL prevents the sharp increase in DC link capacitor voltage of DFIG. To evaluate the performance of this limiter, simulations are performed in PSCAD/EMTDC software and compared with a classic method.

Keywords: DFIG-based wind farm, Fault Current Limiter, DC link over-voltage

1. Introduction

Due to the increasing influence of wind farms in the power grid, operators of wind generators should notice requirements and grid codes.[1,2] Several studies have been presented in the field of improving the ability Low Voltage Ride Through and also reducing the amount of short circuit current caused by connecting wind generators to the grid. In this section, the methods presented to improve the ability Low Voltage Ride Through (LVRT) in wind farms have been examined.

The occurrence of a fault in the line leads to a severe voltage drop at the terminal of the wind farms, and the wind farms should remain in the circuit during the voltage drop according to the grid codes defined by operators. Voltage drop in wind farms equipped with DFIG increases the transient current in the rotor at the start and end of the fault and increases the DC link voltage during the fault occurrence. [3,4]

Various methods have been used in literature to increase the ability of low voltage ride through of wind farms, which

include:

One of the proposed solutions to improve the passage of voltage drop conditions is the use of Flexible AC Transmission Systems (FACTS) devices with parallel connection, including Static VAR Compensator (SVC) and Static synchronous Compensator (STATCOM). as induction generators are used in wind farms and these generators need to supply reactive power after fixing the fault, FACTS devices are used to supply their required reactive power, and this improves the ability to overcome voltage drop conditions. We will introduce some studies that have been conducted in this field. In reference [5], a control system based on the coordination between the positive and negative sequence of voltage belonged to the junction of wind farms for STATCOM has been proposed to improve the ability to overcome voltage drop conditions in asymmetrical and symmetrical faults. The results show that this method is effective for improving the ability to Low Voltage Ride Through.

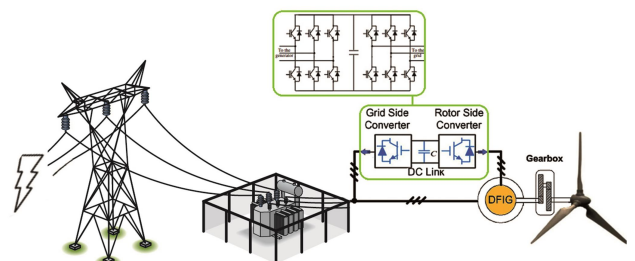

Fig.1. Schematic of grid connected DFIG wind farm

¹ Department of Electrical Engineering, Karaj Branch, Islamic Azad University, Karaj, Iran

² Department of Electrical Engineering, Science and Research Branch, Islamic Azad University, Tehran, Iran

^{3*} Corresponding Author : Department of Electrical Engineering, Abhar Branch, Islamic Azad University, Abhar, Iran

Email: m_firoziabhari@yahoo.com

Received: 2022.07.23; Accepted: 2022.09.16

2 Presenting a New Fault Current Limiter Structure to Reduce the Over-voltage of the DFIG DC Link in the Voltage..

In reference [6], the direct torque control method is used to reduce the torque fluctuations after removing the fault and also to reduce the mechanical pressure on the rotor. The problem of this method is that it is ineffective during the occurrence of a fault and it also does not prevent the voltage drop during a fault. Another method that has received a lot of attention is the use of Series Dynamic Braking Resistor (SDBR). This method has good efficiency in terms of simplicity and effectiveness in improving the ability to overcome fault conditions and also satisfy the requirements set by network operators. [7] In this study, the performance of SDBR and STATCOM has been compared in improving the ability of LVRT. The results show that SDBR effectively improves the ability to Fault Ride Through (FRT). This method not only reduces the voltage drop during the fault, but by consuming the wind generator's production power, it helps its stability. Also, according to the obtained results, the impact of 0.01 pu SDBR is similar to 0.4 pu of parallel reactive power compensation using STATCOM, to improve the LVRT. But the main drawback of this method is the transient state when the resistor is inserted and also the delay of its switching, which is usually mechanical. In the article [8], a new configuration called Modulated SDBR (MSDBR) is used to improve the ability of FRT, which uses an electronic switch with a Pulse Width Modulation (PWM) control system instead of a mechanical switch to improve the LVRT.

In the article [9], a controllable parallel capacitor has been used in the DC link of the DFIG to improve the LVRT ability. In this method, by controlling the capacitor switching, the overvoltage of the DC link is reduced and the low voltage ride through is improved.

In reference [10], a structure called Continuous Variable SDBR (CV-SDBR) is used. In this method, semiconductor switches are used instead of mechanical switches to apply SDBR in the circuit, and in reference [11], the combination of SDBR and STATCOM is used to improve the LVRT. According to the results of this article, the use of a combination of two methods effectively improves the LVRT, but it leads to an increase in costs.

Another proposed method is the pitch angle controlling of the wind turbine blades [12]. To improve the ability LVRT, this method is economically less expensive, but the response of the blade angle controlling is very slow compared to other devices, and it is not efficient alone when strong voltage drops occurs. In the article [13], a control system is presented to coordinate turbine blade angle and STATCOM control systems to enhance the ability of LVRT in constant speed wind generators. The results of investigations in this method show that the ability to

overcome voltage drop conditions in wind farms is improved by reactive power compensation and the timely operation of the blade angle control system.

Other solutions provided are the use of Static Synchronous Series Compensator (SSSC) and Dynamic Voltage Restorers (DVR). In reference [14], these compensators have been used to improve stability and power flow management. The control system used in SSSC makes improving in the stability and power flow management when the fault occurs. Reference [15] has used DVR to improve the LVRT in wind generators. In this method, a two-stage control system has been used, first stage to compensate the voltage drop and the second stage for quickly recovering of the voltage. Another effective tool to improve the LVRT is Fault Current Limiters (FCL), which has become very common in recent years. The basis of their operation is to insert impedance into the line. In this paper, a new FCL structure is presented, which improve the LVRT and prevents the sharp increase in DC link capacitor voltage of DFIG.

This research focuses on the wind farm equipped with DFIG and as shown in Fig.1 stator is directly connected and its rotor is indirectly connected to the grid through a back-to-back converter. As a result, the frequency and amplitude of the stator is fixed and the active and reactive power exchanged between the stator and the rotor to the grid is controlled by adjusting the amplitude and frequency of the injected current to the rotor. The main task of the grid side converter is to control the DC link voltage at a constant value, and the rotor side converter is responsible of controlling the active and reactive power of the stator. The DFIG power control method is based on Field Oriented Control FOC method.[16,17] The rotor windings are fed by back to back voltage source converters that are connected through the DC link.

2. DFIG active and reactive power control with FOC strategy

The FOC technique has been often used as a well-known and classic method for DFIG control in many references. [16-18] In this method, the DFIG equations are studied in the synchronous rotating reference frame in a way that its d axis corresponds to the stator field vector that rotates with synchronous speed and its q axis corresponds to the stator voltage vector. The rotor current is divided into two vertical and independent components of d and q in the rotating reference frame. The q component of the current is used for control of active power, while the d component is used to control reactive power. As shown in Fig. 2 the active and reactive powers of the DFIG can be controlled by adjusting

the current and voltage of the rotor windings. In this case, by using vector control, in which the d-axis of the reference frame is selected in direction of the stator field, the active and reactive powers are controlled completely independently by the components of the rotor current.

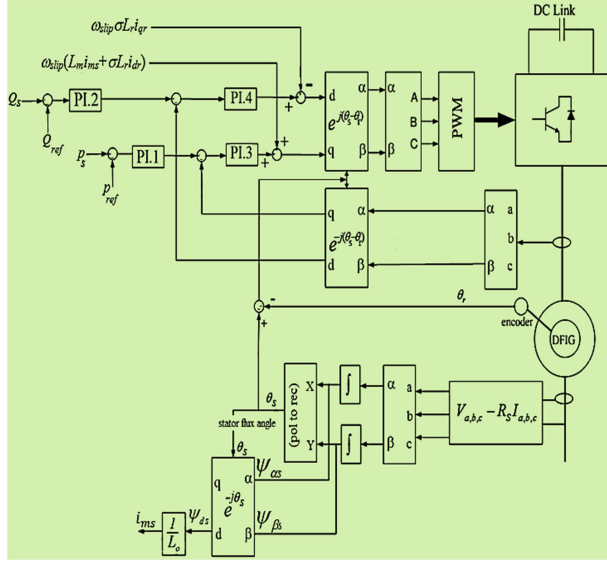

Fig. 2. DFIG rotor side converter control system

3. Proposed Fault Current Limiter structure

The proposed FCL structure is shown in Fig. 3, it is based on the reference [19] fault current limiter, but instead of the inductor, a capacitor has been substituted. Proposed limiter consists of the following components:

- 1-Semiconductor GTO switch (S)
- 2-Diode bridge rectifier including D1 to D4
- 3-parallel capacitor C_{sh}
- 4-varistor

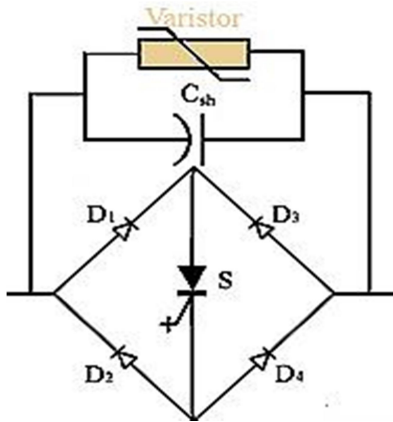

Fig. 3. Structure of proposed FCL

When a short circuit occurs in the transmission line, the terminal voltage of the wind farm reaches the threshold

value, at this time the control system turns off S switch and the capacitor is placed in the circuit. When the short circuit current passes through the capacitor, the voltage of the capacitor exceeds the operating voltage of the varistor, and in this case, the varistor is activated and limits the current, so the ability of Fault Ride Through increases. When the limiting controller detects a voltage drop, S switch opens and the line current is directed to the path of the capacitor and varistor. In this case, the voltage of the capacitor is increased and when the voltage of the capacitor becomes greater than the operating voltage of the varistor, the varistor is activated. In this case, the line current passes through the capacitor and varistor, and the FCL, which has a resistive feature, eliminates the accelerating energy of the generator so that the wind farm accomplishes transient stability in the fault condition. The varistor also protects the limiter against over voltage during switching.

4. Simulation results

In this study, a wind farm equipped with DFIG is simulated in PSCAD/EMTDC software. Fig. 4 shows the studied system, in which the location of the wind farms and the limiter is demonstrated. In Fig. 4, a 20^{MW} wind farms are connected to the grid, as integrated. The ability of the FCL to improve the fault ride through is measured under a three phase to ground fault conditions. The parameters of the simulated system are shown in Table 1.

Table 1. Simulated system parameters

Induction Generator	Nominal power	2MVA
	Voltage	700V
	Frequency	50 Hz
	Constant of inertia	2s
	Resistance of stator	0.006 Ω
	Stator leakage reactance	0.078 Ω
	Resistance of rotor	0.016 Ω
FCL	Rotor Leakage-reactance	0.1 Ω
	Mutual-Reactance	2.5 Ω
Grid	C_{sh}	100uF
	V_K	60kV
	Voltage	132 kV
Transmission Line	Frequency	50Hz
	X/R ratio	5
Transmission Line	Resistance	0.272 Ω/km
	Reactance	0.372 Ω/km
	Length	100 km

The fault in the grid happens hypothetically at the beginning of the line. In this study, to evaluate the capability of LVRT, a wind farm equipped with a doubly-fed induction generator has been simulated. The performance of the proposed limiter has been compared with the RL fault current limiter and investigated under

4 Presenting a New Fault Current Limiter Structure to Reduce the Over-voltage of the DFIG DC Link in the Voltage..

three phase to ground fault conditions in the transmission line. The wind speed at the time of simulation is constant and equal to 14 m/s , and the fault occurred in the third second and its impedance is $1\text{ m}\Omega$ and the duration of the fault is 150 ms . The simulations are considered in three modes as without limiter, Connection with RL fault current limiter and Connection with proposed limiter.

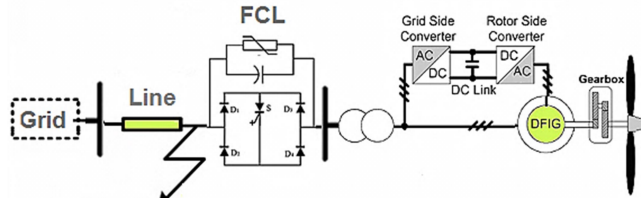

Fig. 4. Schematic of simulated system

Fig. 5 shows the PCC bus voltage for all conditions. According to the figure, the use of the proposed limiter leads to a lower voltage drop compared to the RL fault current limiter.

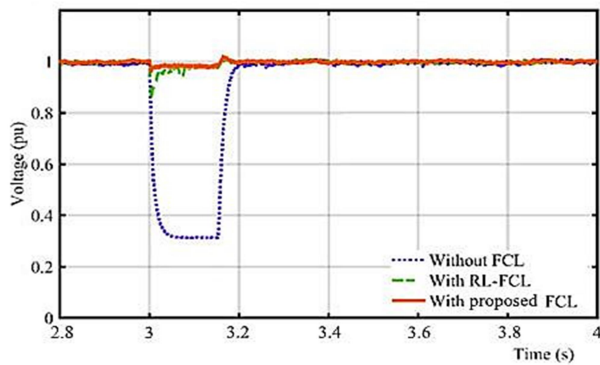

Fig. 5. DFIG-based wind farm terminal voltage

Fig. 6 shows the DFIG rotor current for all states. In this condition, the rotor current increases to 4.1 pu at the beginning of fault in without fault current limiter state, respectively. In RL fault current limiter state, the rotor current reaches 4 pu at the time of fault initiation. It is while using the proposed limiter, greatly reduces the fluctuations of the rotor current and prevents damage to the rotor winding.

Fig. 7 shows the DC link voltage for all conditions. As shown in this figure the DC link voltage increases to 1.7 pu for RL fault current limiter mode in the fault condition, While the proposed limiter keeps the DC link voltage almost constant during the fault.

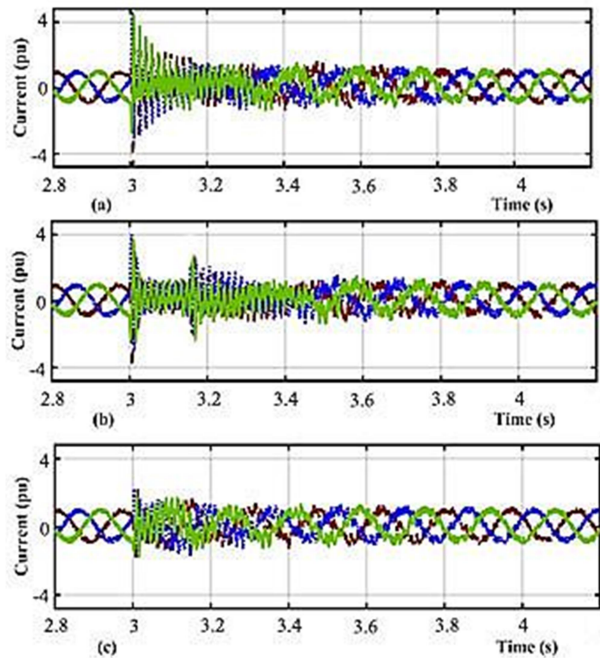

Fig. 6. rotor current of DFIG-based wind farm a)Without FCL mode, b)With RL FCL mode, c)With proposed FCL

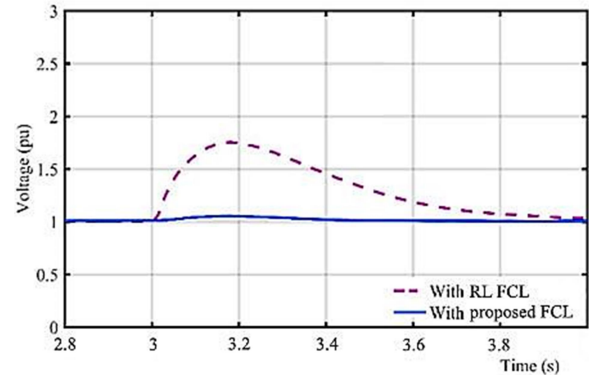

Fig. 7. DFIG-based wind farm DC link voltage

5. Conclusion

Due to the increasing penetration of DFIG-based wind farms in the power system and according to the grid codes which determined by the grid operators, wind generators should help the stability of the grid when fault occurs in the system. In this article, a Fault Current Limiter with a new structure compared with a classic FCL called RL Fault Current Limiter. When a fault occurs in the line, the control system acts quickly and maintains stability and helps the grid to recover the voltage, and not only prevents the sudden increase in voltage of the DFIG-based wind farm DC link but also prevents the severe fluctuations in the DFIG rotor current and damage to control system equipment. The results were compared under the same conditions with the RL FCL and showed that the proposed limiter has a better performance than the RL Fault Current Limiter.

References

- [1] Transmission Code. Network and System Rules of the German Transmission System Operators, Verband der Netzbetreiber VDNe.v. beim BDEW. [Online]. Available: www.bdew.de/ Aug. 2007
- [2] F. Iov, A. D. Hansen, P. Sørensen, and N. A. Cutululis, "Mapping of grid faults and grid codes," Risø Nat. Lab., Tech. Univ. Denmark, Copenhagen, Denmark, Rep. Risø-R-1617-(EN), Jul. 2007
- [3] J. Lopez, P. Sanchis, X. Roboam, and L. Marroyo, "Dynamic Behavior of the Doubly Fed Induction Generator During Three Phase Voltage Dips," *IEEE Trans. Energy Convers.*, 2007, 22(3), pp. 709-717
- [4] M. Rahimi and M. Parniani, "Transient Performance Improvement of Wind Turbines With Doubly Fed Induction Generators Using Nonlinear Control Strategy", *IEEE Trans. Energy Convers.*, 2010, 25(2), pp. 514-525
- [5] C. Wessels, N. Hoffmann, M. Molinas, and F. Wilhelm Fuchs.: 'STATCOM Control at Wind Farms With Fixed-Speed Induction Generators Under Asymmetrical Grid Faults'. *IEEE Transactions on Industrial Electronics*, 2013, 60(7), pp. 2864 – 2873
- [6] J.A. Suul, M. Molinas, T. Undeland.: 'STATCOM-Based Indirect Torque Control of Induction Machines During Voltage Recovery After Grid Faults', *IEEE Transactions on Power Electronics*, 2010, 25(5), pp. 1240-1250
- [7] A. Causebrook, D. J. Atkinson, and A. G. Jack.: 'Fault Ride-Through of Large Wind Farms Using Series Dynamic Braking Resistors', *IEEE Transaction on Power System*, 2007, 22(3), pp. 966 – 975
- [8] P. Huang, M. Sh. El Moursi, S. A. Hasen.: 'Novel Fault Ride-Through Scheme and Control Strategy for Doubly Fed Induction Generator-Based Wind Turbine', *IEEE Transactions on Energy Conversion*, 2015, 30(2), pp. 635 – 645
- [9] L. Huchel, M. S. El Moursi , H. H. Zeineldin.: 'A Parallel Capacitor Control Strategy for Enhanced FRT Capability of DFIG', *IEEE Transactions on Sustainable Energy* , 2015, 6(2), pp. 303 – 312
- [10] Kh. Goweily, M. Sh. El Moursi, M. Abdel-Rahman, M. A. L. Badr.: 'Voltage booster scheme for enhancing the fault ride-through of wind turbines', *IET Power Electronics*, 2015, 8(10), pp. 1853-1863
- [11] S. M. Muyeen.: 'A Combined Approach of Using an SDBR and a STATCOM to Enhance the Stability of a Wind Farm', *IEEE Systems Journal* 2015, 9(3), pp. 922–932
- [12] S. M. Muyeen, M. H. Ali, R. Takahashi, T. Murata, and J. Tamura.: 'Transient stability enhancement of wind generator by a new logical pitch controller', *IEEE Transactions on Power and Energy*, 2006, 126(8), pp. 742–752
- [13] M. J. Hossain, H.R. Pota , V. A. Ugrinovskii and R.A.Ramos.: 'Simultaneous STATCOM and Pitch Angle Control for Improved LVRT Capability of Fixed-Speed Wind Turbines', *IEEE Transactions on Sustainable Energy*, 2010, 1(3), pp. 142–151
- [14] L. Wang, and Q. S. Vo.: 'Power Flow Control and Stability Improvement of Connecting an Offshore Wind Farm to a One-Machine Infinite-Bus System Using a SSSC', *IEEE Transactions on Sustainable Energy*, 2013, 4(2), pp. 358 - 369
- [15] A. E. Leon, M. F. Farias, P. E. Battaiotto, J. A. Solsona.: 'Control Strategy of a DVR to Improve Stability in Wind Farms Using Squirrel-Cage Induction Generators', *IEEE Transactions on Power System*, 2011, 26(3), pp. 1609 – 1617
- [16] F. K. A. Lima, A. Luna, P. Rodriguez, E. H. Watanabe, and F. Blaabjerg, "Rotor voltage dynamics in the doubly fed induction generator during grid faults," *IEEE Trans. Power Electron.* 2010, 25(1), pp. 118–130
- [17] J. Liang, W. Qiao, and R. G. Harley, "Feed-forward transient current control for low-voltage ride-through enhancement of DFIG wind turbines," *IEEE Trans. Energy Convers.* 2010, 25(3), pp. 836–843
- [18] J. Yao, H. Li, Y. Liao, and Z. Chen, "An improved control strategy of limiting the DC-link voltage fluctuation for a doubly fed induction wind generator," *IEEE Trans. Power Electron.* 2008, 23(3), pp. 1205–1213
- [19] A. R. Fereidouni, B. Vahidi and T. Hosseini Mehr, "The Impact of Solid State Fault Current Limiter on Power Network With Wind-Turbine Power Generation," in *IEEE Transactions on Smart Grid*, 2013, 4(2), pp. 1188-1196.