

Research Paper

Evaluation of Thermal Barrier Coating in Fatigue Life for an Aluminum Alloy Piston with Considering Residual Stress

H. Ashouri *

Department of Mechanical Engineering, Varamin-Pishva Branch, Islamic Azad University, Tehran, Iran

Received 29 June 2023; accepted 28 August 2023

ABSTRACT

Nowadays, engine components are subjected to higher loads at elevated temperatures due to the increasing requirements regarding weight, performance, and exhaust gas emission. Thus, fatigue due to simultaneous thermal and mechanical loading became a determinant among the damage forms. The effect of a thermal barrier coating (TBC) on the thermal stress and fatigue life in a gasoline engine piston with considering stress gradient was studied. For this purpose, coupled thermo-mechanical analysis of a gasoline engine piston was performed. Then fatigue life of the component was predicted using a standard stress-life analysis and results were compared to the original piston. The results of finite element analysis (FEA) indicated that the stress and number of cycles to failure have the most critical values at the upper portion of piston pin and piston compression grooves. The obtained thermo-mechanical analysis results proved that the TBC system reduces the stress distribution in the piston by about 2.4 MPa and 8.5 MPa at engine speeds of 1000 rpm and 5000 rpm, respectively. The fatigue life results showed that the number of cycles of failure for the coated piston is approximately 12% and 31% higher than the original piston at engine speeds of 1000 rpm and 5000 rpm, respectively. To evaluate properly of results, stress analysis and fatigue life results is compared with experimental damaged piston and it has been shown that critical identified areas, match well with areas of failure in the experimental sample.

© 2023 IAU, Arak Branch. All rights reserved.

Keywords: Piston; Thermal barrier coating; Residual stress and fatigue life.

1 INTRODUCTION

IN the engine industry, the piston is the most important component subjected to high thermal and mechanical loads. In addition, gas pressure, piston acceleration and piston skirt side fore can develop thermo-mechanical stresses superposed on thermal stresses. Therefore, it must be designed to withstand thermo-mechanical stresses

*Corresponding author. Tel.: +98 912 7235677.
E-mail address: ashouri1394@gmail.com (H.Ashouri)

induced by the heat and pressure process [1,2]. The thermo-mechanical stresses and fatigue distribution enable us to optimize the piston design at a lower cost before the constructed of the prototype [1,3,4]. Thermal insulation of pistons is one of the ways to reduce thermo-mechanical stresses on the engine pistons. It can be achieved by a thermal barrier coating on the piston crown [5,6]. Thermal barrier coating (TBC) can also be applied on the inner surface of exhaust manifold, valves, combustion chamber and cylinder [6]. The main goal of TBC is to increase thermal efficiency. This coating system causes a reduction in heat losses, and therefore, the engine power and combustion temperature will be increased. Then, fuel compulsion and gas emissions are expected to be decreased [6,7]. TBC system have a ceramic coat top (TC) layer and also a metallic bond coat (BC) layer. The TC and BC layers are made of $MgZrO_3$ and $NiCrAl$, respectively [5]. There are many researches investigate in the field the simulation of fatigue and thermo-mechanical stresses on the piston. Evaluation of thermal barrier coating on stress and deformation distribution in gasoline engine piston was studied by Nouby et al. Increasing the coating thickness reduces the stress value [5]. Ashouri performed Fatigue life assessment for an aluminum alloy piston. The numerical results showed that the temperature maximum occurs at the piston crown center [3]. Improving high cycle fatigue (HCF) life in a gasoline engine piston using oil gallery with considering stress gradient was studied by Ashouri. The obtained thermo-mechanical analysis results proved that the oil gallery reduces the stress distribution in the piston about 7 MPa and 12 MPa at engine speed 1000 rpm and 5000 rpm respectively [4]. Prakash et al. investigated effect of TBC on engine piston to improve efficiency using dual fuel. At full load condition it concluded that the blend combination with thermal barrier coated piston brake thermal efficiency (BTE) and brake specific fuel consumption (BSFC) improved [8]. Thermal analysis of holes created on ceramic coating for diesel engine piston was the subject another study by Gehlot and Tripathi. Compared with coating have no hole, a significant increase in the pistons top surface temperature occurs with coating having holes [9]. Selvam et al. examined the effect of TBC on performance on an engine. Their experiments proved that hydrocarbon and carbon monoxide are some major pollutants tend to reduce in the coated piston than the uncoated piston [10]. Wear resistance mechanism of engine piston skirt coating under cold start condition was conducted by Xuguang et al. Their study showed that the TBC reduces the contact pressure in the piston by about 40% [11]. Ramaswamy et al., predict a model to the effect of inconsistencies in TBC thicknesses in pistons. From the simulation results it is inferred that that the temperature reduction in a 30 micron coated piston is 36.68 K [12]. Jian et al., investigated wear behavior of graphite coating on aluminum piston skirt of engine. The results showed the deposition of graphite coating plays an important role on decreasing friction and resisting the scuffing of cylinder bore [13]. Yao et al., evaluated enhanced high-temperature thermal fatigue property of aluminum alloy piston with nano thermal barrier coatings. Their study proved that the substrate temperature of Nano coated piston is considerably lower than that of the uncoated piston [14]. Yao and Li did thermal analysis of nano coated aluminum alloy piston. The results of their study disclosed that TBC decreases distribution of temperature in substrate of piston [15]. Numerical and experimental investigation of a piston thermal barrier coating for an automotive diesel engine application was performed by Caputo et al. The reduction of wall temperature 4.7% was reported in the coated piston [16]. Reghu et al., studied the effect of TBC on temperature distribution in engine piston. Their study disclosed that TBC decrease distribution of temperature in the substrate of piston [17]. Stress and fatigue analysis of engine pistons using thermo-mechanical model was carried out by Chen et al. The numerical results showed that piston bowl is critical region [2]. Liu et al., investigated Failure analysis and design improvements of steel piston for a high-power marine diesel engine. His research results showed that the excessive stress amplitude caused by the alternating gas pressure is the root cause of steel piston failure [1].

In the literature although there are a lot of numerical and experimental evaluations on TBCs in the piston, there is a lack of science in the field of studying stress and fatigue life in coated piston considering the residual stress. It is also important to predict the pistons temperature distribution in order to control the thermal stresses and fatigue life within acceptable level. Therefore, the goal of current study is to predict fatigue life for a coated piston considering residual stress. For this purpose, Solidworks software was used to model the piston. Then the thermo-mechanical analysis was carried out to get the temperature and stress distribution in ANSYS software. Finally, the thermo-mechanical results were fed into the ANSYS nCode Design Life software to investigate the fatigue life of the piston. The effect of engine speeds on thermo-mechanical stress and fatigue life of the piston is also investigated in this work.

2 THE FINITE ELEMENT MODEL AND MATERIAL PROPERTIES

FEA makes accurate and reliable assessment of thermo-mechanical stresses and fatigue life results in the engines

pistons. Finite element analysis allows engineers to find manifold weakness at the primary step or to detect the root reason of piston failures [3,4,18]. The characteristics of the engine under study are summarized in Table 1.

Table 1

Specification of the engine under study [19].

Parameter	Value
Bore (mm)	83
Stroke (mm)	81.4
Connecting rod (mm)	150.5
Engine volume (cc)	1761
Compression ratio	9.3
Max power (kW)	70.8@6000 rpm
Max torque (N-m)	153.4@2500 rpm
No. of valve	8

Due to the symmetrical structure of the piston, a 1/4 3D solid model was created. The piston analyzed in this article is shown in Fig. 1. Piston is made of AlSi alloy with a Young's modulus of 90 GPa, a Poisson's ratio of 0.3, and a coefficient of thermal expansion of 21×10^{-6} per °C. Piston is modeled with three-dimensional continuum elements. The model consists of 43571 elements (Tet10) for improving the accuracy and acceptability of the obtained results [3,4].

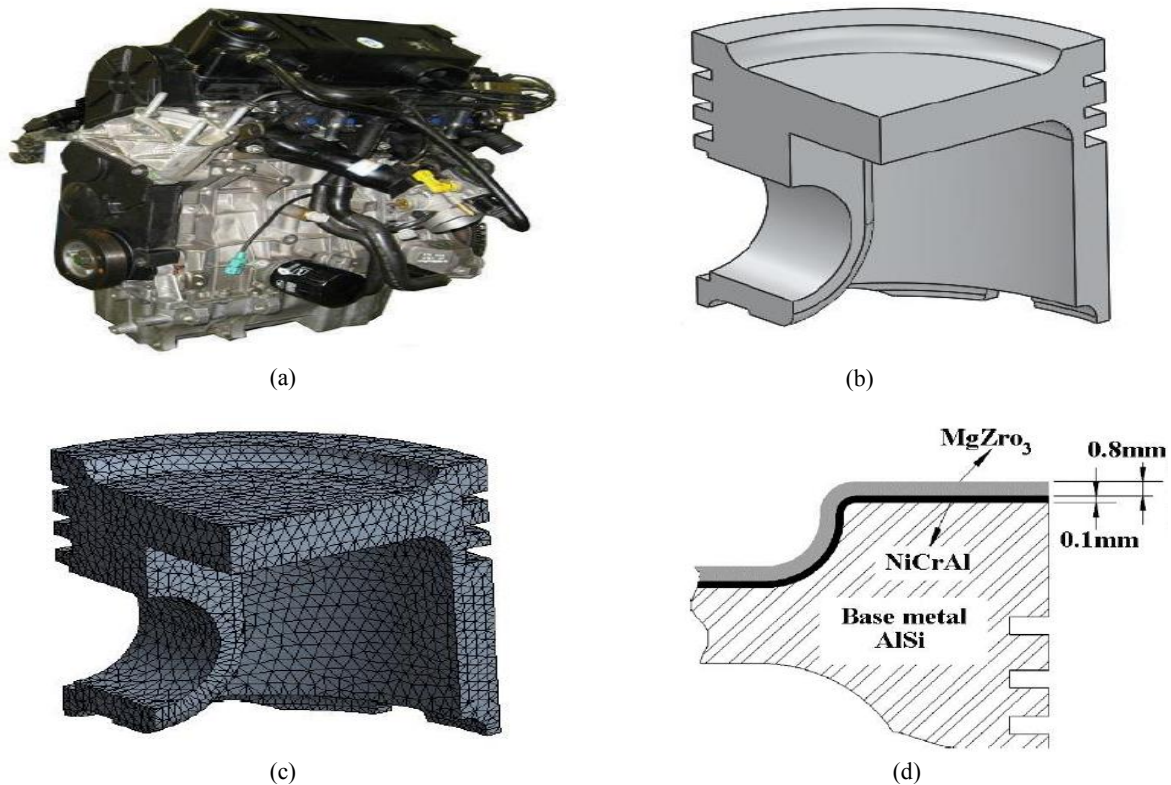

Fig.1

a) XU7JP/L3 gasoline engine, b) The piston generated by SolidWorks, c) Finite element model of the piston and d) TBC system.

The differential equation of time dependent heat flow is given in polar coordinate by [20]:

$$\frac{1}{r} \frac{\partial}{\partial r} \left(kr \frac{\partial}{\partial r} \right) + \frac{1}{r} \frac{\partial}{\partial \theta} \left(kr \frac{\partial}{\partial \theta} \right) + \frac{\partial}{\partial t} \left(k \frac{\partial}{\partial r} \right) = \frac{1}{\alpha} \left(\frac{\partial T}{\partial t} \right) \quad (1)$$

where k is the thermal conductivity, r is the radius distance and α thermal diffusivity. For the steady state thermal analysis of the piston, the major mechanism for heat transfer is convection. In this paper, the fluid temperature T_f and the convection coefficient h are considered as the boundary conditions of the problem. These conditions can be mathematically expressed as follows [20]:

$$-k \frac{\partial T}{\partial n} = h(T - T_f) \quad (2)$$

Based on engine dynamics, the reciprocating inertia force F_i is related to the acceleration of the piston. The force action line is parallel to the center of the cylinder. This force is calculated as [18]:

$$F_i = m_i R \omega^2 (1 + \lambda \cos 2\alpha) \quad (3)$$

The acceleration at the moment of combustion is given as [18]:

$$a = R \omega^2 (\cos \alpha + \lambda \cos 2\alpha) \quad (4)$$

where R represents the radius of crank, ω is the rotating speed of engine, and λ is the ratio of crank radius to the length of connecting rod [1,4]. If the engine is working, the piston does linear reciprocating movement along the cylinder. Since the piston skirt is in contact with the cylinder, it is subjected to a side thrust force due to the force of connecting rod. The solving formula of side thrust force is as follows [18]:

$$F_c = (F_{gas} - F_i) \tan \beta \quad (5)$$

where F_c is the side thrust force of the piston, F_{gas} is the gas explosion pressure of the piston crown and β is the angular displacement of connecting rod.

According to the thermal spraying process, which applies coating layers on the piston, a thermal cycle is applied on the finite element model before all loadings. The temperature of the TC layer is reduced sharply from 2680°C to room temperature during 12000 s. This cooling process leads to residual stress in the substrate and coating layers. Then fatigue analysis is performed on the coated piston according to quenching stress (σ_q) and the thermal stress (σ_t), as below [21]:

$$\sigma_q = \alpha_c E_c \Delta T \quad (6)$$

$$\sigma_t = (E_c / 1 - \nu_c) (\alpha_s - \alpha_c) \Delta T \quad (7)$$

where α_c is the thermal expansion coefficient of coating, E_c is the elastic modulus of coating, ν_c is the poisson's ratio of coating, α_s is the thermal expansion coefficient of the substrate and ΔT is the temperature difference. Therefore, the total residual stress is defined by relation [21]:

$$\sigma = \sigma_q + \sigma_t \quad (8)$$

The stress-based approach to fatigue is typically used for life prediction of components subject to high cycle fatigue, where stresses are mainly elastic. It uses the material stress-life curve and employs fatigue notch factors to account for stress concentrations, empirical modification factors for surface finish effects, and analytical equations such as Goodman equation to account for mean stress effects [22]:

$$\frac{\sigma_a}{S_e} + \frac{\sigma_m}{S_u} = 1 \quad (9)$$

where σ_a is alternating stress in the presence of mean stress, S_e is alternating stress for equivalent completely reversed loading, σ_m is mean stress and S_u is ultimate tensile strength.

3 RESULT AND DISCUSSION

3.1 Thermal analysis

Thermal stresses in the pistons are the dominant stresses, leading to fatigue in the pistons. As a result, thermal loading is the most critical loading in the thermo-mechanical fatigue analysis of pistons. It is also crucial to evaluate the piston temperature field to detect the thermal stresses and fatigue life within the allowable limit. Thus, the first step of fatigue analysis is a thermal analysis to evaluate the temperature field for the piston [1,3,4,20]. Piston thermal boundary conditions consist of the combustion side thermal boundary condition, upper ring land, lower ring land and skirt thermal boundary condition, underside thermal boundary condition, inside piston surface and piston pin thermal boundary condition [1,9,20]. In this way, the inner temperature was estimated to be 650°C with a convection coefficient of $800\text{ W/m}^2\text{K}$. The upper ring land temperature of the piston was specified as 300°C with a convection coefficient of $230\text{ W/m}^2\text{K}$. The lower ring land temperature of the piston is defined as 110°C with a convection coefficient of $200\text{ W/m}^2\text{K}$. The piston skirt, piston inside surface and piston pin temperatures are defined as 85°C with convection coefficient of $60\text{ W/m}^2\text{K}$ [20]. The resulting temperature distributions on the original piston are given in Fig. 2 at engine speeds of 1000 rpm and 5000 rpm , respectively. This Figure indicates that the temperature distribution of the piston surface tends to decrease from the center to the edge of the piston. This situation is valid for the spark ignition engines in actual working conditions. This result is similar to that obtained on a similar type of piston in an earlier study [3,4].

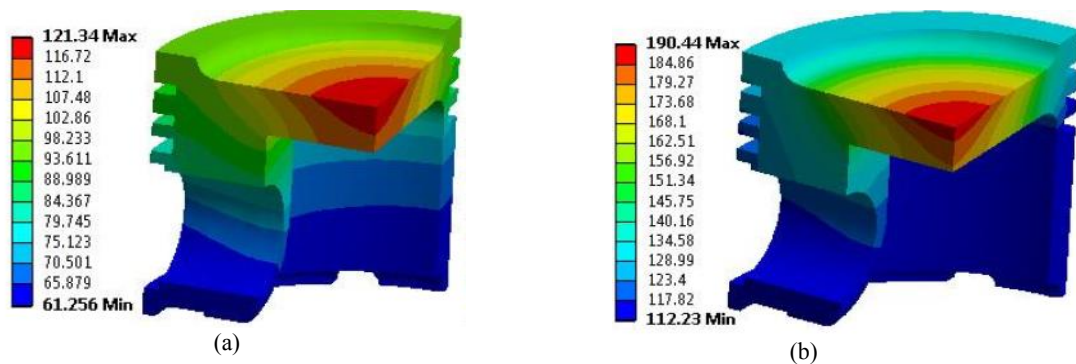

Fig.2

The temperature distribution in the original piston (a) at 1000 rpm and (b) 5000 rpm .

The resulting temperature distributions on the coated piston are shown in Fig. 3. As seen Fig. 3, the TBC system reduces the temperature distribution in the piston by about 8°C and 24°C at engine speeds of 1000 rpm and 5000 rpm , respectively. This can lead to lower stress values in the aluminum alloy substrate. Thus, the fatigue life of the pistons can be improved [20].

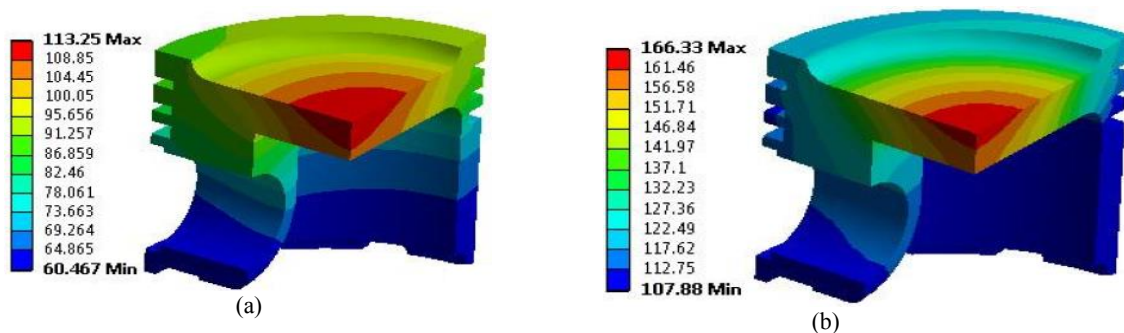

Fig.3

The temperature distribution in the coated piston (a) at 1000 rpm and (b) 5000 rpm .

3.2 Mechanical analysis

The piston bears the mechanical stress and withstands the thermal stress because of the temperature fluctuations. Therefore, the analysis of thermo-mechanical coupling stress on the piston is needed. The loads on the piston include gas pressure, reciprocating inertial force, side pressure, thermal load and support reaction on the inner surface of the pin hole [1,2,18]. Among them, the thermal load was the temperature field, which had been analyzed previously. The gas pressure was loaded on the piston top, combustion chamber surface, field of fire and ring grooves. The analysis of the thermo-mechanical coupling stress is based on the results of the mechanical stress analysis. The temperature distribution and the mechanical loads are taken into consideration at the same time. Import the calculated results of the piston temperature and impose the mechanical stress. Then finite element calculation is carried out and the results are studied. The Von-Mises stress distributions in the original piston are exhibited in Fig. 4.

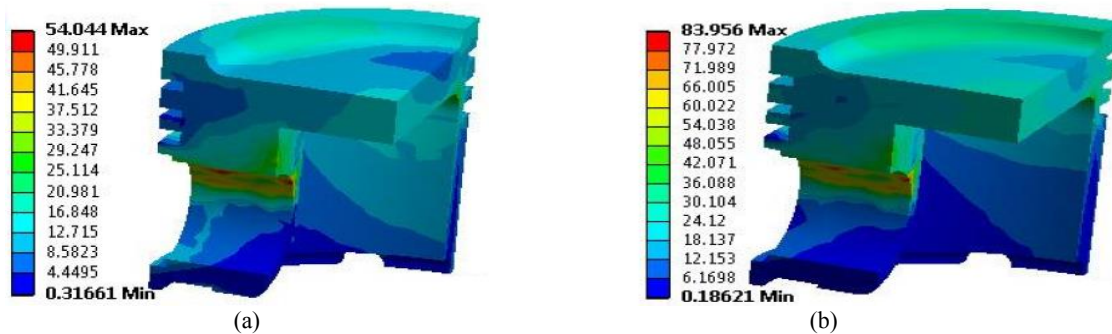

Fig.4
The Von-Mises stress distribution in the original piston (a) at 1000 rpm and (b) 5000 rpm.

Evaluation of the residual stress in the fatigue life for coated pistons is the main focus of this paper. Residual stress plays a key role in the fatigue life of coated components [21]. Von-Mises stress distributions are exhibited in Figs. 5 and 6 for the thermal spray process and thermal spray process plus thermo-mechanical loading, respectively. Fig. 5 shows that the result of residual stress is considerable. Thus, residual stress must be investigated in the thermo-mechanical analysis of the coated pistons. As can be seen from Figs. 4 and 6, TBC reduces the stress distribution in the piston by about 2.4 MPa and 8.5 MPa at engine speeds of 1000 rpm and 5000 rpm, respectively.

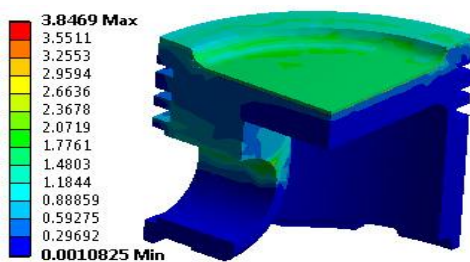

Fig.5
The Von-Mises stress distribution in the coated piston under thermal spray process (residual stress).

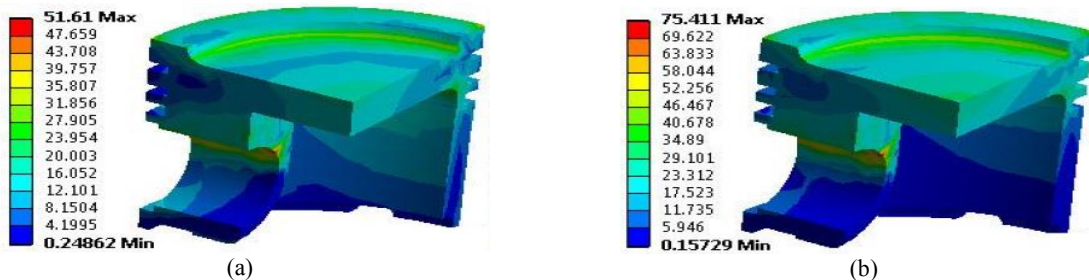

Fig.6
The Von-Mises stress distribution in the coated piston under thermal spray process (residual stress) plus thermo-mechanical loading (a) at 1000 rpm and (b) 5000 rpm.

3.3 HCF life prediction

From the thermo-mechanical analysis, it can be drawn that the maximum stress occurs at the upper portion of the piston pin, and fatigue failure would most likely occur in this region. As can be seen from Figs. 4 and 6, the maximum stress doesn't exceed the yield strength of the piston material which proved HCF for the piston. Therefore, it is necessary to perform the thermo-mechanical fatigue checkout for this piston [1,3,4]. For this purpose, fatigue tests are usually performed on the specific fatigue machine. However, they are complicated, expensive, and prolonged. In this paper, the HCF prediction, based on the Goodman equations, is conducted to calculate the fatigue life instead the experimental fatigue tests. The stresses histories were fed into the nCode Design Life software to investigate the fatigue life of the piston based on the HCF approach. Fig. 7 represents the number of cycles to failure based on Goodman criterion in the original piston. In Fig. 8 the fatigue life prediction in the coated piston is shown. As shown in failure contours, minimum HCF life occurs at the upper portion of piston pin. This corresponds to the results by [3,4]. The TBC system increases the fatigue life of the piston by about 12% and 31% at engine speeds of 1000 rpm and 5000 rpm, respectively.

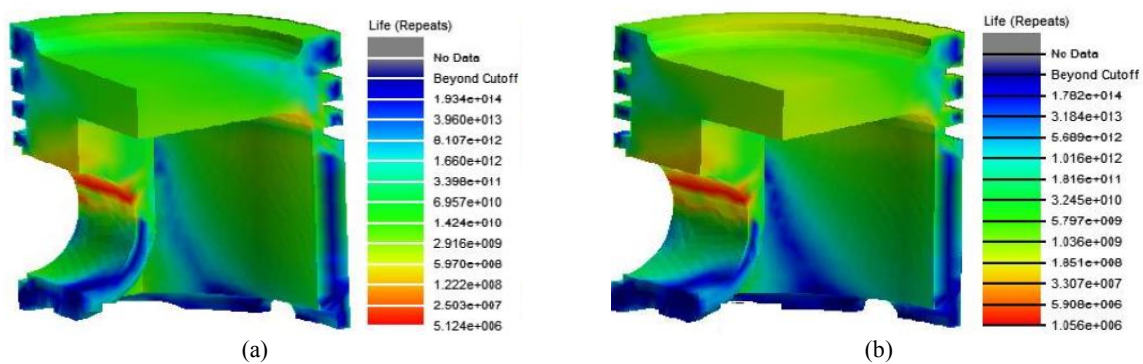

Fig.7

The number of cycles to failure in the original piston at (a) at 1000 rpm and (b) 5000 rpm.

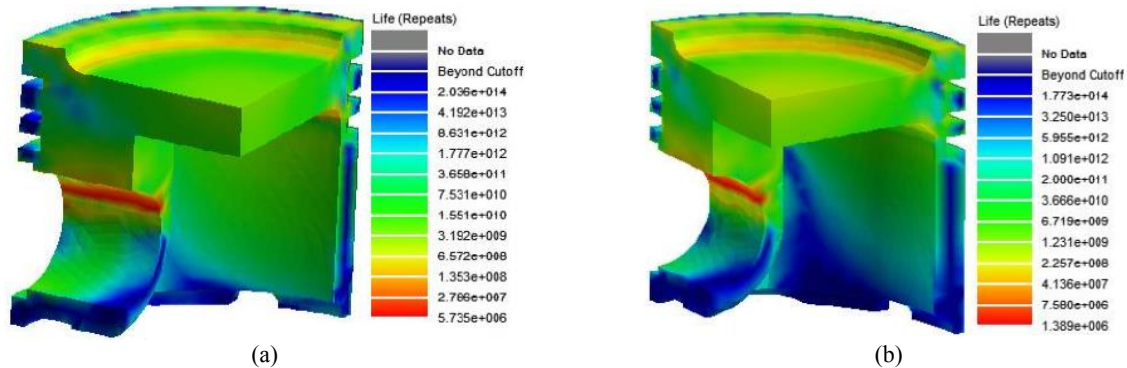

Fig.8

The number of cycles to failure in the coated piston at (a) at 1000 rpm and (b) 5000 rpm.

As can be seen from Figs. 4 to 8, due to the thermal and mechanical stresses, there are mainly two severe regions: the upper portion of the piston pin and piston compression grooves. Different engine pistons where cracks initiated in those areas will be presented subsequently. Thermo-mechanical stress analyses on the piston proved the same serious areas. Fig. 9(a) shows a piston which has been cracked in the region of upper portion of piston pin. Another typical fatigue damage occurs on piston compression grooves. Fig. 9(b) shows one damaged Piston in this area. A comparison of these Figures with Figs. 4 to 8 concludes that the fatigue life results have good agreement with the actual samples.



Fig.9
A damaged engine piston (a) in upper portion of piston pin and (b) on piston compression grooves [23].

4 CONCLUSION

The aim of this study is to study the effect of TBC system on the thermal stress and fatigue life in a gasoline engine piston with considering residual stress. The results of FEA demonstrated that the temperature distribution in the coated piston reduces by about 8°C and 24°C at engine speeds of 1000 rpm and 5000 rpm , respectively. Therefore, the piston endures less temperature and fatigue life will increase. The obtained thermo-mechanical analysis results proved that the TBC system reduces the stress distribution in the piston by about 2.4 MPa and 8.5 MPa at engine speeds of 1000 rpm and 5000 rpm , respectively. The fatigue life results showed that the number of cycles of failure for the coated piston is approximately 12% and 31% higher than the original piston at engine speeds of 1000 rpm and 5000 rpm , respectively. To evaluate properly of results, stress analysis and fatigue life results is compared with experimental damaged piston and it has been shown that critical identified areas, match well with areas of failure in the experimental sample. Computer aided engineering plays an important role to find the weakness of a piston layout at the early stage of the engine development

REFERENCES

- [1] Liu Y., Jing G., Liu H., Zhang W., Han M., Xiao S., Zhang Z., 2022, Failure analysis and design improvements of steel piston for a high-power marine diesel engine, *Engineering Failure Analysis* **142**: 106825.
- [2] Chen Z., Li J., Liao J., Shi F., 2019, Stress and fatigue analysis of engine pistons using thermo-mechanical model, *Journal of Mechanical Science and Technology* **33**(9): 4199-4207.
- [3] Ashouri H., 2022, Fatigue life assessment for an aluminum alloy piston using stress gradient approach described in the FKM method, *Journal of Solid Mechanics* **14**(1): 57-66.
- [4] Ashouri H., 2021, Improving high cycle fatigue life in a gasoline engine piston using oil gallery with considering stress gradient, *International Journal of Advanced Design and Manufacturing Technology* **14**(4): 73-82.
- [5] Nouby M., Ghazaly K., Abd El-Gwwad A., 2019, Evaluation of gasoline engine piston with various coating materials using finite element method, *International Journal of Automotive Engineering* **9**(2): 2942-2948.
- [6] Godiganur V.S., Nayaka S., Kumar G.N., 2020, Thermal barrier coating for diesel engine application—A review, *Journal of Materials Today: Proceedings* **45**: 133-137.
- [7] Balu P., Saravanan P., Jayaseelan V., 2020, Effect of ceramic coating on the performance, emission, and combustion characteristics of ethanol DI diesel engine, *Materials Today: Proceedings* **39**: 1259-1264.
- [8] Prakash S., Prabhakar M., Niyas O.P., Faris S., Vyshnav C., 2020, Thermal barrier coating on IC engine piston to improve efficiency using dual fuel, *Materials Today: Proceedings* **33**: 919-924.
- [9] Gehlot R., Tripathi B., 2016, Thermal analysis of holes created on ceramic coating for diesel engine piston, *Case Studies in Thermal Engineering* **8**: 291-299.
- [10] Selvam M., Shanmugan S., Palani S., 2018, Performance analysis of IC engine with ceramic-coated piston, *Environmental Science and Pollution Research* **25**: 35210-35220.
- [11] Xuguanga T., Jianb Z., Peiyu X., 2020, Wear resistance mechanism of engine piston skirt coating under cold start condition, *Engineering Failure Analysis* **118**: 104912.
- [12] Ramaswamy P., Shankar V.B., Reghu V.R.C., Mathew N., Manoj Kumar S.E., 2018, A model to predict the influence of inconsistencies in thermal barrier coating (TBC) thicknesses in pistons of IC engines, *Materials Today: Proceedings* **5**: 12623-12631.

- [13] Jiana Z., Zhong-yub P., Shi-yingc L., Sheng-weid S., Li-juna D., 2019, Investigation of wear behavior of graphite coating on aluminum piston skirt of automobile engine, *Engineering Failure Analysis* **97**: 408-415.
- [14] Yao Z., Hu K., Li R., 2019, Enhanced high-temperature thermal fatigue property of aluminum alloy piston with Nano PYSZ thermal barrier coatings, *Journal of Alloys and Compounds* **790**: 466-479.
- [15] Yao Z., Li W., 2019, Microstructure and thermal analysis of APS nano PYSZ coated aluminum alloy piston, *Journal of Alloys and Compounds* **812**: 152162.
- [16] Caputo S., Millo F., Boccardo G., Piano A., Cifali G., Concetto Pesce F., 2019, Numerical and experimental investigation of a piston thermal barrier coating for an automotive diesel engine application, *Applied Thermal Engineering* **162**: 114233.
- [17] Reghu V.R., Mathew N., Tilletic P., Shankar V.D., Ramaswamy P., 2020, Thermal barrier coating development on automobile piston material (Al-Si alloy), numerical analysis and validation, *Materials Today: Proceedings* **22**: 1274-1284.
- [18] Liu X.F., Wanga Y., Liuc W.H., 2017, Finite element analysis of thermo-mechanical conditions inside the piston of a diesel engine, *Journal of Applied Thermal Engineering* **119**: 312-318.
- [19] Mirmohammadi A., Kalthor A., 2017, Studying turbocharging effects on engine performance and emissions by various compression ratios, *American Journal of Energy Power Engineering* **4(6)**: 84-88.
- [20] Yao Z., Qian Z., 2018, Thermal analysis of nano ceramic coated piston used in natural gas engine, *Journal of Alloys and Compounds* **768**: 441-450.
- [21] Pang M., Zhang X., Liu Q., Fu Y., Liu G., Tan W., 2020, Effect of preheating temperature of the substrate on residual stress of Mo/8YSZ functionally gradient thermal barrier coatings prepared by plasma spraying, *Journal of Surface & Coatings Technology* **385**: 125377.
- [22] Stephens R., Fatemi A., Fuchs H., 2001, *Metal Fatigue in Engineering*, John Wiley.
- [23] Silva F.S., 2006, Fatigue on engine pistons – A compendium of case studies, *Journal of Engineering Failure Analysis* **13**: 480-492.