

# Reliability of the Rubber Tube of Automotive Hydraulic Braking System Under Fatigue Failures Considering Random Variation of Load and the Process of Aging of Material

O. Larin, K. Potopalskaya<sup>\*</sup>, R. Mygushchenko

*National Technical University, Kharkiv Polytechnic Institute, Kharkiv, Ukraine*

Received 3 March 2019; accepted 23 April 2019

## ABSTRACT

This paper presents the approach for the assessing of the operational reliability of a multi-layer thick-walled tube made of rubber with textile reinforcement. The analysis of the fatigue accumulation process is carried out within the framework of the concept of the continuum mechanics of damage. The mathematical model, which takes into account the accumulation of damages in case of a random spread of the strength characteristics of the material, as well as the process of stochastic aging for the elastomeric matrix of the composite and possible random variation of the workload has been developed. In this case, the aging process is modelled as a reduction of the endurance limit of the material. In this paper, the mean equivalent strains of the tube and their possible statistical variation in operation have been investigated on the basis of the finite element method. To solve the above problems, a submodeling method has been employed in this work. The probability of non-failure operation of the tube has been determined using the methods and models proposed. The influence of the rate of the aging process on the life-time of the tube has been estimated.

© 2019 IAU, Arak Branch. All rights reserved.

**Keywords :** Rubber pipe; Composite; Fatigue; Life-time.

## 1 INTRODUCTION

**M**ULTILAYER thick-walled elastomeric tubes with curvilinear geometry are widely used in different hydraulic systems in modern vehicles. A number of main causes of the failures of automotive hydraulic braking system can be found based on the statistical study of a durability of such system [1]. Such reasons as static overload, wear and fatigue under cyclic load [2–4] as well as the chemical/physical degradation [5,6] caused by aging and/or interaction with aggressive the environment are the common failures for separate parts of this system [7,8], including rubber-based elements [5,9–11]. From much research presented in the literature it is known that for various rubber hoses, taps and pipes the most common types of failures are those appearing on the surface [3] or

<sup>\*</sup>Corresponding author. Tel.: +38 057 707-68-79.  
E-mail address: [ks.potopalskaya@gmail.com](mailto:ks.potopalskaya@gmail.com) (K. Potopalskaya).

between the layers. The research has shown that in multi-layer hoses an inter-phase strength is relatively weak thus, under the loads the initial cracks occur inside it and it gradually grows up to an outer rubber layer, leading to a final break [12,13]. Summarizing the above data, it can be argued that the operation of the different rubber hoses and pipes is usually accompanied with the dynamic (cyclic) load that leads to the fatigue accumulation in material. The assessment of fatigue resistance for various materials is given much attention in the literature, including the problems of fatigue durability in rubber-like materials [12,14–17]. It should be noted that known experimental data on the number of cycles for failure depending on the deformed state parameters and indicate that there is always a significant statistical variation in the definition of physical constants [2,18,19]. Therefore, regarding the assessment of fatigue durability of real engineering designs with rubber elements (like a hydraulic hose) the availability of appropriate spread should be taken into account. Moreover, exploitation of designs with rubber materials is coupled with the degradation process occurrence which leads to material chemical and physical changes as a result of the external environment influence and is not related to the load. It can be called the aging. For rubber materials and their composites, the aging process are primarily due to the oxidation (diffusion of oxygen molecules from the environment into the internal structure of rubber). Appropriate processes significantly affect the behavior of the material in particular; decrease the strength characteristics within the period, which is comparable to the operational time to fatigue. The previous random scatter of experimental data has existed over time. In the modern scientific and technical literature there are quite a lot of studies aimed at studying the effect of aging on mechanical characteristics of rubber. Particular attention deserves works [20,21] which deals with experimental research on the analysis of the effect of aging on the change of the elastic modulus of rubber materials, the limit values of strains and stresses that determine the material's strength, as well as resistance to fatigue.

Thus, within assessing the hoses reliability the processes of aging and at the same time the accumulation of fatigue damage considering the presence of random scatter of fatigue resistance parameters of material should be taken into account. Furthermore, it is patently that the actual operation of design has random variation of a load that should be considered while assessing the reliability of structures in general and rubber hoses in particular. This paper describes the approach to the assessment of operational reliability of multilayer thick-walled pipe with curvilinear geometry, which is made of rubber material reinforced by textile cord and used in automotive hydraulic braking system.

This work deals with the problem of predicting the reliability of automotive hydraulic braking hose under fatigue failures considering random variation of load and the process of the material aging. In general, the estimation of reliability consists of three consecutive stages:

- The definition of the characteristics of deformed state of a design in operation;
- The formulation of failure criterion regarding the most probable cause of possible system failures;
- Reliability determination problem which consists of the failure probability, as a time function within calculating process.

The solution of this problem can be divided into three stages as it is shown on Fig. 1

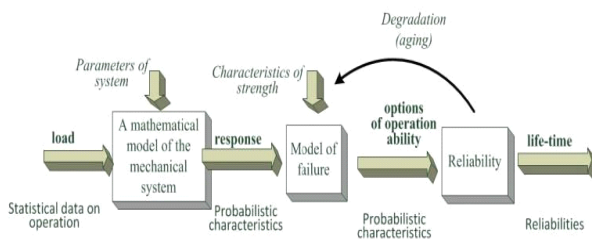

**Fig.1**  
Scheme for solving the reliability problem.

In this work the first stage of the problem mentioned, consisting of the system response determination on operational load has been solved within the finite element method (FEM). The problem has been solved in static nonlinear statement within a three-level sub-modeling technique. It allows to assess the concentration level of internal strains in the rubber matrix composite layer of the design. It should be noted that the actual operating conditions is related to the presence of random pulsations of pressure. In this work, it has been assumed that the stresses are qualitatively repeating the features of internal pressure pulsations, whose frequency is much lower than the first natural frequency of the design. On the second stage of this work has been proposed the mathematical model, with mentioned above characteristics of strain stress state that allows predicting random kinetics of continuum fatigue damage, which implicitly considers the simultaneous occurrence of the elastomeric material aging process. The degradation of properties has been designed as a process of the end limit reduction over the time.

The damage parameters have been introduced within the effective stress concept. In the final third stage, the problem of reliabilities determination of automotive hose consists of the identification of the probability characteristics of accumulative process of fatigue damage in the rubber tube, which is formed as a result of random amplitude variation around the quasi-static cyclic loading and which takes into account the simultaneous aging of rubber material.

## 2 FE-MODELING

The object of investigation is a sector of toroidal tube (Fig. 2), which has a multilayer structure that has been composed of three rubber layers. The average layer of tube is reinforced with textile cord. The geometric model has been created by the section extruding along the arc of given radius.

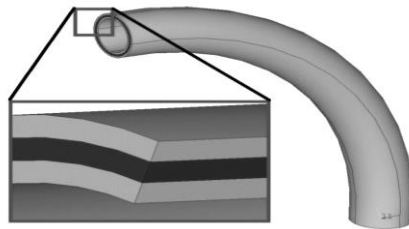

**Fig.2**  
Geometric model the breaking hose.

According to the FEA the rubber material in this design are therefore to reproduce a significant deformation under external load. The physical and geometric nonlinearity at the modeling is be taken into account. The deformed state analysis has been carried out within the finite element method. A regular hexagonal FE mesh with 3D solid elements with 8 nodes and 3-degrees of freedom in the node is used. The presence of the heterogeneity of the internal structure (cord) leads on the one hand to the orthotropy of the elastic properties, and on the other hand significantly complicates the stress state analysis since the corresponding heterogeneity caused the internal zones of stress concentration. It's almost impossible to take into account explicitly the presence of cords because it significantly increases the size of nonlinear problem that leads to the problems with convergence of numerical procedures for solution.

The sub-modeling method has been used in this work to solve the above mentioned problems. According to the approach the problem has been solved in several stages. On the first stage the calculation for the full model with a rather coarse mesh, which doesn't give accurate picture of the deformed state, but sufficient enough for the estimation of overall deformation (displacements) has been performed. On the second stage, from the full simulation model a certain part is allocated, which has more of dense mesh. The results of calculations of the displacement that have been received in the previous step of simulation are used as additional kinematic boundary conditions on the second stage. This allows to get more accurate results for stresses and strains for part of design without increasing the dimension of the full model. An additional third stage apart from the already diminished design has been used as a representational volume around the most loaded part. Within this model, cord elements have been built implicitly and it allows to assess the level of internal strain concentration in composite, which is formed by the heterogeneity of its structure. The finite-element model for all levels of sub-modeling is shown on Fig. 3.

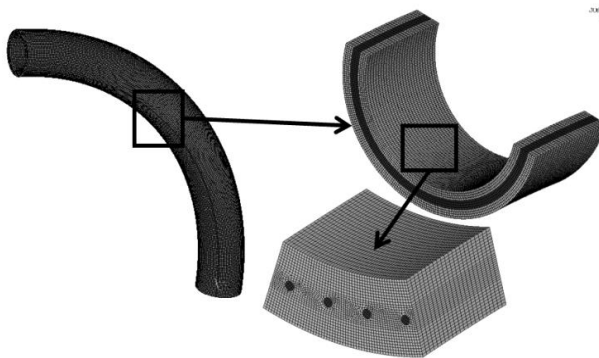

**Fig.3**  
Finite-element model for different levels of sub-modeling.

Hence, the first stage is considered as a full model: elbow of braking hose. The boundaries of the sector have been fixed. Uniformly distributed internal pressure has been applied as the load. The problem has been solved in nonlinear elastic formulation within the framework of large strains theory. The Rubber layers were considered in accordance with the neo-Hooke hyperelastic model. For the middle layer has been set the averaged orthotropic elastic properties according to generalized Hooke's law in toroidal coordinate system. The second stage of sub-modelling technique has been done with the same hypotheses considered just a part of the braking hose sector. The displacement that was identified during the previous modelling was imposed on border at rejected parts of the sector of rubber tube as additional boundary conditions.

The results of these calculations are shown in Fig. 4. The total displacement, which is calculated for the full model design, is shown in Fig. 4(a). An equivalent strain (Fig. 4(b)) has been determined based on the refined model of braking hose fragment. According to calculation, the maximum strain is concentrated in the inner layer of the braking hose and raises up to almost 16%. The maximum equivalent stress in the rubber layer is also observed in the inner layer and equals 0.6 MPa.

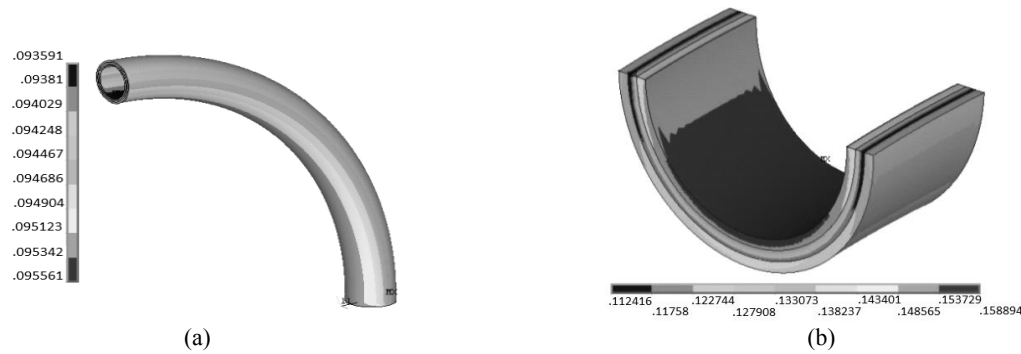

**Fig.4**  
FE modeling results. a) The total displacement b) Equivalent strains.

The presented in Fig. 4 deformed state does not include internal strain and stress concentrations in the composite. That has been assessed on another level of sub-modeling with explicit cord fibers consideration in the composite layer. The results of this study are shown in Fig. 5. It has also been determined that in the rubber matrix the level of equivalent strains due to internal localization of the elements of cord is 30%, which is in 2 times more than the maximum strains, which has been calculated during the previous study. The strains in fibers do not exceed 14%. The distribution of stresses is similar to the distribution of the strains: the maximum equivalent stress is in the rubber matrix and reaches 11 MPa, and 175 MPa in fibers.

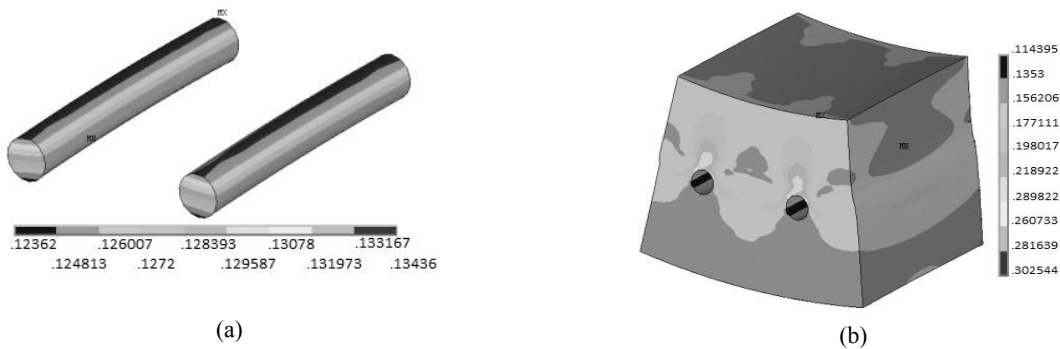

**Fig.5**  
Results of FE sub-modeling for the definition of strain in cords (a) and in the rubber matrix (b) of composite layer.

It should be emphasized that the actual operating conditions do not occur with a fixed load level, and there are always some variations admitted. Thus, in this paper we assume that deformed state has an average level that corresponds strains and stresses obtained from the calculations, but it also has a random pulsation around it with amplitude, which has a 30% coefficient of variation. The frequency of vibrations is constant (4 Hz). Thus it has been assumed that the stresses in the braking hose is stationary narrowband random process that satisfies Gaussian

distribution. This process will be determined with a fixed level of average stress  $\sigma_m$ , and random amplitude  $\sigma_a(t)$ , that changes according to the Rayleigh distribution and that has exponential correlation function.

### 2.1 The development of the probabilistic models kinetics of fatigue damage

The approach of continuum damage mechanics is used in this work. So, it is assumed that cyclic loading leads to accumulation of damage ( $D$ ) which is introduced within the framework of theory of Rabotnov-Kachanov. It is considered to be a normalized parameter which is limited by intervals:  $0 \leq D \leq 1$ .  $D(t)$  is considered to be isotropic and depends on the time  $t$ , stress amplitude  $\sigma_a$  and material parameters. Kinetic equation of damage accumulation is assumed to satisfy the traditional power form

$$\frac{d}{dt}D = B \left( \frac{\sigma_a(t)}{1-D} \right)^c \quad (1)$$

where  $B$  and  $c$  are constants of kinetic equation that should be determined experimentally and can be expressed through Wöhler curve characteristics.

For identification of constants  $B$  and  $c$  it is proposed to perform a simple test of fatigue load with fixed frequency and constant amplitude stress ( $\sigma_a = \text{Const}$ ).

In this case the life-time that can be determined by integration of Eq. (1) in conditions of constancy of parameters of the equation of simple test can be easily found ( $\sigma_a = \text{Const}$ ). So, at the moment of failure  $T_r$  the damage parameter is equal to unity and the time for failure can be found as follows:

$$T_r = \frac{1}{B(c+1)} \frac{1}{\sigma_a^c} \quad (2)$$

On the other hand, due to this simple fatigue test, the life-time is easily determined directly from the Wöhler Eq. (2).

$$N = \left( \frac{\sigma_a}{\sigma_e} \right)^m N_0 \quad (3)$$

where  $N$  is the number of loading cycles before failure at stress with amplitude  $\sigma_a$ ,  $m$  - parameter characterizing the slope of the Wöhler curve,  $\sigma_e$  - endurance limit,  $N_0$  - number of cycles for failure when the stress amplitude corresponds to the endurance limit  $\sigma_e$ . Time to failure in this simple test of fatigue (with fixed parameters of cycle) is determined by multiplying the number of cycles to failure for a period of one cycle of  $T_{sc}$ .

$$T_r = NT_{sc} = \frac{N}{\omega} = \frac{\sigma_e^m N_0}{\omega} \frac{1}{\sigma_a^m} \quad (4)$$

Thus, with accounting (2) and (4), the equation for the growth kinetics of fatigue damage (1) has the following form

$$\frac{dD}{dt} = \frac{\omega_e}{N_0(m+1)} \left( \frac{\sigma_a(t)}{\sigma_e} \right)^m \quad (5)$$

As it has been noted in the work introduction, that life-time of designed rubber elements is comparable to the time of aging the material. The natural aging related with degradation characteristics of the material [15,16,22]. The results of investigation of the patterns of the elastic properties changes, characteristics of static and fatigue strength

for various rubber materials due to the aging are shown in [22]. The results obtained show the presence of a significant effect of aging on the characteristics of fatigue strength.

For the description of patterns of change of fatigue strength characteristics in literature [2] it is often proposed to use hyperbolic dependence. Similarly, in this work we assume that the aging leads to a gradual decrease of the number of cycles for failure as follows:

$$N_0 = \frac{N_{00}}{(1 + \gamma \cdot t)} \tag{6}$$

where  $N_{00}$ ,  $\gamma$  – independent parameters that represent the initial value of the number of cycles to failure and its rate of change. From the data from experimental test it's known that fatigue strength characteristics have a significant random variation in their values, particularly on the number of cycles to failure. This work considers the accumulation of fatigue damage in a probabilistic statement. For this, the basic number of cycles to failure  $N_0$  assumes to be as a random variable that satisfies a normal Gaussian distribution with mean  $\langle N_0 \rangle$  and coefficient of variation  $Vn_0 = 0,1$ . According to this representation of the number of cycles to fracture can vary within 30% of the mean value. Certainly, existing scatter of the experimental data of the properties of the material fatigue resistance remains during aging. The most natural way to take this into account is the introduction of the assumption that the rate parameter of degradation in approximation (6) is also a random variable that is independent to  $N_0$ . It is assumed that this parameter is normal and provides data on current levels of their coefficients of variation in the range of 10%. Thus, the proposed Eq.(5) considers  $N_0$  as a function of time (6) with random parameters:

$$\frac{dD}{dt} = \frac{\omega_e}{N_0(t) \cdot (m+1) \cdot \sigma_e^m} \left( \frac{\sigma_a}{1-D} \right)^m = \frac{\omega_e \cdot (1 + \gamma \cdot t)}{N_{00} (m+1) \sigma_e^m} \left( \frac{\sigma_a}{1-D} \right)^m \tag{7}$$

As a part of this work the equation of accumulation of damage is presented in a probabilistic statement in which the stress amplitude is considered as a stationary random function with exponential correlation. The corresponding random component of stress amplitudes proposes to set used normalized random coefficients as follows:

$$N_{00} = \langle N_0 \rangle \chi \text{ and } \sigma_a(t) = \langle \sigma_a \rangle \cdot \xi(t) \tag{8}$$

where  $\langle N_0 \rangle$  – the mean value of initial value of a base number of cycles to failure,  $\chi$  – random parameter that describes the possible random variation from the mean value  $\langle N_0 \rangle$ , and similarly for the stress amplitude  $\langle \sigma_a \rangle$  – average value, and  $\xi$  – random parameter that describes the possible random variation from the mean value  $\langle \sigma_a \rangle$ . Then Eq. (7) in the new notation is

$$\frac{dD}{dt} = \psi \frac{\xi(t)^m}{(1-D)^m} \frac{\chi^{-1}(1 + \gamma t)}{(m+1)} \tag{9}$$

where  $\psi = \frac{\langle \sigma_a \rangle^m \omega_e}{\sigma_e^m \langle N_0 \rangle}$ .

The model described in this work will be used to study fatigue of automotive hydraulic braking hose. The appropriate model takes into account the existence of stationary narrowband random variation of stress with known parameters and process of degradation of characteristics fatigue resistance due to aging of the material. In the work it is assumed that the aging process and stress changes are statistically uncorrelated random functions of time. Therefore, the aging process does not affect the amplitude of the stress directly and vice versa. It is considered that stress is completely determined only by operation conditions of the design throughout the lifetime. On the other hand, in this paper the natural aging is described as a standalone process of physical and chemical changes in the material that are not caused by mechanical stress, which leads to the accumulation only of the fatigue damage. Furthermore, it should be noted that these processes have different time scales. The presented kinetic Eq. (9) describes the fatigue accumulation at the weak point in the design. As a result of the presence of random parameters  $\xi$ ,  $\chi$  and  $\gamma$  damage parameter will also be a random process. The statistical characteristics determination of damage

parameters (mean value, standard deviation and probability density function) that satisfies the Eq. (9) is the solution of the problem. The problem of damage is complicated by the non-linearity of differential Eq. (9). Consider a new function  $z(t)$ , which is determined by damage as follows:

$$z(t) = 1 - [1 - D(t)]^{m+1} \quad (10)$$

The derivative of this function is determined directly

$$\frac{dz(t)}{dt} = (m+1)(1-D)^m \frac{dD}{dt} \quad (11)$$

The substitution of (10) and (11) to (9) gives the differential equation relatively to the new function  $z(t)$ :

$$\frac{dz}{dt} = \psi \cdot \xi^m(t) \chi^{-1} (1 + \gamma t) \quad (12)$$

This equation is linear to relatively function  $z(t)$  and it is therefore very easily determined in quadrature

$$z(t) = \int_0^t \psi \xi^m(t_1) \chi^{-1} (1 + \gamma t_1) dt_1 \quad (13)$$

The resulting expression allows to use direct procedure of averaging for determination  $z(t)$  the function of mean value:

$$\langle z(t) \rangle = \left\langle \int_0^t \psi \xi^m(t) \chi^{-1} (1 + \gamma t) dt \right\rangle \quad (14)$$

$$\langle z \rangle = \psi \langle \xi^m \rangle \langle \chi^{-1} \rangle \left( t + \frac{\langle \gamma \rangle t^2}{2} \right) = k_1 t + k_2 t^2 \quad (15)$$

In expression (15) it is supposed that the random components of the amplitudes of stresses are stationary random processes according to the assumptions that it's a mean value and  $m$ -th statistical moments is a constant  $\langle \xi^m \rangle = Const$ . Let's introduce the following notation for the coefficients:

$$k_1 = \psi \cdot k_0 \langle \chi^{-1} \rangle, \quad k_2 = k_1 \frac{\langle \gamma \rangle}{2} \quad (16)$$

$k_0$  is a coefficient that is equal to  $m$ -th the initial statistical moment of random component of stationary pulsation of stresses amplitude:

$$k_0 = \langle \xi^m \rangle = \int_0^\infty \xi^m \cdot f_\xi(\xi) d\xi \quad (17)$$

Within the framework of the introduced assumptions, the random component of stress over time of braking hose in considered as fixed narrowband normal process, and then the probability density function of amplitudes of this process satisfying Rayleigh law

$$f_\xi(\xi) = \frac{\xi}{\sigma_\xi^2} \exp\left(-\frac{\xi^2}{2\sigma_\xi^2}\right) \quad (18)$$

Substituting (18) in (17) we obtain an expression for the coefficient  $k_0$ :

$$k_0 = \int_0^\infty \xi^m \cdot f_\xi(\xi) d\xi = \int_0^\infty \frac{\xi^{m+1}}{\sigma_\xi^2} \exp\left(-\frac{\xi^2}{2\sigma_\xi^2}\right) d\xi = \sigma_\xi^m 2^{\frac{m}{2}} \Gamma\left(\frac{m}{2} + 1\right). \tag{19}$$

where  $\Gamma(x)$  is the gamma function, defined by the integral

$$\Gamma(x) = \int_0^\infty y^{x-1} e^{-y} dy \tag{20}$$

By the usage of averaging one can find the variance of the process, which corresponds to the correlation function concurring moment of time  $t_1=t_2=t$ .

$$\sigma_z^2 = K_z(t_1=t, t_2=t) \tag{21}$$

Correlation function of the process  $z(t)$  is the second centered statistical moment that is taken into account (15) and takes the form by its definition:

$$K_z = \langle z(t_1) \cdot z(t_2) \rangle - \langle z(t_1) \rangle \cdot \langle z(t_2) \rangle = \langle z(t_1) \cdot z(t_2) \rangle - k_1 \left(1 + \frac{\langle \gamma \rangle}{2} t_1\right) \left(1 + \frac{\langle \gamma \rangle}{2} t_2\right) t_1 t_2 \tag{22}$$

The first component in (22) is a second initial statistical moment that requires a determination. For its definition in the first phase one can find the integral representation for the function  $z(t)$ , (13). Thus, the following expression can be obtained:

$$\begin{aligned} \langle z(t_1) \cdot z(t_2) \rangle &= \psi^2 \int_0^{t_1} \int_0^{t_2} \langle \xi^m(t_1) \cdot \xi^m(t_2) \chi^{-2} (1 + \gamma t_1)(1 + \gamma t_2) \rangle dt_1 dt_2 = \\ &= \psi^2 \int_0^{t_1} \int_0^{t_2} \langle \xi^m(t_1) \cdot \xi^m(t_2) \rangle \langle \chi^{-2} \rangle \left[ 1 + \gamma(t_1 + t_2) + \gamma^2 t_1 t_2 \right] dt_1 dt_2 = \\ &= \psi^2 \langle \chi^{-2} \rangle \left[ \int_0^{t_1} \int_0^{t_2} \langle \xi^m(t_1) \xi^m(t_2) \rangle dt_1 dt_2 + \langle \gamma \rangle \int_0^{t_1} \int_0^{t_2} \langle \xi^m(t_1) \xi^m(t_2) \rangle (t_1 + t_2) dt_1 dt_2 + \langle \gamma^2 \rangle \int_0^{t_1} \int_0^{t_2} \langle \xi^m(t_1) \xi^m(t_2) \rangle t_1 t_2 dt_1 dt_2 \right] \end{aligned} \tag{23}$$

Hence, three integrals should be found to determine the initial moment of the function  $z(t)$

$$\langle z(t_1) \cdot z(t_2) \rangle = \psi^2 \langle \chi^{-2} \rangle \left( I_0 + \langle \gamma \rangle \cdot I_1 + \langle \gamma^2 \rangle \cdot I_2 \right) \tag{24}$$

First of all, the integrand expression should be found  $\langle \xi^m(t_1) \cdot \xi^m(t_2) \rangle$  in the first integral (it should also be noted that the multiplier of this expression is present in all three integrals). For conciseness lets enter the designation  $\xi_1 = \xi(t_1)$  and  $\xi_2 = \xi(t_2)$ . So, an expression in the first integral in (24), (25) is a correlation of random part amplitudes of stresses in the power  $m$  and according to the definition the correlation moment it has the following form:

$$\langle \xi_1^m \xi_2^m \rangle = \int_0^\infty \int_0^\infty \xi_1^m \xi_2^m \cdot f_{\xi\xi}(\xi_1, \xi_2, \tau) d\xi_1 d\xi_2 \tag{25}$$

where  $f_{\xi\xi}(\xi_1, \xi_2, \tau)$  - two-dimensional probability density function of the random component of amplitudes of stresses as a stationary process, and  $\tau = (t_2 - t_1)$  is the difference of points in time for the correlation, that the period of time of autocorrelation process which should define a time dependence in two-dimensional probability density functions and correlation stationary process. It's taken into account that the characteristics of stationary processes do not depend on the timing by definition but depend on only from period of correlation, i.e. two-dimensional characteristics do not depend on specific values of time  $t_1$  and/or  $t_2$ , just on their difference  $\tau$ . In this work the



random component of stress over time considering as fixed narrowband normal process, two-dimensional probability density function of this process satisfies the Rayleigh law:

$$f_{\xi\xi}(\xi_1, \xi_2, \tau) = f_{\xi}(\xi_1) f_{\xi}(\xi_2) \left[ 1 + R(\tau) \cdot \left( 1 - \frac{\xi_1^2}{2\sigma_{\xi}^2} \right) \left( 1 - \frac{\xi_2^2}{2\sigma_{\xi}^2} \right) \right] \quad (26)$$

where  $R(\tau)$  – normalized correlation function of the random component of the stress amplitude of braking hose. This function is exponential due to assumptions:

$$R(\tau) = e^{-\alpha|\tau|} \quad (27)$$

where  $\alpha$  – defined as the inverse value of the correlation time of stationary random process of stresses pulsation in this work:

Therefore, substituting (26) and (27) to (25) we obtain the following expression:

$$\begin{aligned} \langle \xi_1^m \cdot \xi_2^m \rangle &= \int_0^{\infty} \int_0^{\infty} \xi_1^m \xi_2^m \cdot f_{\xi}(\xi_1) f_{\xi}(\xi_2) d\xi_1 d\xi_2 + \int_0^{\infty} \int_0^{\infty} \xi_1^m \xi_2^m \cdot f_{\xi}(\xi_1) f_{\xi}(\xi_2) \cdot R(\tau) \cdot \left( 1 - \frac{\xi_1^2}{2\sigma_{\xi}^2} \right) \left( 1 - \frac{\xi_2^2}{2\sigma_{\xi}^2} \right) d\xi_1 d\xi_2 = \\ & \left[ \int_0^{\infty} \xi_1^m \cdot f_{\xi}(\xi_1) d\xi_1 \right]^2 + \left[ \int_0^{\infty} \xi_1^m \cdot f_{\xi}(\xi_1) \cdot \left( 1 - \frac{\xi_1^2}{2\sigma_{\xi}^2} \right) d\xi_1 \right]^2 \cdot R(\tau) \end{aligned} \quad (28)$$

So, the correlation of random components of changes of amplitudes of stress in power  $m$  is a linear expression with the respect to its normal correlation function:

$$\langle \xi_1^m \cdot \xi_2^m \rangle = k_0^2 + k_3^2 R(\tau) \quad (29)$$

where the coefficient  $k_0$  is given by (19) and  $k_3$  – depend through gamma function, as follows:

$$k_3 = \int_0^{\infty} \xi_1^m \cdot f_{\xi}(\xi_1) \left( 1 - \frac{\xi_1^2}{2\sigma_{\xi}^2} \right) d\xi_1 = \sigma_{\xi}^m 2^{\frac{m}{2}} \left[ \Gamma\left(\frac{m}{2} + 1\right) - \Gamma\left(\frac{m}{2} + 2\right) \right] \quad (30)$$

The corresponding integrals can be found quite easily by taking integral parts, but they are given in fairly cumbersome expressions. At the same time, it is enough in this work for further calculations to determine the variance of the process  $z(t)$ . The mentioned variance is found like a correlation function, in matching time points (22). Thus integrals  $I_0$ ,  $I_1$  and  $I_2$ , can be only determined at the substitution of

$$t_1 = t_2 = t \quad (31)$$

Substituting (29) in the expression for the integral  $I_0$ ,  $I_1$  and  $I_2$ , according to (24) and (27), and taking into account (31) we get:

$$\begin{aligned} I_0|_{t_1=t_2=t} &= \int_0^t \int_0^t \langle \xi_1^m \xi_2^m \rangle dt_1 dt_2 = \int_0^t \int_0^t k_0^2 + k_3^2 R(\tau) dt_1 dt_2 = \int_0^t \int_0^t k_0^2 + k_3^2 e^{-\alpha|t_2-t_1|} dt_1 dt_2 \\ I_0|_{t_1=t_2=t} &= \frac{2k_3^2}{\alpha^2} \left( e^{-\alpha t} + \frac{k_0^2}{2k_3^2} \alpha^2 t^2 + \alpha t - 1 \right) \end{aligned} \quad (32)$$

Similarly, for next integrals:

$$I_1|_{t_1=t_2=t} = \int_0^t \int_0^t \langle \xi_1^m \xi_2^m \rangle (t_1 + t_2) dt_1 dt_2 = \int_0^t \int_0^t (k_0^2 + k_3^2 R(\tau))(t_1 + t_2) dt_1 dt_2$$

$$I_1|_{t_1=t_2=t} = \frac{2k_3^2}{\alpha^2} \left( te^{-\alpha t} + \frac{k_0^2}{2k_3^2} \alpha^2 t^3 + \alpha t^2 - t \right) \tag{33}$$

$$I_2|_{t_1=t_2=t} = \int_0^t \int_0^t \langle \xi_1^m \xi_2^m \rangle t_1 t_2 dt_1 dt_2 = \int_0^t \int_0^t (k_0^2 + k_3^2 R(\tau)) t_1 t_2 dt_1 dt_2$$

$$I_2|_{t_1=t_2=t} = \frac{2k_3^2}{\alpha^4} \left( 1 - e^{-\alpha t} - \alpha t e^{-\alpha t} - \frac{1}{2} \alpha^2 t^2 + \frac{k_0^2}{8k_3^2} \alpha^4 t^4 \right) \tag{34}$$

Expressions (32)-(34) can be further simplified, taking into account, actual operation time of automotive hydraulic braking hose. It is measured in years (in the formula (32)-(34) it is given in seconds). Considering this, the definition of damage's variance and consequently the function  $z(t)$  is interesting for values which are measured exactly in years, then in the expressions (32)-(34) it can be neglected the terms  $I$ ,  $e^{-t}$  and  $te^{-t}$  have small applications compared to other members.

Thus, the expression (32)-(34) will be as follows:

$$I_0|_{t_1=t_2=t} = k_0^2 t^2 + \frac{2k_3^2}{\alpha} t \tag{35}$$

$$I_1|_{t_1=t_2=t} = k_0^2 t^3 + \frac{2k_3^2}{\alpha} t^2 - \frac{2k_3^2}{\alpha^2} t \tag{36}$$

$$I_2|_{t_1=t_2=t} = \frac{k_0^2}{4} t^4 - \frac{k_3^2}{\alpha^2} t^2 \tag{37}$$

According to (21) and (24) and found integrals (35)-(37) variance of process  $z(t)$  are defined as polynomial of the 4th order:

$$\sigma_z^2 = K_z(t_1=t, t_2=t) = \psi^2 \langle \chi^{-2} \rangle (I_0|_{t_1=t_2=t} + \langle \gamma \rangle I_1|_{t_1=t_2=t} + \langle \gamma^2 \rangle I_2|_{t_1=t_2=t})$$

$$\sigma_z^2 = \beta_4 t^4 + \beta_3 t^3 + \beta_2 t^2 + \beta_1 t \tag{38}$$

where the coefficients  $\beta_i$  are constant parameters that are defined by the following way:

$$\beta_4 = \psi^2 \langle \chi^{-2} \rangle \langle \gamma^2 \rangle \frac{k_0^2}{4} \tag{39}$$

$$\beta_3 = \psi^2 \langle \chi^{-2} \rangle \langle \gamma \rangle k_0^2 \tag{40}$$

$$\beta_2 = \psi^2 \langle \chi^{-2} \rangle \left( k_0^2 + \frac{2k_3^2}{\alpha} \langle \gamma \rangle - \frac{k_3^2}{\alpha^2} \langle \gamma^2 \rangle \right) \tag{41}$$

$$\beta_1 = \psi^2 \langle \chi^{-2} \rangle \frac{2k_3^2}{\alpha} \left( 1 - \frac{\langle \gamma \rangle}{\alpha} \right) \tag{42}$$

Therefore, the analytical expressions for one-dimensional stochastic characteristics of stationary random process  $z(t)$ : mean value  $\langle z \rangle$  and variance  $\sigma_z^2$  have been obtained. The resulting characteristics are polynomials of time

according to the expressions (16) and (37) with coefficients  $k_i$  and  $\beta_i$ , which can be calculated by formulas (16), (19) and (38)-(42). It should be noted that in the expressions for the coefficients  $k_i$  and  $\beta_i$  it is presented factors  $\langle \chi^{-1} \rangle$  and  $\langle \chi^{-2} \rangle$  which should be separately determined in accordance with the rules of averaging of random variables, i.e.:

$$\langle \chi^{-1} \rangle = \int_0^{\infty} \chi^{-1} \cdot f_{\chi}(\chi) d\chi = \int_0^{\infty} \chi^{-1} \cdot \frac{1}{\sqrt{2\pi}V_{N0}} \exp\left[-\frac{(\chi-1)^2}{2 \cdot V_{N0}^2}\right] d\chi \tag{43}$$

$$\langle \chi^{-2} \rangle = \int_0^{\infty} \chi^{-2} \cdot f_{\chi}(\chi) d\chi = \int_0^{\infty} \chi^{-2} \cdot \frac{1}{\sqrt{2\pi}V_{N0}} \exp\left[-\frac{(\chi-1)^2}{2 \cdot V_{N0}^2}\right] d\chi \tag{44}$$

### 3 RELIABILITY ANALYSIS

Expression (47) allows to analyze the fatigue damage accumulation patterns considering the material degradation and also makes it possible to calculate the reliability of breaking hose in operation. The key point of this approach is to determine the probability of automotive hydraulic hose failure, based on time or to determine the probability density function of the life-time.

The probability of reliability (often called reliability function) can be defined as the probability of double inequality regarding damage parameter, i.e. the probability that the damage parameter must be positive value and be less than one [13].

$$P(t) = \Pr[D \in (0,1)] = \int_0^1 f_D(D,t) dD = 1 - Q(t) \tag{45}$$

where  $P(t)$  - is the reliability function,  $Q(t)$  - probability of reverse event, i.e. the probability of failure. In formulas  $\Pr[\dots]$  is marked as the operator for calculating of probabilities of event.

The diagram that explains the meaning of the formula (51) is shown on Fig. 6.

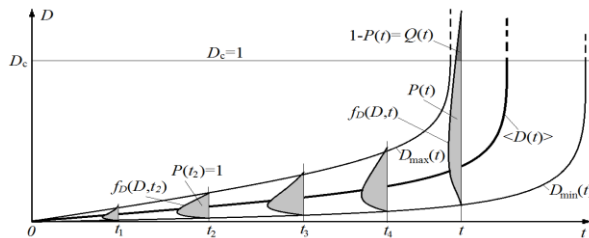

**Fig.6** Schematic explanations for calculating the probability of failure and reliabilities due to the growth of damage parameter.

The probability density of life-time  $q(t)$  can be calculated with a failure probability  $Q(t)$ , as a derivative over a time. The mean lifetime  $\langle T_r \rangle$  and its variance ( $\text{Var}[T_r]$ ) with a density of probability life-time is determined by the known formulas:

$$q(t) = \frac{d}{dt} Q(t) = -\frac{d}{dt} P(t) \tag{46}$$

$$\langle T_r \rangle = \int_0^{\infty} t q(t) dt, \quad \text{Var}[T_r] = \int_0^{\infty} (t - \langle T_r \rangle)^2 q(t) dt \tag{47}$$

Based on the known probability density function of the process  $z(t)$  can be determined; the damage probability density function of  $D(t)$  using the functional relationship between these processes (10) once can be found [23]:

$$f_D(D,t) = f_z\left(z = \left[1 - (1-D)^{m+1}\right], t\right) \cdot \left| \frac{\partial z}{\partial D} \right|, \quad f_D(D,t) = \frac{(m+1)(1-D)^m}{\sqrt{2\pi} \cdot \sigma_z(t)} \exp\left[-\frac{\left(1 - \langle z(t) \rangle - (1-D)^{m+1}\right)^2}{\sigma_z^2(t)}\right] \quad (48)$$

The additive function  $z(t)$  is given. Formally it can be represented as the sum of random variables (such representation can be obtained by rewriting of Eq. (12) through the integrated sum), the referring to the central limit theorem of probability theory, it can be used the hypothesis that this function must satisfy a normal Gaussian distribution (at least be close to it, especially for time values which are close to failure, because in this case, in the integral sum the number of members is large enough). Therefore, one-dimensional probability density function of non-stationary random process  $z(t)$  can be represented by the following expression:

$$f_z(z,t) = \frac{1}{\sqrt{2\pi}\sigma_z(t)} \exp\left[-\frac{\left(z - \langle z(t) \rangle\right)^2}{2\sigma_z^2(t)}\right] \quad (49)$$

Expression (46) makes it possible to calculate the mean process of accumulation of damage  $\langle D \rangle$ , and also a confidence interval  $\Omega_D$  of possible variations of this process with a specified probability  $\gamma$  (in the  $\gamma = 0,9995$ ).

$$\langle D(t) \rangle = \int_0^\infty D \cdot f_D(D,t) dD \quad (50)$$

$$\Pr[D \in \Omega_D = (D_{\min}, D_{\max})] = \gamma \quad (51)$$

$$D_{\max} : \frac{\gamma}{2} = \int_0^{D_{\max}} f_D(D,t) dD, \quad D_{\min} : \gamma = \int_{D_{\min}}^{D_{\max}} f_D(D,t) dD \quad (52)$$

According to formulas (52) limits of the confidence interval are calculated iteratively for each value of time  $t$ . At first the upper limit has been determined by the series of calculations of first integrals in (52) until the value reached half the value of confidence. The next step was a similar procedure to determine the lower limit.

The results of reliability design parameters calculations are shown on Fig. 7. The probability of breaking hose failure, as a function of time, and dotted curve is average damage (Fig. 7(a)). In this paper, it was analyzed the influence of parameter  $\gamma$ , which characterizes the rate of aging. The parameter is varied in a broad range of values from 0 to 32 year<sup>-1</sup>. A value of zero corresponds to assessment of fatigue without the aging process, while if  $\gamma$  should be 32 year<sup>-1</sup>, it means that the number of cycles to failure at a fixed level of strain decreases on order (10 times) for 3 months. Existing experimental data about rubber, which is close by its material properties [24]) showed that  $\gamma$  should be 2 year<sup>-1</sup> (for 4 years the number of cycles to failure declining in order). The life-time of automotive hydraulic braking system in this case is 6.5 years and an average is almost 10 years. The dependence of change of characteristics of the life-time (guaranteed, average and maximum possible) on the parameter  $\gamma$  are shown in Fig. 7.

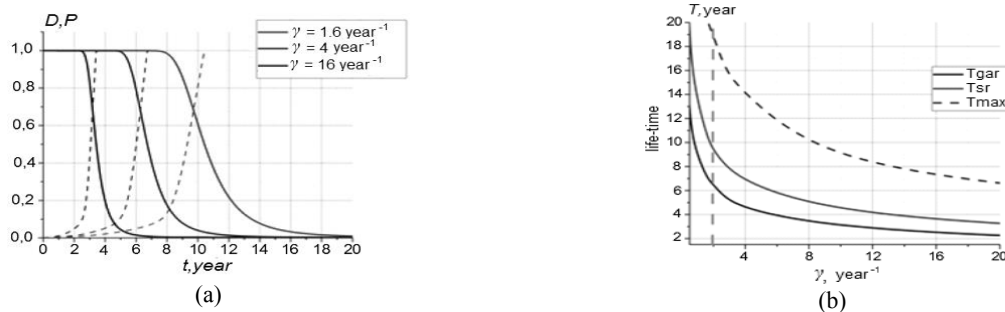

**Fig.7** Reliabilities and life-time (a) of automotive hydraulic braking system depending on the rate of aging of the material and dependencies of change the characteristics of the life-time (b).

From statistical data, failures in the flexible components of the automotive hydraulic braking system [1] that are caused by fatigue can occur at every 8000 km of travelling in one in every 1,000 cars. It is also known from the statistical research that a passenger car makes stop per km from 0.9/km to 3.68/km depending on level of traffic [25]. From that data it can be calculated that one of automotive hydraulic braking system can failures after 3500 cycles. Also in work [12] has been shown that failure rubber hose can occur from 42,000 cycles. It means that on failure of automotive hydraulic braking system should be taken into account the influence not only the physical changes, but also availability of random load and aging process. After the calculations, which were made in that work, it can be concluded that in one of every 100 automotive hydraulic braking system will be a failure after 2 years of operation.

#### 4 CONCLUSIONS

The work deals with mathematical modeling of reliability multilayer rubber-cord braking hose. The method of assessment of the accumulation of fatigue damage in this design has been proposed, which takes into account the possible variation of stresses during operation, and processes of change in fatigue resistance characteristics in materials as a result of aging. Characteristics of deformed state of the braking hose have been analyzed within the finite element method using the iterative procedure of sub-modeling. It is determined that as a result of the internal concentration, the level of strain reaches up to 30% around the cord elements, which has been caused by the heterogeneity of the composite structure. Considering the random process of aging, and allowing the random variation of the stress around the mean, the probability of failure value has been calculated and life-time of the braking hose has been forecast. The influence of aging rate parameter on the statistical characteristic of material life-time has been analyzed.

#### REFERENCES

- [1] Renu R., Visotsky D., Knackstedt S., Mocko G., Summers J.D., Schulte J., 2016, A knowledge based FMEA to support identification and management of vehicle flexible component issues, *Procedia CIRP* **44**: 157-162.
- [2] Moon S., Cho I., Woo C., Kim W., 2011, Study on determination of durability analysis process and fatigue damage parameter for rubber component, *Journal of Mechanical Science and Technology* **25**: 1159.
- [3] Cho J.R., Yoon Y.H., Seo C.W., Kim Y.G., 2015, Fatigue life assessment of fabric braided composite rubber hose in complicated large deformation cyclic motion, *Finite Elements in Analysis and Design* **100**: 65-76.
- [4] Cho J-R., Yoon Y-H., 2016, Large deformation analysis of anisotropic rubber hose along cyclic path by homogenization and path interpolation methods, *Journal of Mechanical Science and Technology* **30**: 789-795.
- [5] Budinski M.K., 2013, Failure analysis of a rubber hose in anhydrous ammonia service, *Case Studies in Engineering Failure Analysis* **1**: 156-164.
- [6] Chandran D., Ng H.K., Lau H.L.N., Gan S., Choo Y.M., 2016, Investigation of the effects of palm biodiesel dissolved oxygen and conductivity on metal corrosion and elastomer degradation under novel immersion method, *Applied Thermal Engineering* **104**: 294-308.
- [7] Pierce S.O., Evans J.L., 2012, Failure analysis of a metal bellows flexible hose subjected to multiple pressure cycles, *Engineering Failure Analysis* **22**: 11-20.
- [8] Reza Kashyzadeh K., Farrahi G.H., Shariyat M., Ahmadian M.T., 2018, Experimental accuracy assessment of various high-cycle fatigue criteria for a critical component with a complicated geometry and multi-input random non-proportional 3D stress components, *Engineering Failure Analysis* **90**: 534-553.
- [9] Krismer S., 2003, Hydraulic hose failures caused by corrosion of the reinforcing strands, *Practical Failure Analysis* **3**: 33-39.
- [10] Pavloušková Z., Klakurková L., Man O., Čelko L., Švejcar J., 2015, Assessment of the cause of cracking of hydraulic hose clamps, *Engineering Failure Analysis* **56**: 14-19.
- [11] Noda N.-A., Yoshimura S., Kawahara H., Tuyunaru S., 2008, FEM Analysis for Sealing Performance of Hydraulic Brake Hose Crimped Portion and Its Life Estimation, *Transactions of the Japan Society of Mechanical Engineers Series A* **74(748)**: 1538-1543.
- [12] Kwak S., Choi N., 2009, Micro-damage formation of a rubber hose assembly for automotive hydraulic brakes under a durability test, *Engineering Failure Analysis* **16**: 1262-1269.
- [13] Mars W.V., Fatemi A., 2002, A literature survey on fatigue analysis approaches for rubber, *International Journal of Fatigue* **24(9)**: 949-961.
- [14] Fedorko G., Molnar V., Dovica M., Toth T., Fabianova J., 2015, Failure analysis of irreversible changes in the construction of the damaged rubber hoses, *Engineering Failure Analysis* **58**: 31-43.
- [15] Hansaka M., Ito M., 1999, Investigation on aging of train rubber hose, *Quarterly Report of RTRI* **40(2)**:105-111.

- [16] Haseeb A.S.M.A., Jun T.S, Fazal M.A., Masjuki H.H., 2011, Degradation of physical properties of different elastomers upon exposure to palm biodiesel, *Energy* **36**(3): 1814-1819.
- [17] Lee G., Kim H., Park J., Jin H., Lee Y., Kim J., 2011, An experimental study and finite element analysis for finding leakage path in high pressure hose assembly, *International Journal of Precision Engineering and Manufacturing* **12**: 537-542.
- [18] Larin O.O., 2015, Probabilistic model of fatigue damage accumulation in rubberlike materials, *Strength of Materials* **47**(6): 849-858.
- [19] Larin O., Vodka O., 2015, A probability approach to the estimation of the process of accumulation of the high-cycle fatigue damage considering the natural aging of a material, *International Journal of Damage Mechanics* **24**(2): 294-310.
- [20] Wei Y., Nasdala L., Rothert H., Xie Z., 2004, Experimental investigations on the dynamic mechanical properties of aged rubbers, *Polymer Testing* **23**: 447-453.
- [21] Huang D., LaCount B.J., Castro J.M., Ignatz-Hoover F., 2001, Development of a service-simulating, accelerated aging test method for exterior tire rubber compounds i. cyclic aging, *Polymer Degradation and Stability* **74**(2): 353-362.
- [22] Coronado M., Montero G., Valdez B., Stoytcheva M., Eliezer A., García C., Campbell H., Pérez A., 2014, Degradation of nitrile rubber fuel hose by biodiesel use, *Energy* **68**: 364-369.
- [23] Larin O.O., Vodka O.O., Trubayev O.I., 2014, The fatigue life-time propagation of the connection elements of long-term operated hydro turbines considering material degradation, *PNRPU Mechanics Bulletin* **1**(1):167-193.
- [24] Bellander M., Gedde U.W., 2016, Degradation of carbon-black- filled acrylonitrile butadiene rubber in alternative fuels, Transesterified and hydrotreated vegetable oils, *Polymer Degradation and Stability* **123**: 69-79.
- [25] Barlow T.J., Latham S., McCrae I.S., Boulter P.G., *A Reference Book of Driving Cycles for Use in the Measurement of Road Vehicle Emissions*, Published Project Report PPR354.