

Evaluation of Damage Problems in the Water Pump Components of an Air Compressor Cooling System: a Case Study

Moslem Tayebi¹, Hesam Moghadasi², Davood Rahmatabadi², Enayatollah Mohemi³,
Ramin Hashemi^{2*}

¹School of Materials Science, Sahand University of Technology, Tabriz, Iran

²School of Mechanical Engineering, Iran University of Science and Technology (IUST), Narmak, 16846-13114, Tehran, Iran

³National Iranian South Oil Company, Technical Inspection and Corrosion Metals Laboratory

*Email of Corresponding Author: rhashemi@iust.ac.ir

Received: July 9, 2016; Accepted: September 10, 2016

Abstract

In this paper, the reasons of damage water pumps parts of the air compressor cooling system were studied. To reach this goal, the works like preparing metallographic samples, evaluation of structure, investigation of mechanical properties, the alloy parts detection and chemical analysis of deposit and corrosion products collected from the parts were performed. According to studies and results obtained, alloys suggested to be used in the impeller and casing are gray cast iron with flake graphite (random distributed) and ductile iron with spherical graphite (distributed almost uniformly), respectively. Also cause damage to the pump impeller, graphitic corrosion was described.

Keywords

Impeller, Casing, Graphitic Corrosion, Gray Cast Iron, Air Compressor Cooling System

1. Introduction

In general, a pump refers to a device that transfers mechanical energy from an external source to the passing fluid. Pumps are used in various industries such as mining, petroleum, automotive, construction and marine. Among different types of pumps, the centrifugal pumps are very important because of their usage. Minimizing the pump failures is so important and one of main tools to study these failures is reliability[1]. The main reasons for focusing on reliability of the pumps are as follows [2, 3]:

1. Average cost of maintenance and operation of centrifugal pumps is 50 percent higher than other rotating equipment.
2. Centrifugal pumps of most industrial units consume more than 50 percent of their motor power.
3. Pumps need more energy than other industrial equipment. The average efficiency of pumps may be less than 40 percent and sometimes less than 10 percent.

In 2006, the causes of corrosion and fracture of pumps which inject seawater into the oil wells were investigated; the result of this research shows that employment of polymer material of salt water of offshore platforms would extend the life cycle and improve the efficiency of those pumps. Also employment of polymer composite coatings on the metal blades of pumps and on their casing would improve the pumps cavitations and erosion damage resistance.

In 2010, the corrosion of centrifugal pumps at Saba Steel Complex has been studied and the results showed that the cause of the problem is cavitations. To resolve this problem, solutions such as replacement of the alloy and employment of coatings were suggested [3-5].

This paper studies the damage causes of the centrifugal water pump parts of cooling system of air compressor of pressure amplification unit. The pump impeller and its casing are respectively made of the gray iron and ductile iron with an almost uniform distribution of spherical graphite in it. The type of impeller damage is described as Graphite corrosion. This type of corrosion is categorized as selective corrosion. A solution for preventing corrosions such as graphite corrosion is replacement of the alloy. Employment of white cast iron greatly reduces the risk of happening of such phenomenon.

1.1 centrifugal pumps

Centrifugal pump is a rotary machine in which the flow and pressure are dynamically generated, which is called "pumping". Because of the many changes that happen in velocity of fluid when it crosses impeller and passages, this type of pumps is also called Roto-dynamic pumps[2].

Centrifugal pumps are made of rotary components including shaft and impeller and fixed components including casing, stuffing box and bearing. Other parts like shaft sleeve and casing wear ring are added for a better performance. In Fig.1 a cutaway view of a centrifugal pump and its components is shown [2].

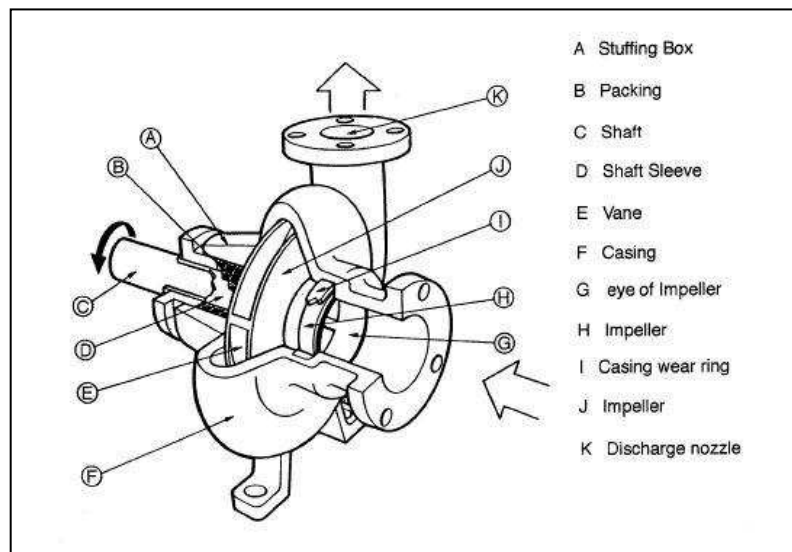

Figure1. A cutaway view of a centrifugal pump and its components

1.1.1 Introduction to some components of Centrifugal Pumps

Casing: The set of rotating blades of a centrifugal pump is inside a sealed housing called "Casing", which the volute of the pump is a part of it [2].

Impeller: Impellers convert mechanical rotation to velocity. Impellers are usually produced using casting or welding methods. Small impellers for clean water pumping are made of bronze or brass. On the other hand, large impellers are usually made of cast iron ASTM A-48-40 [3].

2.1.1 Damage Causes of centrifugal pumps

Because of the working condition of the water pumps of cooling systems, in general the main damage causes of their impellers are corrosion and cavitation, the other issues such as chemical corrosiveness of fluid or electrochemical effects usually play a lesser role in the destruction of impellers and pumps.

Cast iron is widely used in the casing of centrifugal pumps. Cast iron is used when the fluid pH is lower than 6. In this case, cast iron plays a protective coating role on the surface of metal. This coating protects the graphite coating of the surface of metal from corrosion. High viscosity fluids, cavitations, metal-metal contact and erosion could affect the protective coating [4].

2. Laboratory Studies

With creating multiple metallographic samples from intact and adjacent areas of corroded parts of the casing and impeller, the structural condition and beginning and extension of the damage were investigated. Also, the Brinell hardness method was conducted on the samples. Sediment and corrosion products on the damaged pump impeller were collected and were chemically decomposed.

3. Discussion and Conclusion

Examination of metallographic samples of the casing and impeller of the pump showed that the alloy used in impeller, gray cast iron which its approximate equivalent is ASTM A 278 (Table. 1) has a hardness of 111 HB and the alloy used in the casing, ductile iron which is approximately equivalent to ASTM A536 [5] (Table. 2) has a hardness of 156 HB. In the standards mentioned above, different classifications are based on a minimum tensile strength. Due to dimension limits of the impeller, providing a tensile sample determining the exact classification was not possible. However this doesn't affect the final evaluation.

Table1. Chemical composition of pump impeller

Element	Percent
C	3.60
Mn	0.55
P	0.52
S	0.175
Si	3.44
Cr	0.08
Ni	0.03
Mo	0.01
Fe	Base

Table2. Chemical composition of pump casing

Element	Percent
C	3.59
Mn	0.06
P	0.04
S	0.027
Si	2.95
Cr	0.006
Ni	0.02
Mo	0.003
Fe	Base

Examination of microstructure of metallographic samples showed that the pump casing has a uniform distribution of spherical graphite (Figure 2) and the pump impeller has a random distribution of graphite sheets in the field of ferrite – pearlite.(Figure 3, 4)

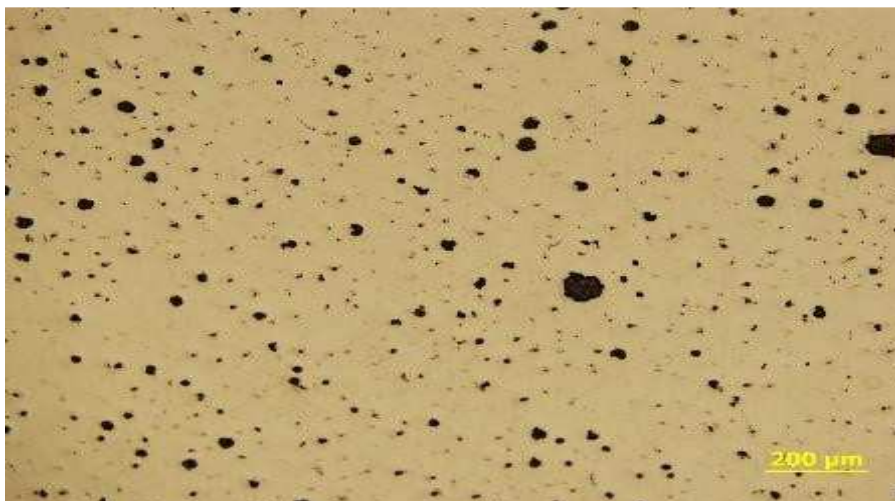

Figure2. Spherical graphite with almost uniform distribution of the sample metallographic taken from the pump body

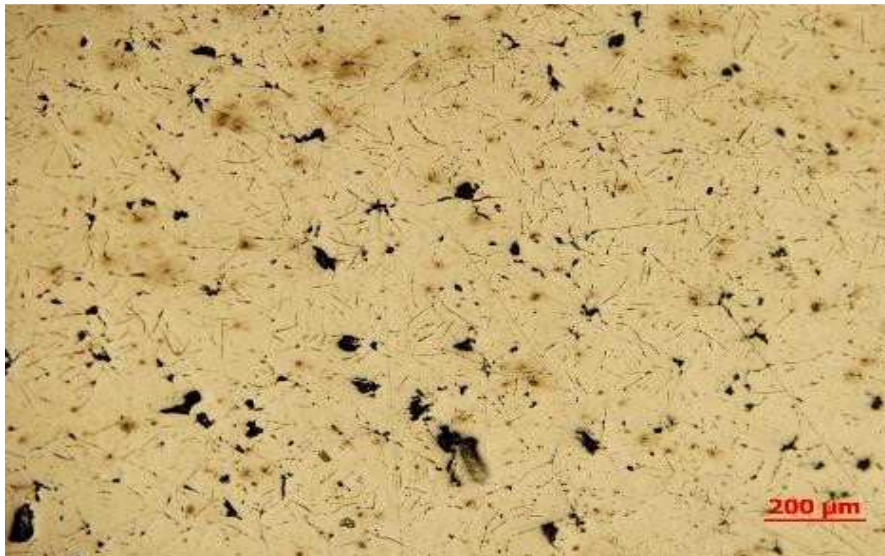

Figure3. Graphite of sheets representing grey cast iron used in the polished sample pump impeller



Figure4. Graphite sheets in sample ferrite-perlite structure taken from the pump impeller (affectation picral affectation)

In some parts of the microstructure, porosity of the casting process also is observed to a limited extent. Severe corrosion along with thickness reduction is evident in some of the interior components of the pump.

In addition to reducing the thickness, sediment accumulation and corrosion products on the components are visible as shown in Figure. 5.



Figure5. Damage and the formation of deposits on the inner cover of the pump

The damaged pump impeller is coated by black, brittle, fragile, and quite porous deposition. (Figure6)



Figure6. Corrosion and destruction of water pump impeller of the cooling system air compressor

Due to the fact that cooling system alloy tubes are made of stainless steel, therefor corrosion in the pipes has to be seen significantly. Most fractures are gathering at the junction of the plain carbon where steel coating is used as shown in Figure 7.



Figure7. Corrosion at the junction of cooling water system to the compressor

With gathering multiple metallographic samples from different parts of the pump impeller in particular the surrounding area of damage and thickness reduction, structural condition and possible changes were evaluated.

As shown in Figure.8, the collapse of the graphite cast iron grids and formation of black and porous layer and also formation of corrosion products that in some areas include up to half of the thickness of the sample is evident.



Figure8. Separation of cast iron from iron and leaving the black graphite layers on the surfaces of the pump impeller, when polishing the sample

By focusing on the corrosion areas and enlarging in microscopic examination, exacerbated corrosion in the contact Ferrite- pearlite and graphite-free complex network of rail network Graphite or iron sulfide remain detectable impurities. In metallographic samples taken from the

Evaluation of Damage Problems in the Water Pump Components of an Air Compressor Cooling System: a..., pp. 13-21
pump body, signs of reduced thickness were also seen. But there is far less sediment accumulation or corrosion products.



Figure9. Iron-free areas because of graphite corrosion

At the surfaces of the pump impeller, the intensification of corrosion at the contact point of the graphite with the ferrite – perlite network is discernable marked places.

Water quality analysis in air compressors of cooling water system represents significant amounts of chlorine ions. The footprint of this element in sediments collected from inner pump and surfaces of the impeller are detectable.

4. Results

According to studies, particularly considering the results of structural evaluation and chemical decomposing of the sediment, the type of impeller damage is graphite corrosion. Graphite corrosion is categorized as selective corrosion.

Considering the fact that the pump casing is made of ductile cast iron, and this type of cast iron is resistant against graphite corrosion, still the signs of damage on the pump casing and even other components of the air compressor of cooling system are evident, so, it seems that the general condition of the fluid is suitable for the occurrence of electro-chemical corrosion and thus in some parts, other types of corrosion such as water corrosion are appeared.

Graphite corrosion has been reported mostly in case of cast iron parts, particularly the internal components of pumps, pipes and fittings in contact with water, soil or acidic electrolytes. Obviously increase of anions and cations in the fluid, specially the hydrogen and chlorine ions, will increase the reaction rate and lead to further corrosion, in this condition, the presence of chloride ion in the water cooling system is evaluated important and effective.

The sediment collected from the inside of the pump casing and the surface of impeller was chemically decomposed. The main compounds of the sediment were iron oxide, graphite carbon, sulfur and silica. The considerable amount of chlorine ion is also noteworthy.

The graphics in the gray cast iron compared with iron nets are less inclined to reaction. If the cast iron is in electrolyte, grid iron usually reacts in oxide or sulfide form (depending on the conditions of the fluid) and then is removed and leaves an iron-free and graphite-saturated network.

In summary, in this phenomenon, a sort of galvanic corrosion occurs on a microscopic scale between the constituents of the alloy in the electrolyte. Graphite sheets or aggregated residual as a black and brittle layer on the surface will be recognizable. Thickness reduction in this type of corrosion appears to be insignificant and often decrease in mechanical properties, particularly tensile strength and alloy yielding is important.

5. Recommendations

The presence of corrosive factors such as chlorine ions in water used in the air compressor of the cooling system in which chemical analysis of the sediment and corrosion products also uncovers the role of these factors can be considered. It seems that in this regard, focusing more on quality of used water and adapting its characteristics to the conditions in manufacturer's instructions will be necessary.

A solution that is often used to prevent corrosions such as graphite corrosion is proposed to replace the alloy. It is essential that the phenomena and damages such as selective separation occur due to specific metallurgical structure of some alloys. Therefore, by changing the conditions of this type of alloy, such damages will reduce probably. For example, replacing gray cast iron with other white cast iron reduces the risk of this phenomenon strongly. However, in terms of reducing, it is discussed with regard to significant corrosion in other system components. It is very important to conduct these strategies more carefully.

The white cast iron is very hard machining alloy and if this alloy be used, the cost of pump gets high. In general, white cast iron is used when erosion is important. But, when the corrosion is important, the alloy such as stainless steel is usually used (such as AISI 410, 420).

References

- [1] Reidy, R. 2012. Profile of the International Pump Industry, Market Prospects to 2006, Sixth Edition, Elsevier.
- [2] Avallone, U. A., Baumeister, H. and Sadegh, L. 2007. Marks' Standard Handbook for Mechanical Engineers, Mechanics of Solids. 11th Edition, McGraw-Hill Education
- [3] Karassik, I. J., Messina, J. P., Cooper, P., Heald, C. C., Krutzsch, W., Hosangadi, A. et al. 1986. Pump handbook, McGraw-Hill New York.
- [4] Bachus, L. and Custodio, A. 2003. Know and Understand Centrifugal Pumps. Elsevier.
- [5] Reihani, A., Ojaghi, A., Derakhshan, S. Beigzadeh, B. 2014. Shaft Fatigue Life and Efficiency Improvement of a Micro Cross Flow Turbine, Engineering Solid Mechanics. 2 (1): 1-14.