

# The Impact of Corporate Social Responsibility on Innovative Performance by Considering the Mediating Role of Marketing Effectiveness A Case Study of Khuzestan Steel Industries



Journal of Industrial Strategic  
Management  
Year, 2022,  
Volume 7 (Issue 1),  
Pages: 22 - 28.

*Hamed Charkhab<sup>a</sup>, Ghanbar Amirnejad<sup>\*b</sup>*

*a Master Student Department of Business Management, Ahvaz Branch, Islamic Azad University, Ahvaz, Iran.  
b Associated Professor, Department of Management, South Tehran Branch, Islamic Azad University, Tehran, Iran.*

*Article history:  
Received: 24/04/2022  
Received in revised: 25/05/2022  
Accepted: 31/05/2022*

## **Abstract**

The present study aims to investigate the impact of corporate social responsibility on innovative performance by considering the mediating role of marketing effectiveness in Khuzestan Steel Industries. This study is applied in terms of the aim, descriptive-survey in terms of the approach and causal in terms of the type of research. The statistical population of the study includes all employees of Khuzestan Steel Industries. By using a convenience random sampling method, 306 statistical samples are included in the study. Data collection is done through a standard 26-item questionnaire. By this questionnaire, the answers are designed on a 5-point Likert scale- from strongly disagree to strongly agree. The validity of the questionnaire will be evaluated by face validity and confirmatory factor analysis, and its reliability by calculating Cronbach's alpha coefficient. After distributing and collecting questionnaires and extracting data, descriptive and inferential analyses are performed in SPSS and LISREL Software. In this process, analyses such as Cronbach's alpha coefficient calculation, descriptive statistics on research variables, KMO test, Kolmogorov-Smirnov test, confirmatory factor analysis and path analysis are used. Finally, the results indicate that corporate social responsibility has a positive and significant impact on innovative performance and marketing effectiveness variable plays a mediating role in this regard.

**Keywords:** Corporate Social Responsibility, Innovative Performance, Marketing Effectiveness, Khuzestan Steel Corporate

## **1. Introduction**

As the competition increases among corporates in the business environment, innovation plays a key role in the survival of corporates, as competition allows them to continually improve their competitive advantage (Pisano, 2015).

Due to limited resources, the corporate's innovation has increasingly relies on the participation and cooperation of customers, governments and other foreign stakeholders. Thus, it is essential for corporates to engage the interests of their external stakeholders. Recently, corporate social responsibility, as a common concern of external stakeholders, has been increasingly recognized as one of the ways to integrate the various interests of its external stakeholders (Steurer et al., 2005).

However, corporates may have to expand their costs to improve environmental management and performance,

which reduces these investments to innovations. Thus, it is not clear whether the corporate's innovation has grown by the beginning of corporate social responsibility activities. Studies suggest that corporate social responsibility can reduce the corporate's environmental risk and cost (Cai et al., 2015), improve market value (Cai & He, 2013) and by meeting the different needs of diverse stakeholders, allows them to access and invest in tangible and intangible resources and thus achieve superior financial performance (Hou, 2019).

The literature focuses mainly on the impacts of CSR as a uniform structure, and does not address the impacts of its dimensions (such as CSR power and CSR concern) and about their impacts on corporate innovation performance. In the stakeholder theory, stakeholders perceive the firm's environmental behaviors and respond to what is important

\* Corresponding Author, Tel: +98 916 111 5579

Email address: gh.amirnejad@iau-shoushtar.ac.ir

for corporate innovation (Harrison et al., 2010).

Given what was stated above, the present study aims to investigate the impact of corporate social responsibility on innovative performance by considering the mediating role of marketing effectiveness in Khuzestan Steel Industries. A closer look at Khuzestan Steel Industries represents that the following issues are evident in this strategic industry:

- The performance of this industry deviates from predetermined plans
- This industry faces many problems in international marketing
- The industry's share in many international markets has declined significantly
- The quality of products in this industry has not significantly improved compared to competitors

Accordingly, the present study seeks to answer the question of "Does corporate social responsibility affect innovative performance in Khuzestan Steel Industries by considering the mediating role of marketing effectiveness?" Despite the importance of corporate social responsibility and its impact on the innovative performance of corporates, no study has been conducted to investigate this relationship in Iran. There is a research gap in this regard and the present study seeks to fill it. In terms of operational and organizational importance and necessity, this research can be very helpful to senior managers of Khuzestan Steel Industries to develop strategies to improve innovative performance based on social responsibility and marketing effectiveness.

## 2. Research objectives

Main objective: Explaining the impact of corporate social responsibility on innovative performance by considering the mediating role of marketing effectiveness in Khuzestan Steel Industries.

### 2.1. Secondary objectives:

- Explaining the impact of corporate social responsibility on innovative performance in Khuzestan Steel Industries.
- Explaining the impact of marketing effectiveness on innovative performance in Khuzestan Steel Industries.

## 3. Research Hypotheses

Main Hypothesis: Corporate social responsibility has a significant impact on innovative performance with a mediating role of marketing effectiveness in Khuzestan Steel Industries.

### Secondary hypotheses:

- Corporate social responsibility has a significant impact on marketing effectiveness in Khuzestan Steel Industries.
- Marketing effectiveness has a significant impact on innovative performance in Khuzestan Steel Industries.

Since steel is a strategic commodity, regardless of technological advances, its production and consumption process largely depends on international developments. In other words, issues such as economic crises, oil energy, political developments, and war affect the production and

consumption of steel products. The improvement in the steel industry is not very satisfactory, since the export of steel products is very small compared to the total exports of the country. Thus, this industry and its performance have been considered in this research. We will address some cases of different studies that have been conducted in Iran and foreign countries and are, somehow, in line with the subject of this study.

In a study entitled "The impact of quantitative indicators of corporate social responsibility on financial and economic performance fluctuations in corporates listed on Tehran Stock Exchange", (Nik Kar & Yousefi, 2019), showed that the ratio of the number of employees to total assets and the ratio of taxes to total assets as indicators of corporate social responsibility reduce the fluctuations of financial and economic performance of the corporate. Also, the results confirm that the ratio of fixed assets to total assets of the corporate, the ratio of research, development and advertising costs to sales and corporate governance ability as indicators of corporate social responsibility, have a significant impact on fluctuations in financial and economic performance.

In a study entitled "The impact of innovation on the financial performance of corporates in various industries considering the moderating role of social responsibility", (Namazi & Moghimi, 2018), showed that in the Tehran Stock Exchange, innovation in the pharmaceutical, chemical and plastic industries compared to other industries, has a greater impact on financial performance. Social responsibility in the minerals and pharmaceuticals, chemicals and rubber industries has a greater impact on the financial performance of corporates than other industries. As social responsibility increases, the performance of corporates improves significantly. When social responsibility is considered as a moderating variable, the power of the model increases in all industries, but its impact is greater in the tile, cement, lime and gypsum, and minerals industries than other industries. These results suggest the importance of innovation and social responsibility in the performance of the organization.

In a study entitled "Competitive strategies, corporate performance and social responsibility as a third strategy", (Hajiha, 2018) examined the relationship between the type of business strategy and the level of disclosure of corporate social responsibility information on performance. The model of Salazar (2017) was used to measure the type of business strategy and the model of Mishra et al was used to measure the level of disclosure of corporate social responsibility. The study period was during 2011-2015 and the selected sample consists of 96 corporates listed on Tehran Stock Exchange. The results of the research suggest that competitive strategies have a direct and significant impact on the performance. The impact of social responsibility on performance is also direct and significant, but by the presence of more disclosure of social responsibility, the differentiation strategy has a greater impact on performance than cost reduction.

In a research entitled "Investigating the relationship between corporate social responsibility and customer loyalty with the mediating role of ethical standards,

customer satisfaction and trust (a case study of customers of private banks in Bojnourd)", (Mahnani, 2018) showed that there was a significant relationship between the value and commitment to social responsibility. There was a significant relationship between ethical standards and commitment to social responsibility. There was a significant relationship between commitment to social responsibility and customer satisfaction. There was a significant relationship between commitment to social responsibility and customer trust. There was a significant relationship between customer satisfaction and customer loyalty. There was a significant relationship between customer trust and customer loyalty.

In a study entitled "Impacts of corporate environmental responsibility and concern about innovation performance: the mediating role of corporate vision", (Wu et al., 2019) examined the impacts of two dimensions of corporate environmental responsibility on corporate innovation performance and the mediating impact of corporate vision on these relationships. Using data from Chinese corporates listed on Shenzhen Stock Exchange from 2006 to 2015, this research showed that corporate environmental responsibility resistance has a positive impact on corporate innovation performance, while corporate environmental responsibility concern negatively affects innovation performance. These relationships are stronger for corporates that have more vision. This research provides insights into understanding the relationship between innovation performance and responsibility, and provides important management concepts for corporates to manage their environmental behaviors and improve innovation performance to achieve sustainable development.

In a study entitled "Corporate social responsibility on service innovation performance: The mediating role of dynamic ability for sustainability", (Li et al., 2019) examined the relationship between corporate social responsibility and service innovation performance. Based on social capital and dynamism theory, they developed a model that demonstrates that corporate social responsibility improves service innovation performance through enhanced dynamic capability to address rapidly changing environments. By using structural equation modeling and hierarchical regression analysis, they tested the conceptual model with data sets from 298 SMEs in China. The results represented that positive impact of corporate social responsibility on service innovation performance is partly mediated by dynamic capability, while this part of CSR environment is fully mediated by dynamic capability. These results have important implications for both corporate social responsibility and service innovation theory.

In a study entitled "Corporate social responsibility and marketing strategy: Impact on customer purchasing decision", (Salazar, 2017) investigated the impact of marketing mix and consumer social responsibility in relation to intention to pay higher prices for products made by corporates with social responsibilities. A survey of 270 consumers in the food industry was conducted in Celaya (Mexico). The results showed that product, place and advertising strategies in general and consumer social

responsibility have a positive and significant impact on consumer intention to pay higher prices for products made by a corporate with a corporate social responsibility strategy. In a study entitled "Corporate social responsibility and marketing performance with mediating role of intensity of advertising", (Rahman et al., 2017) stated that the relationship between corporate social responsibility initiatives and corporate performance has been extensively investigated, but the results have been contradictory. The association between corporate social responsibility and marketing, as one of the dimensions of corporate performance, has not yet been explored. This study examines the relationship between corporate social responsibility activities (in particular, corporate population and environmental activities) and marketing performance (measured by market share) and reveals a positive relationship in this regard. The results of this study show that the level of advertising intensity moderates the positive relationship between social responsibility and market share.

#### **4. Conceptual model of research**

According to the studies conducted in the theoretical foundations and research background, the conceptual model of the research is developed in Figure 1. Based on this model, corporate social responsibility variable is considered as an independent variable and innovative performance variable as dependent variable. According to the hypothetical relationships of this model, the corporate social responsibility variable can directly affect the innovative performance variable and indirectly through the intermediary variable of marketing effectiveness. Innovative performance has been adapted from Suzbelier's research, which includes innovation in introducing a new product, use of innovative technologies, speed of new product development, number of new products introduced to the market, number of products first introduced by the corporate to the market, corporate's technological competition, the speed of adaptation to new technologies, the number of new technologies used and the rate of change in processes and technology. Corporate social responsibility was adapted from the research conducted by (Li et al., 2019), which includes donating money to donors, significant financial contributions to public welfare events, protecting community stability, actively participating in community events, and behaving in accordance with environment protection rules and regulations, having a comprehensive program to protect the environment, using bio-friendly energy, and trying to use non-renewable resources. Also, marketing effectiveness has been adapted from the research conducted by (Steurer et al., 2005), which included measures such as customer orientation, customer satisfaction, integrated marketing activities, collection of marketing information, strategic market orientation, and market share, and market growth.

#### **5. Material and methods**

This study was an applied research in terms of aim, descriptive-survey in terms of approach and causal in terms of data analysis method.

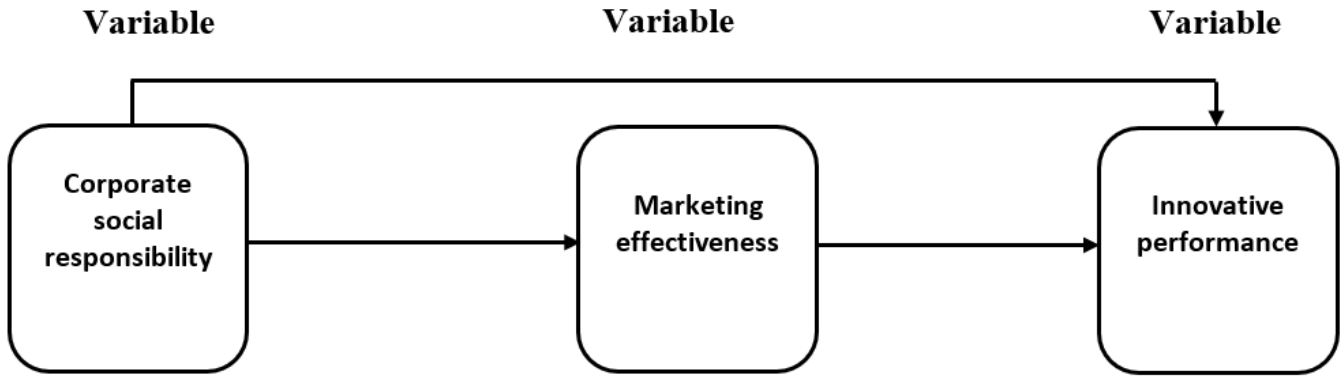

**Figure1.** Conceptual model of research ((Wu et al., 2019); (Rahman et al., 2017))

The statistical population of the study included all 1500 employees of Khuzestan Steel Industries. Cochran's formula was used to determine the sample size and 306 people were selected as the sample. Library and field methods were used for collecting data. In the field stage, to collect data to test the research hypotheses of three questionnaires including: corporate social responsibility questionnaire by 14 standard questions, innovative performance questionnaire by 14 standard questions and a marketing effectiveness questionnaire with 15 standard questions were used. Face validity was used to evaluate the validity of the questionnaire. Accordingly, the questionnaire questions were first designed and given to several experts and professors specialized in management. After reviewing and commenting on the experts and professors and editing the questions, the final questionnaire was developed. Also, the validity of the research questionnaire was assessed through confirmatory factor analysis in LISREL software. To evaluate the reliability of the questionnaires, Cronbach's alpha method was used, the value of which was obtained at 0.8. Finally, to analyze the statistical data and study the research questions in SPSS and LISREL statistical software, descriptive statistics and inferential tests appropriate to the type of data and variables were used.

## 6. Results

### A. Descriptive results

As mentioned, 306 people were selected as a sample and questionnaires were provided to them. After completing and reviewing them, it was found that 89.21% were male and 10.78% were female respondents. In terms of age group, 17.32% were under 30 years old, 38.88% were between 30 and 45 years old, 39.86% were between 45 and 60 years old, and 3.92% of them were over 60 years old. In terms of education, 12.74% had an associate's degree or below, 24.50% had a bachelor's degree, 50.32% had a master's degree, and 12.41% had a PhD. In terms of employment history, 21.89% had less than 10 years of employment history, 34.64% had 10 to 20 years of employment history, and 43.46% had more than 20 years of employment history in Khuzestan Steel Industries.

### B. Inferential results

Testing the main research hypothesis

**Main Hypothesis:** Corporate social responsibility has a significant impact on innovative performance with a mediating role of marketing effectiveness in Khuzestan Steel Industries.

**H0:** Corporate social responsibility has no significant impact on innovative performance with a mediating role the marketing effectiveness in Khuzestan Steel Industries.

**H1:** Corporate social responsibility has a significant impact on innovative performance with a mediating the marketing effectiveness in Khuzestan Steel Industries.

In implementing the structural equation model based on (Figure 2) and (Figure 3), to test the main research hypothesis, first, the software output indicates the appropriateness of the fitted structural model ( $X^2/df = 1.27$ ;  $RMSEA = 0.042$ ;  $GFI = 0.93$ ;  $AGFI = 0.91$ ;  $NFI = 0.98$ ,  $NNFI = 0.99$ , and  $CFI = 0.99$ ). In other words, the observed data are largely consistent with the conceptual model of the research. The following diagrams represent the significance of the coefficients and parameters obtained from the structural model of the research, as all numbers are greater than 1.96. The results of structural equation model show that corporate social responsibility has a significant impact on innovative performance with a mediating role the marketing effectiveness in Khuzestan Steel Industries. Therefore, the null hypothesis is rejected and the main hypothesis of the research is confirmed. Also, the impact of the path coefficient between the variables in the standard estimation mode model is 0.79, 0.10 and 0.38, and T coefficients in the significant mode model are equal to 12.65, 3.08 and 4.45, so T coefficients are larger than 1.96.

### 6.1. Discussion

**Secondary hypothesis 1:** Corporate social responsibility has a significant impact on marketing effectiveness in Khuzestan Steel Industries.

**H0:** Corporate social responsibility does not have a significant impact on marketing effectiveness in Khuzestan Steel Industries.

**H1:** Corporate social responsibility has a significant impact on marketing effectiveness in Khuzestan Steel Industries.

In implementing the structural equation model to test the main research hypothesis in Figure2 and Figure3, firstly,

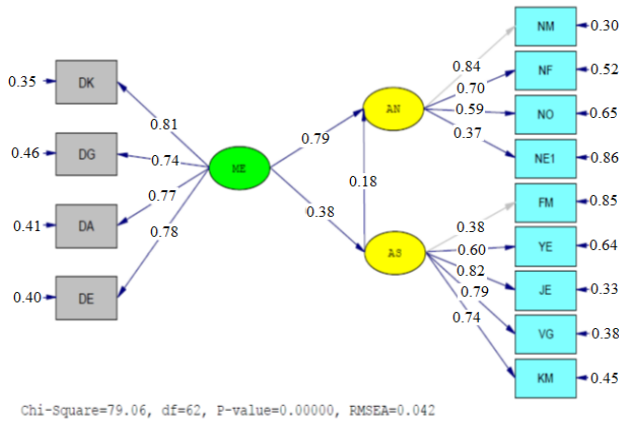

**Figure2.** Research model in standard estimation mode

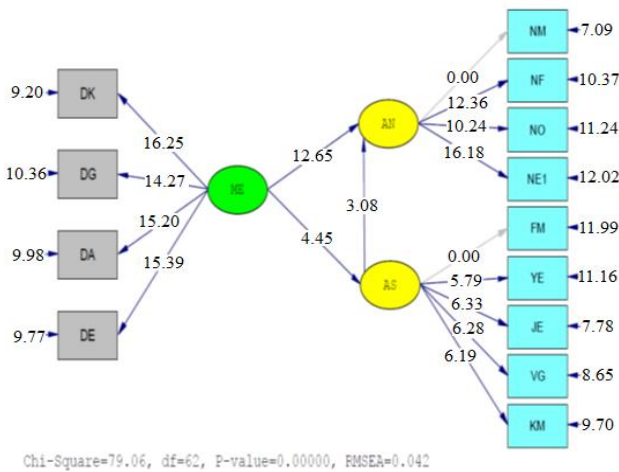

**Figure3.** Research model in the significant numbers mode

the software output indicates the appropriateness of the fitted structural model ( $X^2/df = 1.27$ ;  $RMSEA = 0.042$ ;  $GFI = 0.93$ ;  $AGFI = 0.91$ ;  $NFI = 0.98$ ,  $NNFI = 0.99$ , and  $CFI = 0.99$ ). In other words, the observed data are largely consistent with the conceptual model of the research. The below diagrams also show the significance of the coefficients and parameters obtained from the structural model of the research that the significance coefficient of the numbers is less than 1.96. According to the structural equation obtained at the significance level of 0.05, the null hypothesis is rejected. As a result, the researcher's hypothesis is confirmed with 0.95% confidence and with an error rate of 5%. Hence, it can be stated that corporate social responsibility has a significant impact on marketing effectiveness in Khuzestan Steel Industries. The path coefficient of the variables is 0.38 and its significance is 4.45.

### 6.2. Secondary hypothesis

2: Marketing effectiveness has a significant impact on innovative performance in Khuzestan Steel Industries.  
 H0: Marketing effectiveness has no significant impact on innovative performance in Khuzestan Steel Industries.  
 H1: Marketing effectiveness has a significant impact on innovative performance in Khuzestan Steel Industries.  
 The results of structural equation model showed that

marketing effectiveness has a significant impact on innovative performance in Khuzestan Steel Industries. Therefore, the null hypothesis is rejected and the research hypothesis is confirmed. Also, the impact of path coefficient between variables in the standard estimation mode model is 0.10 and the T-coefficient in the significance mode model is 3.08, so T-coefficient is greater than 1.96 (Figure 2) and (Figure 3), Secondary hypothesis

3: Corporate social responsibility has a significant impact on innovative performance in Khuzestan Steel Industries.

H0: Corporate social responsibility does not have a significant impact on innovative performance in Khuzestan Steel Industries.

H1: Corporate social responsibility has a significant impact on innovative performance in Khuzestan Steel Industries.

The results of structural equation model show that corporate social responsibility has a significant impact on innovative performance in Khuzestan Steel Industries. Therefore, the null hypothesis is rejected and the secondary hypothesis 3 is confirmed. Also, the impact of path coefficient between variables in the standard estimation mode model is 0.79 and the T-coefficient in the significance mode model is 12.65, which is greater than 1.96.

## 7. Conclusions

The main hypothesis of the research stated that corporate social responsibility has a significant impact on innovative performance in Khuzestan Steel Industries. The results of data analysis showed that the significant number between these two variables is 10.95 and since, this value is more than 1.96, the main hypothesis of the research is confirmed. Also, the results of data analysis showed the positive impact of corporate social responsibility on innovative performance at a rate of 0.14. It means that by investing in the area of social responsibility, innovative performance can be strengthened in Khuzestan Steel Industries. The first secondary hypothesis of the research stated that corporate social responsibility has a significant impact on marketing effectiveness in Khuzestan Steel Industries. The results of data analysis showed that the significant number between these two variables is 12.02 and since this value is more than 1.96, the main hypothesis of the research is confirmed. Also, the results of data analysis showed the positive impact of corporate social responsibility on marketing effectiveness at a rate of 0.67. It means that by investing in social responsibility, the effectiveness of marketing activities can be strengthened in Khuzestan Steel Industries. The second secondary hypothesis of the study stated that marketing effectiveness has a significant impact on innovative performance in Khuzestan Steel Industries. The results of data analysis showed that the significant number between these two variables is 4.54 and, since this value is more than 1.96, the main hypothesis of the

research is confirmed. Also, the results of data analysis showed a positive impact of marketing effectiveness on innovative performance at a rate of 0.1. It means that by strengthening the marketing effectiveness, innovative performance can also be strengthened in Khuzestan Steel Industries. The third secondary hypothesis of the research stated that marketing effectiveness plays a mediating role in the impact of corporate social responsibility on innovative performance in Khuzestan Steel Industries, the. The results of data analysis showed that this mediating role is confirmed. It means that fulfilling social responsibilities can also have a direct positive impact on innovative performance in Khuzestan Steel Industries. It can also positively affect the marketing effectiveness and thereby influence innovative performance.

### Practical Recommendations for Managers

Based on the results of the present study, the following recommendations can be provided to the managers of Khuzestan Steel Industries to strengthen innovative performance:

- Corporates operating in Khuzestan Steel Industries should try to be known as an innovative corporate in introducing new products.
- Corporates operating in Khuzestan Steel Industries should accelerate the development of their new products.
- Corporates operating in Khuzestan Steel Industries should use innovative technologies.
- Corporates operating in Khuzestan Steel Industries should try to be in a technological competition with competitors.
- Corporates operating in Khuzestan Steel Industries should quickly adapt to new technologies.
- Corporates operating in Khuzestan Steel Industries should increase the rate of change in processes and technologies.
- Corporates operating in Khuzestan Steel Industries should spend annually on charity affairs.
- Corporates operating in the Khuzestan Steel Industries should provide significant financial support to public welfare events.
- Corporates operating in Khuzestan Steel Industries should support the stability of society.
- Corporates operating in Khuzestan Steel Industries should play an active role in social events.
- Corporates operating in Khuzestan Steel Industries should behave in accordance with the rules and regulations related to environmental protection.
- Corporates operating in Khuzestan Steel Industries have complete and well-developed plans for environmental protection.
- Corporates operating in Khuzestan Steel Industries should use bio-friendly energy.
- Corporates operating in Khuzestan Steel Industries should use more renewable resources and energies rather than non-renewable resources and energies.
- Corporates operating in Khuzestan Steel Industries should value their customers.
- Corporates operating in Khuzestan Steel Industries

should focus on the current and future needs of customers.

- Corporates operating in Khuzestan Steel Industries should have a strategic marketing plan.
- In the corporates operating in Khuzestan Steel Industries, marketing measures should be designed in an integrated way.
- Corporates operating in Khuzestan Steel Industries should collect up-to-date information about customers.
- Corporates operating in Khuzestan Steel Industries should collect up-to-date information about competitors.
- Corporates operating in Khuzestan Steel Industries should collect up-to-date information on industry developments.

### References

- Cai L. & Cui J. & Jo H. (2015), corporate environmental responsibility and firm risk. *Journal of Business Ethics*, 139(1): 563-594.
- Cai L. & He C. (2013), Corporate environmental responsibility and equity prices. *Journal of Business Ethics*, 125(1): 617-635.
- Hajiha Z. (2018), Competitive strategies, corporate performance and social responsibility as the third strategy. *Management Accounting*, 36(11): 31-43.
- Harrison JS. & Bosse DA. & Phillips RA. (2010), Managing for stakeholders, stakeholder utility functions, and competitive advantage. *Strategic Management Journal*, 31(1): 58-74.
- Hou TCT. (2019), The relationship between corporate social responsibility and sustainable financial performance: Firm-level evidence from Taiwan. *Corporate Social Responsibility and Environmental Management*, 26(1): 19-28.
- Li L. & Li G. & Tsai FS. & Lee HY. & Lee CH. (2019), The effects of corporate social responsibility on service innovation performance: The role of dynamic capability for sustainability. *Sustainability*, 11(10): 2739-2748.
- Mahnani A. (2018), Investigating the relationship between corporate social responsibility and customer loyalty with the mediating role of ethical standards, customer satisfaction and trust (Case study of customers of private banks in Bojnourd), *Management Accounting Perspectives*, 1(1): 31-38.
- Namazi M. & Moghimi F. (2018), The impact of innovation on the financial performance of corporates in various industries with the moderating role of social responsibility. *Accounting and Auditing Reviews*, 25(2): 289-310.
- Nik Kar J. & Yousefi M. (2019), The impact of quantitative indicators of corporate social responsibility on fluctuations

in financial and economic performance in corporates listed on the Tehran Stock Exchange. *Accounting Research*, 9(1): 157-176.

Pisano GP. (2015), You need an innovation strategy. *Harvard Business Review*, 93(1): 22-22.

Rahman M. & Rodríguez-Serrano M<sup>Á</sup>. & Lambkin M. (2017), Corporate social responsibility and marketing performance: The moderating role of advertising intensity. *Journal of Advertising Research*, 57(4): 368-378.

Salazar GLL. (2017), The Corporate Social Responsibility and the Marketing Strategy: Influence on the Customer's Purchase Decision. *International Journal of Business and Social Science*, 8(2): 25-39.

Steurer R. & Langer ME. & Konrad A. & Martinuzzi A. (2005), Corporations, stakeholders and sustainable development I: A theoretical exploration of business-society relations. *Journal of Business Ethics*, 61(1): 263-281.

Wu W. & Liang Z. & Zhang Q. (2019), Effects of corporate environmental responsibility strength and concern on innovation performance: The moderating role of firm visibility. *Corporate Social Responsibility and Environmental Management*, 4(3): 18-26.