

Development of Seismic Criteria for Seismic Responses of Regular and Irregular Structures in Plan considering Vertical Component of the Near-field Records

Maryam Firoozi Nezamabadi^{*a}, Fariborz Yaghoobi Vayeghan^b

^a Department of Civil Engineering, South Tehran Branch, Islamic Azad University, Tehran, Iran

^b Department of Civil Engineering, Pardis Branch, Islamic Azad University, Pardis, Iran

Received 7 December 2014; Accepted 20 March 2015

Abstract

Field observations of the incurred damages to the buildings and bridges due to earthquakes in near field show there are various failure modes which are in relation to the forces caused by vertical component. While vertical component of earthquake for ordinary buildings in most seismic regulations and standards is not considered. Therefore, in the current study the effects of vertical and horizontal components of earthquake on regular and mass asymmetric structures are investigated simultaneously. The study considers a model of one-story structure with 3 degrees of freedom, lateral displacement, torsional displacement of roof level and vertical displacement, on a rigid foundation. It is concluded that for all such structures in the near-fault zones, the effect of vertical component must be considered. In case of stiff structures, the effect of the force on displacement of such structures is of importance and the effect of vertical component can be disregarded. The use of vertical design response spectrum to calculate the vertical forces caused by near field earthquakes is also recommended.

Keyword: Seismic Responses, Regular and Irregular Structures in Plan, Vertical Component, Near-field Effects, Iranian Code of Practice for Seismic Resistant Design of Buildings (Standard No.2800)

1. Introduction

Field observations of the earthquakes in near field regions such as Northridge (1994), Kobe (1995), Turkey (1995), Athens (1999), Bam (2003) and analytical results, indicate that certain failure modes are more convincingly attributable to high vertical earthquake-induced forces. The failure modes relating to the vertical component are caused by either compression forces or tensile forces or effects of tensile forces in reduction of shear strength [1-3]. The vertical excitation can reduce or vary the distribution of energy among the elements of the frames, with a possible greater demand in the columns [4]. The main effect of the vertical motion is variation of axial force in columns. The high values of compression, or even tension, induced by the vertical excitation could produce damage in the structure which leads to a decrease of structural capacity to withstand the horizontal seismic motion, resulting in an increase of horizontal displacements in nonlinear behavior [1-6]. The change of axial force in stiff structures (i.e., period less than 0.4 seconds) is much more than in structures with medium or

high periods [7]. The varying axial force in the columns results in pinched hysteretic behavior that causes larger horizontal displacement and column end moments and curvature [8]. The vertical component has also the significant effect of changing the plastic hinge distribution, sequence of hinging and mode of failure of the structure [8-9]; even though, it increases the design forces of the non-structural components joints [10]. Moreover, it changes the cracking model of piers of concrete bridges from flexural ductility fracturing to brittle shear fracturing [11].

The studies on vertical acceleration show that it is much larger in near-field than far-field and by increasing in distance this acceleration component will reduce more than horizontal ones. The ratio of vertical to horizontal acceleration is a function of period and is much larger in short periods than long periods. When the period is between 0.05 to 0.1 seconds, the ratio is at maximum value and when the period is between 0.4 to 0.8 seconds, the ratio is at minimum value. This ratio will increase

 * Corresponding Author Email: firoozi@azad.ac.ir

slowly in higher periods. Meanwhile, this ratio increases to reach 1 in near-field records [12].

Most of the codes and standards assume a value of 2/3 to scale vertical spectrum from horizontal spectrum which is not conservative for the near-fault areas. This is one of the short comings about effect of vertical component in seismic codes [13].

Another shortcoming of seismic codes regarding vertical ground motion is the assumption that all the earthquake components have the same frequency content, while the vertical ground motion has higher frequency content. The maximum vertical spectral acceleration for El-Centro record is at the period about 0.1 second and for Northridge and Kobe earthquakes it is between 0.25 and 0.35 seconds. The other important point is that all the energy content of the vertical component concentrates on a narrow high-frequency range and the other difference is the amplitude of vertical component in the case of near-fault records. Therefore, the other problem of seismic codes is the non-conservative definition of period values of the spectrum boundaries [14] which has been modified in the EuroCode8, but not in the other codes.

The effect of the vertical component on a case of regular and irregular concrete structures is studied by Kim and Elnashai [2] and [15]. The irregular structure has six rows of columns, two of which are cut in the first floor. According to this study, taking vertical component into consideration causes increase in axial forces in the columns of regular and irregular structures; moreover, the change in axial forces leads to a decrease in the shear capacity of the vertical components (columns) and an increase in the shear failure potential of the components. Although, this will not affect the relative displacement and ductility demand curves of regular structures; but, it significantly change those of irregular structures [2] and [15].

Another study on the effect of vertical component in behavior of torsional models is done by Gupta and Hutchison [16]. First they presented some mathematical relations for a simplified model with three degrees of freedom (3-D.O.F), including: horizontal displacement (u), torsional displacement (u_0), and vertical displacement (v). Then, the model has been verified using the above mentioned relations in linear range subjected to two earthquake records; north-south component of El-Centro (1940) and Konya (1967). In the current study, after developing the three degree-of-freedom simplified model presented by Gupta and Hutchison, the effect of vertical component has been studied on a wide range of regular and irregular structures. The structural degrees of freedom include: horizontal displacement (u), torsional displacement (u_0), and vertical displacement (v) [1].

At the first phase of the present study, all models are once nonlinear analyzed taking only horizontal component of earthquake into consideration, then both vertical and horizontal components has been considered using seven 3-component near-field earthquake records recorded on soil type II in OpenSees Software. In second phase, the

obtained results from the previous phase are compared to the acceptance of criteria of Standard No. 2800 and finally, some recommendations are derived for buildings with periods equal to 0.2 seconds and less.

This study shows that the effect of vertical component must be taken into consideration for all structures located in the near-field areas. Of course, for very stiff structures only the force is significant and the effect of vertical component on displacement of these structures may be ignored. It is also strongly recommended that a vertical response spectrum, like those presented in this study, shall be used to calculate the vertical forces due to earthquakes occurred in the near-field areas.

2. Consideration of vertical component in American and European seismic codes

1.1. American code [17]

According to this regulation, each building is analyzed and designed once with and once without considering vertical component. According to clause 1617.1.1.1, vertical component of earthquake is calculated as $(0.2 \times S_{DS} \times D)$.

$$E = \rho Q_E \pm 0.2 S_{DS} D \quad (1)$$

Where:

E, is combinational effect of vertical and horizontal forces; D, is dead load effect; ρ , is redundancy factor; Q_E , is the effect of horizontal forces; and S_{DS} , is acceleration response design spectrum in short periods.

In this code, design response spectrum is illustrated in fig (1) using the following relations:

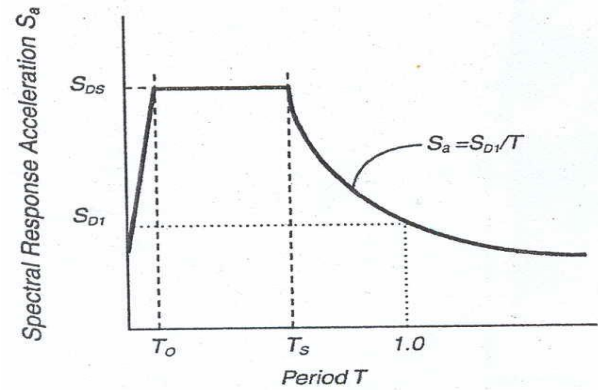

Figure (1): Design acceleration response spectrum

$$S_{DS} = \frac{2}{3} S_{MS} \quad (2)$$

$$S_{MS} = F_a S_s \quad (3)$$

Where:

T , is fundamental period of vibration of the structure in the direction under consideration, in second; F_a , is site effect factor; S_{MS} , is the maximum spectral acceleration responses for short periods; and S_s , is spectral accelerations for short periods.

1.2. European Code [18]

According to this code, the vertical component of the seismic action should be taken into account in the cases below, if the design ground acceleration in the vertical direction is greater than 0.25g:

1. For horizontal or nearly horizontal structural members spanning 20 m or more;
2. For horizontal or nearly horizontal cantilever components longer than 5 m;
3. For horizontal or nearly horizontal pre-stressed components;
4. For beams supporting columns;
5. In base-isolated structures.

The analysis for determining the effects of the vertical component of the seismic action may be based on a partial model of the structure, which includes the elements on which the vertical component is considered to act and takes into account the stiffness of the adjacent elements. On the other hand, the effects of the vertical component are needed to be taken into account only for the elements under and their directly associated supporting elements or substructures. If the horizontal components of the seismic action are also relevant for these elements the following combinations may be used for the computation of the action effects:

$$0.3E_{dx} + 0.3E_{dy} + E_{dz} \tag{4}$$

$$E_{dx} + 0.3E_{dy} + 0.3E_{dz} \tag{5}$$

$$0.3E_{dx} + E_{dy} + 0.3E_{dz} \tag{6}$$

If non-linear static (pushover) analysis is performed, the vertical component of the seismic action may be neglected.

E_{dx} and E_{dy} are the horizontal components and E_{dz} is the vertical component of earthquake.

The schematic spectrum is demonstrated in fig (2):

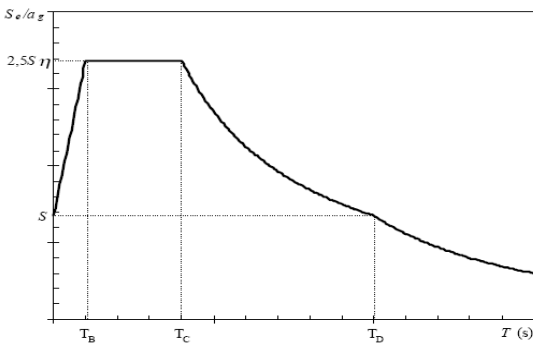

Figure 2: Elastic response spectrum

The vertical component of the seismic action shall be represented by an elastic response spectrum derived using following expressions:

$$\begin{cases} 0 \leq T \leq T_B : S_{ve}(T) = a_{vg} \left[1 + \frac{T}{T_B} (3.0\eta - 1) \right] \\ T_B \leq T \leq T_C : S_{ve}(T) = a_{vg} \times \eta \times 3.0 \\ T_C \leq T \leq T_D : S_{ve}(T) = a_{vg} \times \eta \times 3.0 \left[\frac{T_C}{T} \right] \\ T_D \leq T \leq 4s : S_{ve}(T) = a_{vg} \times \eta \times 3.0 \left[\frac{T_C \cdot T_D}{T^2} \right] \end{cases} \tag{7}$$

Where:

$S_{ve}(T)$ is vertical elastic response spectrum; T is vibration period of a linear single-degree-of-freedom system, a_{vg} ; is vertical design ground acceleration; a_g is horizontal design ground acceleration; T_B and T_C are limits of the constant spectral acceleration branch. T_D is value defining the beginning of the constant displacement response range of the spectrum; S is soil factor; and η is damping correction factor may be determined by the following expression with reference value $\eta = 1$ for 5% viscous damping.

$$\eta = \sqrt{\frac{10}{(5 + \xi)}} \geq 0.55 \tag{8}$$

ξ is viscous damping ratio of the structure and the amounts of T_B , T_C , T_D and a_{vg}/a_g can be obtained using table (1).

Table (1): Amounts of T_B , T_C , T_D and a_{vg}/a_g according to Eurocode 8, 2002

	a_{vg}/a_g	T_D	T_C	T_B
Areas where $M_s \geq 5.5$	0.90	1.0	0.15	0.05
$M_s < 5.5$ Areas where	0.45	1.0	0.15	0.05

1.3. Iranian code of practice for seismic resistant design of buildings [19]

The vertical seismic load shall be considered for design in the following cases:

- (a) Beams with spans exceeding 15 meters. The adjacent columns and supporting walls shall also be considered.
- (b) Beams with considerable concentrated loads, with respect to other applied loads. The adjacent columns and supporting walls shall also be considered. A considerable concentrated load is a load with magnitude of at least half of the sum of all other applied loads.
- (c) Balconies and cantilevers

The vertical seismic load for cases (a) and (b), above, shall be determined from eq. (9). For the case (c), above, this load shall be doubled. Moreover, for this latter case the load shall be considered in both upward and downward directions, ignoring the reducing effect of gravity loads.

$$F_v = 0.7AIW_p \tag{9}$$

In this equation, A is the design base acceleration ratio; I, is the building importance factor; and W_p is the weight of the element plus its total live load.

The vertical and horizontal seismic loads shall be considered in the following load combinations:

- 100 percent of horizontal seismic load in any direction, plus 30 percent of the horizontal load in the perpendicular direction and 30 percent of the vertical seismic load.
- 100 percent of the vertical seismic load plus 30 percent of the horizontal seismic load in any two perpendicular directions.

2. The models and time history analyses

In this study, a simplified three degree-of-freedom model which includes horizontal, torsional and vertical D.O.F is chosen as the base model, which is actually the modified model of Gupta and Hutchison [16], [20-21] (fig 3).

The total mass of the structure (m) in both horizontal and vertical directions, with eccentricity (e) from the center of resistance (that matches the center of the area), is modeled in accordance with the horizontal axis (x) which is caused due to different mass densities of ρ_a , ρ_b and $\rho_a > \rho_b$. In order to investigate the effect of irregularity of the plan on responses of model, each model is considered both as regular and irregular with eccentricities equal to 15% and 30%. The viscous damping ratio (ξ) is supposed to be 5% of critical damping.

In these models, ω_u , $\omega_{\theta z}$ and ω_v represent the translational, torsional and vertical natural frequencies, respectively. The torsional and vertical frequencies ratio

values are defined as $\lambda_{Tz} = \frac{\omega_{\theta z}}{\omega_u}$, $\lambda_v = \frac{\omega_v}{\omega_u}$ and

$\Omega_n = \frac{\omega_n}{\omega_u}$, where ω_n is the natural frequency of

torsional coupled system.

Changing the stiffness values, models which have uncoupled natural period between 0.2 to 2.0 seconds within a time interval of 0.2, are created. Also the effect of changing stiffness on the responses of the models were investigated for cases with torsional frequency ratios (λ_{Tz}) equal to 0.6, 1.0 and 1.4, and vertical frequency ratios (λ_v) equal to 1.0, 10.0 and 20.0.

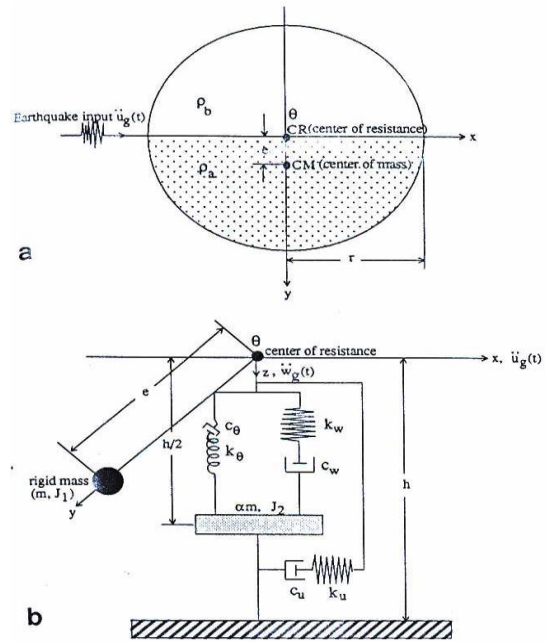

(a) Model introduced in Gupta and Hutchison research

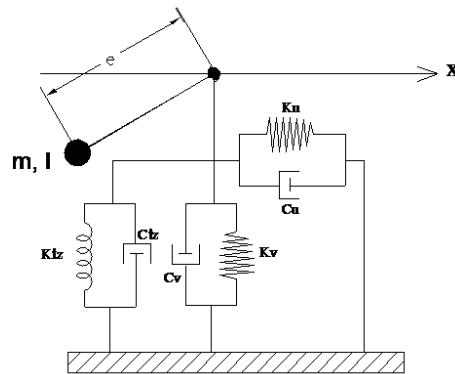

(b) The modified model [21]

Figure (3) Lumped mass model of a single story building

In order to investigate the vertical component effect, all models, are analyzed, at first with no vertical component, then using both vertical and horizontal earthquake components. To compare the linear and nonlinear analysis results, all of the models are analyzed both using linear and nonlinear dynamic procedures, while the accelerations are scaled to 0.35g, 0.70g and 1.05g. In such analyses, three-component near field records are used. The analyses are done by OpenSees software [22]. "Zero-length Element" and the material properties of "Steel01" were used for modeling nonlinear springs. The behavior of this element is described through a bi-linear curve, as shown in fig (4). In this figure, E_0 and b are spring stiffness and strain hardening ratio respectively.

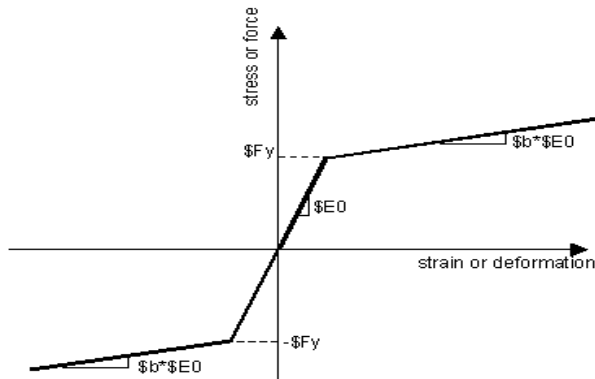

Figure (4) Definition of material properties of "Steel01" in Open Sees software

2.1. Near-Field records

The investigations about near field records show that they have limited frequency contents but higher frequency values, as compared to far field areas. There are severe pulses in displacement and velocity earthquake records [23]. Earthquake energy in the near field areas is also

higher than far field areas, and decreases when distance increases from the source. The research on vertical component effect in near field area specifies that it is much higher than far field area corresponding value and by getting further; this acceleration component value reduces more than horizontal component values. The ratio of vertical and horizontal acceleration component is considerably sensitive to spectral period and the distance from a fault, and it has a maximum value in short periods which is more than 2/3 in the near field areas [24-25].

In the current study, seven sets of near field records were selected from table A1 of Mavroeidis research [26] in which, the soil types is type II, according to Standard No. 2800; the average shear wave velocities are between 375 to 750 m/s; their magnitude were greater than 5.5 in Richter scale; and finally, the distances were up to 15 kilometers from the fault.

The procedure of Standard No. 2800 is used to scale the accelerograms as shown in fig (5). The scale factor was selected such that the average value of the SRSS spectra is not less than 1.4 times the 5 percent damped response spectrum (B on figures) for periods 0.2T seconds to 1.5T seconds on soil type II. The scaled accelerograms are been multiplied by selected scale factor and are used in linear and nonlinear dynamic analyses.

Table (2): Near field acceleration records on soil type II

No.	Record	Date	Station	Distance (Km)	Horizontal Peak Ground Acceleration PGA(g)	Vertical Peak Ground Acceleration PGA(g)	V/H	Shear Wave Velocity V_s (m/s)	M_w
1	Coyote Lake, CA, USA	8-Jun.-79	Gillroy Array 6 (GA6)	1.2	0.434	0.146	0.336	663	5.6
2	Landers, CA, USA	28-Jun.-92	Luceme Valley (Luc)	1.1	0.785	0.818	1.27	685	7.28
3	Loma Prieta, USA	17-Oct.-89	Los Gatos Presentation Center (LGP)	3.0	0.605	0.89	1.65	475	6.93
4	Morgan Hill, CA, USA	24-Apr.-84	Gillroy Array 6 (GA6)	9.9	0.292	0.405	1.39	663	6.19
5	Nahani, Canada	23-Dec.-85	Iverson, NW Territories(Site1)	9.4	1.096	2.086	1.90	659.6	6.76
6	Northridge	17-Jan.-94	Los Angeles Dam (LAD)	5.9	0.511	0.424	0.83	629	6.7
7	Wittier Narrows	10-Oct.-87	Alhambra (ALH)	14.3	0.414	0.19	0.46	550	5.99

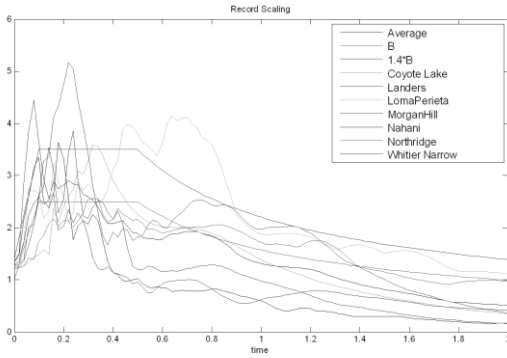

Figure (5): The records spectra [21]

2.2. Nonlinear dynamic analyses results

First, the effect of the vertical component is investigated on the nonlinear dynamic displacement response of structures with different periods. In the next step, the change in axial force of the columns is studied. The results generally show that the displacements of more flexible structures were increased, but the vertical component had a slight effect on the stiffer structures. On the other hand, axial force values of the columns of stiff structures significantly increased.

2.2.1. Displacement responses

In order to compare the results, first, the average value of the resultant of displacement responses derived from the seven time history records in the near-field area was calculated using eq. (10).

$$X_i = \left[(u_i)^2 + (v_i)^2 \right]^{1/2} \quad (10)$$

In this equation, X_i is the resultant displacement, u_i is the horizontal displacement and v_i is the vertical displacement of the structural system in each time step of analysis. Then, the difference ratio of the resultant displacement response of the center of resistance in a 3D.O.F. model (affected by both vertical and horizontal components of earthquake) and a 3D.O.F. model (affected only by horizontal component) is calculated using eq. (11), and are demonstrated in fig (6) and fig (7) as response curves vs. the natural period of uncoupled systems. In this equation, DR represent Difference Ratio and also $X_i(3DOF(H \& V))$ and $X_i(3DOF(H))$ are response of 3D.O.F. model (affected by vertical and horizontal component) and response of 3D.O.F. model (affected by only horizontal component) respectively.

$$DR = \frac{[X_i(3DOF(H \& V)) - X_i(3DOF(H))]}{[X_i(3DOF(H))]} \quad (11)$$

1. According to fig (6), due to vertical component, the increasing ratio of the resistance center response is more than the edge one, because the vertical component, opposite to the horizontal component, affects axial force of the central columns more than edge- columns.
2. With increase in eccentricity, the effect of the vertical component on increasing rate of resistance center response goes up and on increasing rate of edge response comes down.

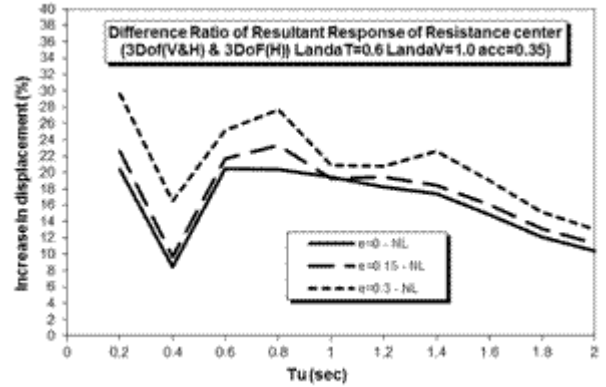

A) Resistance center

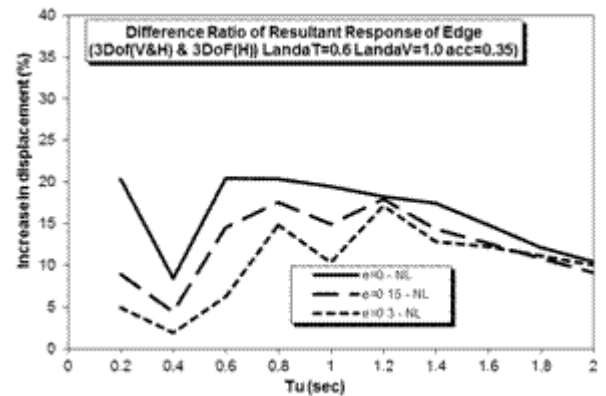

B) Edge

Figure (6): The displacement difference ratio for $\lambda_V=1.0$ [21]

3. By increasing the vertical stiffness (i.e. increase in frequency ratio λ_V) from one to ten and then twenty, the resultant responses of the resistance center and the edge is decreased; so that the maximum rate of change in the response, regarding the effect of vertical component, is about 30%, 0.06% and less than 0.01% if $\lambda_V=1.0$, $\lambda_V=10.0$ and $\lambda_V=20.0$ respectively. Therefore, it can be stated that the existence of vertical component have an insignificant effect on the increasing of the displacement response of structures with higher vertical stiffness (fig 7).

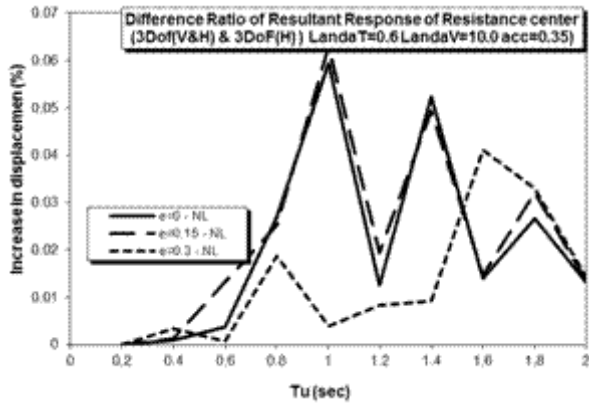

A) $\lambda V = 10.0$ and $\lambda Tz = 0.6$

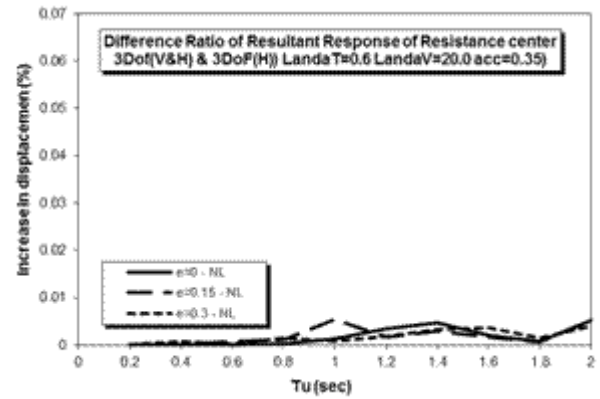

B) $\lambda V = 20.0$ and $\lambda Tz = 0.6$

Figure 7: The displacement difference ratio of resistance center [21]

The difference ratio of the resultant response of the resistance center and edge displacement due to the effect of the vertical component on models, with different eccentricity and torsional frequency for $\lambda_v=1.0$, have been shown in fig (8) and fig (9) respectively. To calculate the resultant displacement of the 3D.O.F. model affected by vertical and horizontal components of earthquake from the response of the resultant displacement of the 3D.O.F model affected by only horizontal components of earthquake, eq. (12) is derived from data regression analysis:

$$X_i(3DOF(H \& V)) = (1 + y) * X_i(3DOF(H)) \quad (12)$$

Where:

$X_i(3DOF(H \& V))$, $X_i(3DOF(H))$ and y , are the resultant displacement of the 3D.O.F model affected by

vertical and horizontal components of earthquake, the response of the resultant displacement of the 3D.O.F model without vertical component of earthquake, and the response correction function based on the fundamental period of vibration of the structure T_u , respectively. Equation (13) is used to calculate the displacement of the resistance center (y_R), and eq. (14) is used to calculate the edge displacement:

$$y_R = -2.72 T_u^2 - 1.42 T_u + 25 \quad (13)$$

Center of resistance

$$y_E = -8.7 T_u^2 + 18.2 T_u + 7.2 \quad (14)$$

Edge

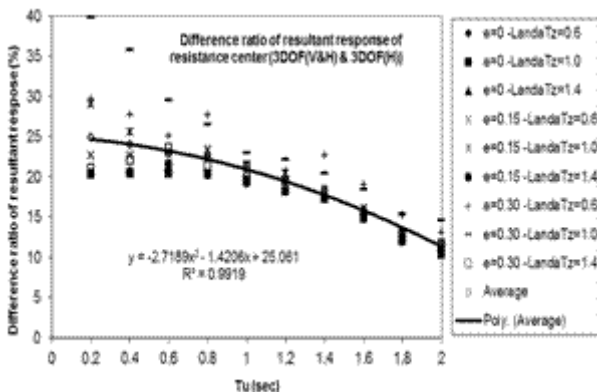

Figure 8: The effect of vertical component on the increase of the nonlinear response of the resultant displacement of the resistance center, for $\lambda V=1.0$ [21]

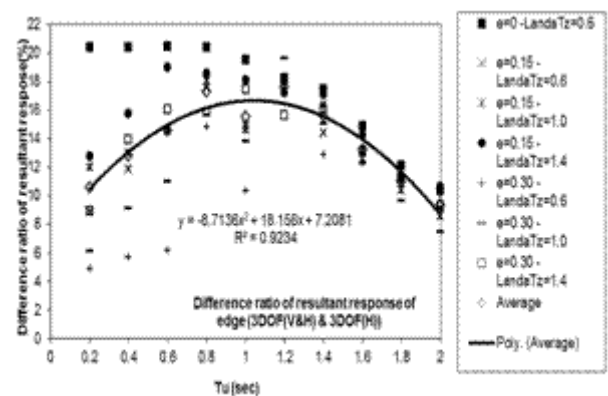

Figure 9: The effect of vertical component on the increase of the nonlinear response of the resultant displacement of the edge, for $\lambda V=1.0$ [21]

2.2.2. Vertical force due to earthquake

Most of the studies in the past showed that the ratio of the maximum response spectrum of vertical to horizontal component of earthquake is more than 2/3 [24-25].

In this study, the ratio between axial force of columns caused by nonlinear dynamic analysis when vertical component exists and base acceleration multiply to model weight ($A \cdot W$) for vertical frequency ratios equal to 1, 10 and 20 are demonstrated in fig (10), fig (11) and fig (12). The horizontal periods are assumed to be between 0.2 to 2.0 seconds with time step of 0.2 second. Vertical period of the models, when the ratio between vertical and horizontal equals to 10, are considered to be between 0.02 and 0.2 second with time step of 0.02; and when the ratio between vertical and horizontal equals to 20, is considered

to be between 0.01 and 0.1 second with time step of 0.01. Figures (10), (11) and (12) show that:

- (a) The ratio of normalized axial force starts from a value close to 1, in periods of 0.01 second and increases to reach its maximum value (about 7.8) in periods of 0.06 to 0.08 second, when $\lambda_V=20$. As the period increases, the value of this factor decreases; so that as shown in fig (12), this ratio for periods between 0.2 to 1.0 second is around 1.8. Then, it increases a little and later, it remains constant.
- (b) Comparing normalized axial force in regular and irregular models in fig (11), there is a significant decrease in irregular models for periods equal to or higher than 0.08 second.

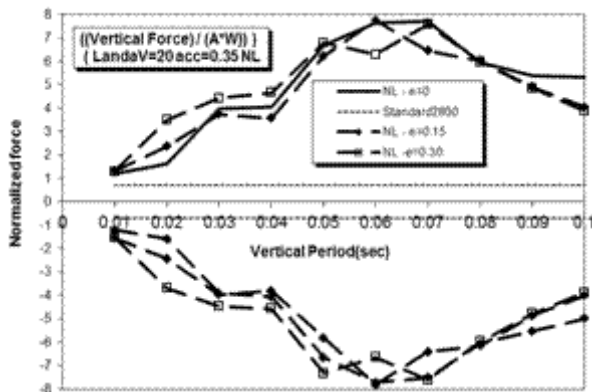

Figure 10: Ratio between axial force of columns due to vertical component and base shear, $\lambda_V=20$ [21]

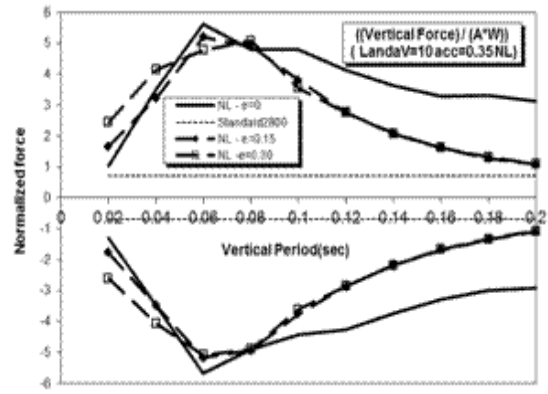

Figure 11: Ratio between axial force of columns due to vertical component and base shear, $\lambda_V=10$ [21]

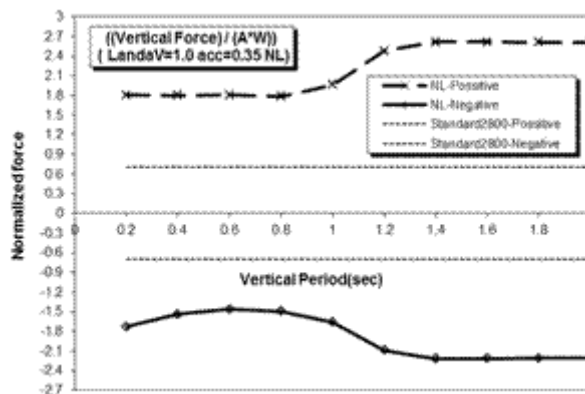

Figure 12: Ratio between axial force of columns due to vertical component and base shear, $\lambda_V=1$ [21]

3. Comparison of the analyses results and the Iranian Standard No.2800

In most seismic codes, vertical component of earthquake for ordinary buildings is not considered or the related provisions have some shortcomings which cannot respect all aspects of this component. The first shortcoming is using the ratio of 2/3 for near-fault areas; the second one is that the frequency content of the vertical component is not considered high; the third is that the periods of spectrum limits are non-conservative; and the fourth is the damping ratio which is considered in the analysis and design should be less than that for horizontal vibration (Elnashai et. al., 2007). Therefore, in the current study the results obtained from the linear and nonlinear dynamic analyses of regular and in-plan irregular structural models with periods less than 2 seconds subjected to simultaneous horizontal and vertical components of earthquake are compared with requirements of Standard No. 2800.

The results are as follows:

1. Regarding to clause 1, 2 and 3 of section 3.2.1 above, the results obtained from nonlinear analyses show that vertical stiffness highly affects the displacement response. Larger vertical stiffness, causes less displacement response; so when the frequency ratio is $\lambda_v=1.0$, the maximum ratio of increase in response of center of resistance and edge are 30% and 20% respectively; and when the vertical frequency ratio is $\lambda_v=10$, the maximum ratio of increase in response is about 0.06%; and finally, when the frequency ratio is $\lambda_v=20$, the maximum ratio of increase in response is less than 0.01%. Thus, one can ignore the effect of vertical component on displacement of structures with large vertical stiffness. Meanwhile, the vertical seismic load shall be considered for calculating the displacement of the structures with low axial stiffness such as industrial structures and other buildings described in clause (2-3-12-1) of Standard No. 2800; the beams with spans exceeding 15 meters and/or with considerable concentrated loads also balconies and cantilevers. The displacement response of the structures due to horizontal and vertical components of earthquake can be calculated using their displacement response from the case with no vertical component then using eq. (12). It should be noted that this equation is presented to demonstrate the procedure and in order to present a general equation, more comprehensive investigations are needed.

2. Regarding clause 4 of section 3.2.2, the response factor of vertical acceleration depends on period and its maximum value is in period range of 0.06 and 0.08 second. When the period increases, this factor decreases and it will be about 1.8 for periods between 0.2 and 1.0 second. Clause (2-3-12-2) of Standard 2800 suggests the eq. (9) as defined above to calculate the vertical seismic load (for balconies and cantilevers this load shall be doubled according to the code).

In that equation, A , is the design base acceleration ratio; I , is the importance factor; and W_p is the weight of the element plus total live load. This equation is period independent and the design base acceleration ratio is multiplied by a constant value; but based on fig (10) to fig (12), the building response factor is not only period dependent, but also its value is more than 0.7. As a result, it is recommended that a design response spectrum of vertical component shall be used to calculate the vertical force due to earthquakes in near-field areas.

3. Using dynamic analyses results and data regression, two spectra, average spectrum (50%) and the average plus one standard deviation spectrum (84.1%) are obtained to calculate the building response factor of vertical acceleration which are very well compatible with the results. Such spectrum can be used to calculate the above factor for structures with periods equal to 2.0 seconds or less.

The average spectra are illustrated in fig (13). These spectra are identified by the following equations:

$$B_v = 90 T_v + 1 \quad 0 \leq T_v \leq 0.06$$

$$R - \text{Squared values} = 0.97747 \quad (15)$$

$$B_v = 6.4 \quad 0.06 \leq T_v \leq 0.08 \quad (16)$$

$$B_v = 0.24 T_v^{-1.24} \quad 0.08 \leq T_v \leq 0.2$$

$$R - \text{Squared values} = 0.9977 \quad (17)$$

$$B_v = 1.8 \quad T_v \geq 0.2 \quad (18)$$

$$R - \text{Squared values} = 0.95 \quad \text{For whole the spectra}$$

In which, B_v is the vertical response spectrum factor for building, T_v is the vertical period of building and R -Squared values represent the compatibility ratio of regression formula with the data values.

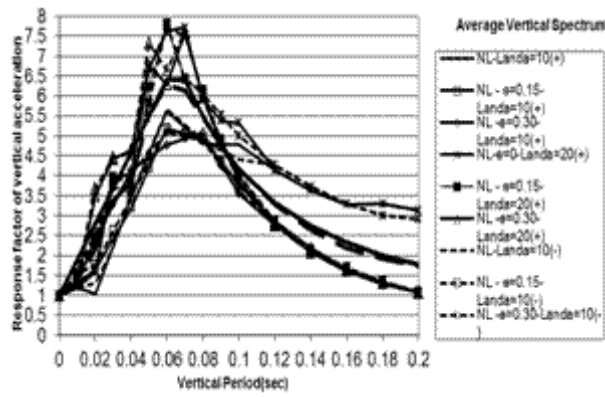

Figure 13: Average vertical response spectrum factor [21]

In fig (14), the average plus one standard deviation spectra are shown. These spectra are calculated by the following equations:

$$B_v = 105 T_v + 1 \quad 0 \leq T_v \leq 0.06 \quad R - \text{Squared values} = 0.9695 \quad (19)$$

$$B_v = 7.3 \quad 0.06 \leq T_v \leq 0.08 \quad (20)$$

$$B_v = 0.24 T_v^{-0.95} \quad 0.08 \leq T_v \leq 0.2 \quad R - \text{Squared values} = 0.989 \quad (21)$$

$$B_v = 2.6 \quad T_v \geq 0.2 \quad (22)$$

$R - \text{Squared values} = 0.965$

For complete spectra

Regarding the fact that the vertical response spectrum factor of irregular models is less than regular ones, it can be suggested that the average spectrum (50%) and

average plus one standard deviation spectrum (84%) used to calculate this factor for irregular and regular buildings in plan respectively.

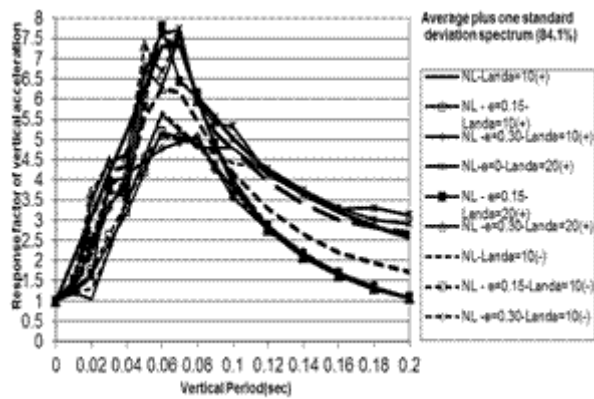

Figure 14: Average plus one standard deviation vertical response spectrum factor [21]

4. With regards to fig (10) to fig (12), the axial force of columns has highly increased as the vertical stiffness increases. This shows that the higher frequency content of vertical component is more than the horizontal one. The more vertical stiffness of structure, the less its period and it is more probable that the period of structure be in the zone of maximum vertical spectrum acceleration. Change in axial force of columns leads to change of behavior of whole structure. The increase in the compressive force causes buckling of steel columns and changing in moment-curvature diagram of concrete columns. Also, the existence of tensile force in columns causes Uplift and it leads to decreasing the shear strength of concrete columns and finally increasing their shear failure potential [2] and [15]. Thus, it seems that the effect of this component shall be taken into consideration for all structures located in near-faults area and clause (2-3-12-1) of the Standard No. 2800, which asks that the effect of this component be considered only in special cases as mentioned above, is not valid for structures in near fault areas.

4. Conclusion

The most important results derived from this study are as follows:

1. The effect of vertical component on displacement of the center of resistance is larger than the edge; because vertical component, in opposite to horizontal component, affect mostly the axial force of central columns rather than columns in the edge.
2. With increase in eccentricity, the effect of vertical component on increasing the resistance center response is larger, and its effect on increasing the edge response is less.
3. When vertical and torsional stiffness increased from 1 to 10 and then to 20 (i.e. increasing in the frequency ratio of λ_v and λ_{Tx}) the responses of the resistance center and edge decreased. So, vertical component has negligible effect on increasing displacement response of structures with large vertical stiffness.
4. The response factor of vertical acceleration depends on period and for period range of 0.06 to 0.08 seconds, it has its maximum value and when the period goes up, the factor decreases. The axial force of columns increases significantly when the vertical stiffness increases from 1 to 10 and 20.
5. The displacement control under vertical component in Iranian Standard 2800 is only necessary for industrial structures and similar structures as described in clause (2-3-12-1). It is shown that it is possible to develop an equation for calculating structural displacement responses when vertical component of earthquake is included. A preliminary equation was presented.
6. According to Standard 2800, the vertical component effect is needed to consider only for structures indicated in clause (2-3-12-1). The current study shows that the effect of vertical component

must be considered for all the structures located in the near-field areas. Of course, for stiffer structures, the effect of vertical component on structural forces is significant and the effect of vertical component on structural displacement can be ignored.

7. It is recommended that a vertical design response spectrum be used to calculate the vertical force due to earthquakes occurred in near-field areas.
8. Equations are developed to derive average (50%) spectrum and average plus one standard deviation (84.1%) spectrum to calculate the vertical response spectrum factor (B_v) of buildings with periods equal or less than 2.0 seconds. As the factor of irregular models is less than regular ones, it is recommended that the average (50%) spectrum and average plus one standard deviation (84.1%) spectrum can be used to calculate the vertical response spectrum factor of irregular and regular buildings respectively.

References

- [1] Papazoglou AJ, Elnashai AS (1996), "Analytical and Field evidence of the damaging effect of vertical Earthquake ground motion", *Earthquake Engineering and Structural Dynamics*, Vol. 25, PP. 1109-1137.
- [2] Kim SJ (2008), *Seismic assessment of RC structures considering vertical ground motion*, Ph.D. thesis in Civil Engineering, University of Illinois at Urbana-Champaign.
- [3] Kim SJ, Holub C and Elnashai AS (2008), "Analytical and Experimental Investigations of the Effect of Vertical Ground Motion on RC Bridge Piers", *Proceeding of 14th World Conference on Earthquake Engineering*, Beijing, China, S28-002.
- [4] Decaninni LD, Liberatore L and Mollaioli F (2002), "Response of Bare and In-filled R.C. Frames under the Effect of Horizontal and Vertical Seismic Excitation", *Proceedings of 12th European Conference on Earthquake Engineering*, London, No. 164.
- [5] Ambraseys N and Douglas J (2000), "Reappraisal of the effect of vertical ground motions on response", *ESEE*, No. 004, London, UK.
- [6] Hosseini M and Firoozi Nezamabadi M (2004), "A Study on the Effect of vertical ground acceleration on the Seismic Response of steel buildings", *Proceedings of 13th world Conference on Earthquake Engineering*, Vancouver, Canada, No. 2377.
- [7] Piolatto AJ (2009), *Structural Response Including Vertical Component of Ground Motion*, M.Sc. Thesis, Southern Illinois University Carbondale.
- [8] Diotallevi PP and Landi L (2006), "Response of Structures Subjected to Horizontal and Vertical Ground Motions", *Proceedings of the 8th U.S. National Conference on Earthquake Engineering*, California, No. 1955.
- [9] Ghobarah A and Elnashai AS (1998), "Contribution of Vertical ground motion to the damage of R/C buildings", *Proceedings of the 11th European Conference on Earthquake Engineering*, Balkema, Rotterdam, The Netherlands, ISBN 90 5410 982 3.
- [10] Hosseinzadeh N (2008), "Vertical Component Effect of Earthquake in Seismic Performance of Reinforced Concrete Bridge Piers", *Proceedings of 14th World Conference on Earthquake Engineering*, Beijing, China, 06-0050.
- [11] Memari AM, Maneetes H and Bozorgnia Y (2004), "Study

- of the Effect of Near-Source Vertical Ground Motion on Seismic Design of Precast Concrete Cladding Panels", *Architectural Engineering*, PP. 167-184.
- [12] Bozorgnia Y and Campbell KW (2004), "The Vertical to Horizontal Response Spectral ratio and tentative Procedures for developing Simplified V/H and Vertical design Spectra", *Earthquake Engineering*, Vol. 8, No.2, 175-207.
- [13] Bozorgnia Y, Mahin S A and Brady G (1998), "Vertical Response of Twelve Structures Recorded during the Northridge Earthquake", *Earthquake Spectra*, Vol. 14, No.3, PP. 411-432.
- [14] Elnashai AS and Papazoglou AJ (1997), "Procedure and Spectra for Analysis of RC Structures Subjected to Strong Vertical Earthquake Loads", *Earthquake Engineering*, Vol. 1, No.1, PP. 121-155.
- [15] Kim SJ and Elnashai AS (2009), "Characterization of shaking intensity distribution and seismic assessment of RC buildings for the Kashmir (Pakistan) earthquake of October 2005", *Engineering Structures*, Volume 31, Issue 12, PP. 2998-3015.
- [16] Gupta RK and Hutchinson GL (1994), "Horizontal and Vertical Seismic Response of Torsionally Coupled Buildings", *Engineering Structures*, Vol.16, No.1, PP. 11-24.
- [17] IBC (2005), *International building Code*
- [18] EC8 (2002), *European Standard, Design of Structures for Earthquake Resistance*.
- [19] Standard No.2800 (2005), *Iranian Code of Practice for Seismic Resistant Design of Buildings*, BHRC (Building and Housing Research Center), Tehran, Iran.
- [20] Firoozi Nezamabadi M, Moghadam AS and Hosseini M (2008), "The Effect of Vertical Component of Earthquake on Seismic Response of Torsionally Coupled Systems", *Applied Sciences*, 8(22), 4029-4039.
- [21] Firoozi Nezamabadi M (2009), *Developing of Seismic Criteria Considering the Effect of Vertical Component on Response of Torsional Structures due to Near Fault Earthquake Records*, Ph.D. Thesis, Department of Civil Engineering , Science and Research Branch, Islamic Azad University (IAU), Tehran, Iran.
- [22] OpenSees (2006), "Open System for Earthquake Engineering Simulation Software", University of California, Berkeley
- [23] Mavroeidis GP and Papageorgiou AS (2002), "Near-Source Strong Ground Motion: Characteristics and Design Issues", *Proceedings of 7th us National Conference on Earthquake Engineering*, Boston, Massachusetts, No. 0240.
- [24] Xinle L, Huijuan D and Xi Z (2007), "Engineering characteristics of near-fault vertical ground motions and their effect on the seismic response of bridges", *Earthquake Engineering and Engineering Vibration*, Vol.6, No.4, PP. 345-350.
- [25] Kianoush MR and Chen JZ (2006), "Effect of vertical acceleration on response of concrete rectangular liquid storage tanks", *Engineering Structures*, Vol.28, Issue 5, PP. 704-715.
- [26] Mavroeidis GP and Papageorgiou AS (2003), "A Mathematical Representation of Near-Fault Ground Motions", *Bulletin of the Seismological Society of America*, Vol. 93, No. 3, PP. 1099-1131.