

# Maraghe Observatory and an Effort towards Retrieval of Architectural Design of Astronomical Units

Javad Shekari Niri\*

Assistant Professor of Conservation of Historical Buildings, Faculty of Architecture, International University of Imam Khomeini, Qazvin, Iran

Received on 8/8/2014 ; Accepted on 14/2/2015

## Abstract

*Maraghe* observatory was built by such engineers as *Moayededdin Orozi* etc. under supervision of *Khaje Nasireddin Tousei* in 7<sup>th</sup> century AH. The most significant feature associated with *Maraghe* observatory is the fact that architecture is employed to achieve astronomical purposes in this site. The reason for preferring observatory by astronomers was the fact that these units are superior to wooden and metal instruments with respect to accuracy, no size limitations, etc.

Architectural design and function of astronomical units of *Maraghe* observatory site after discovery of its foundation in the course of explorations before Islamic Revolution remained unclear until recent years.

After conducting required studies and investigations, the author managed to find significant cues and after some precise comparisons, he succeeded to recover the main design and function of some astronomical units of this international center. Based on these findings these astronomical structures can reliably be rebuilt.

This research showed that every circular or polygonal building cannot be considered as an observatory. For example form and function of cemetery structures are completely different with astronomical ones. Following this research also valuable results were obtained in relation to stone architectural structures present on *Maraghe* observatory hill. In addition, claims about invention of astronomical units of *Maraghe* observatory by non-Iranian scientists are rejected and rights of Iranian scientists are rationally defended in this regard.

**Keywords:** *Maraghe* Observatory, Retrieval of Architectural Design, Astronomical Units, Circular Plans, Jaipur Observatory, Architectural Materials.

## 1. Introduction

*Maraghe* observatory site as an international research-scientific center in Iran was recovered under the soils by *Parviz Varjavand* in 1962 after several centuries. Unfortunately during explorations conducted in this site only damaged foundations of circular and squared buildings were discovered. Of course revealing of these foundations made it possible to draw the plans of these buildings and structures. Explorer of the observatory was not able to find out the complete design of the buildings because he had not sufficient information. Thus his reports on the structures of the buildings were based on his guess.

After 35 years since that event, the author sought to retrieve architectural design of circular observatory units and clarify their functions.

At last based on existing cues, an extensive research started. After conducting required comparisons with existing examples in *Jaipur* observatory of India and study and matching old figures it became possible to find out the main design of some circular units of *Maraghe* observatory (Fig. 1, 2). It is worthy to note that *Maraghe* observatory was built over 5 centuries before

indian observatories. Many observatories all over the world were built by inspiring from *Maraghe* observatory at that time.

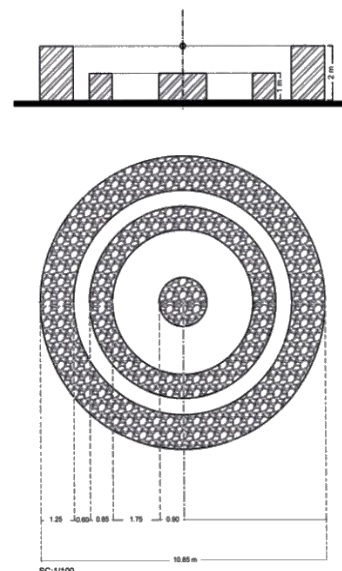

Fig. 1. Plan and cross-section of *Maraghe* observatory unit (Big Shadow instrument). Height of unit was chosen based on similar structure in *Jaipur* (design by the author).

\*Corresponding Author Email: Javadniri@yahoo.com

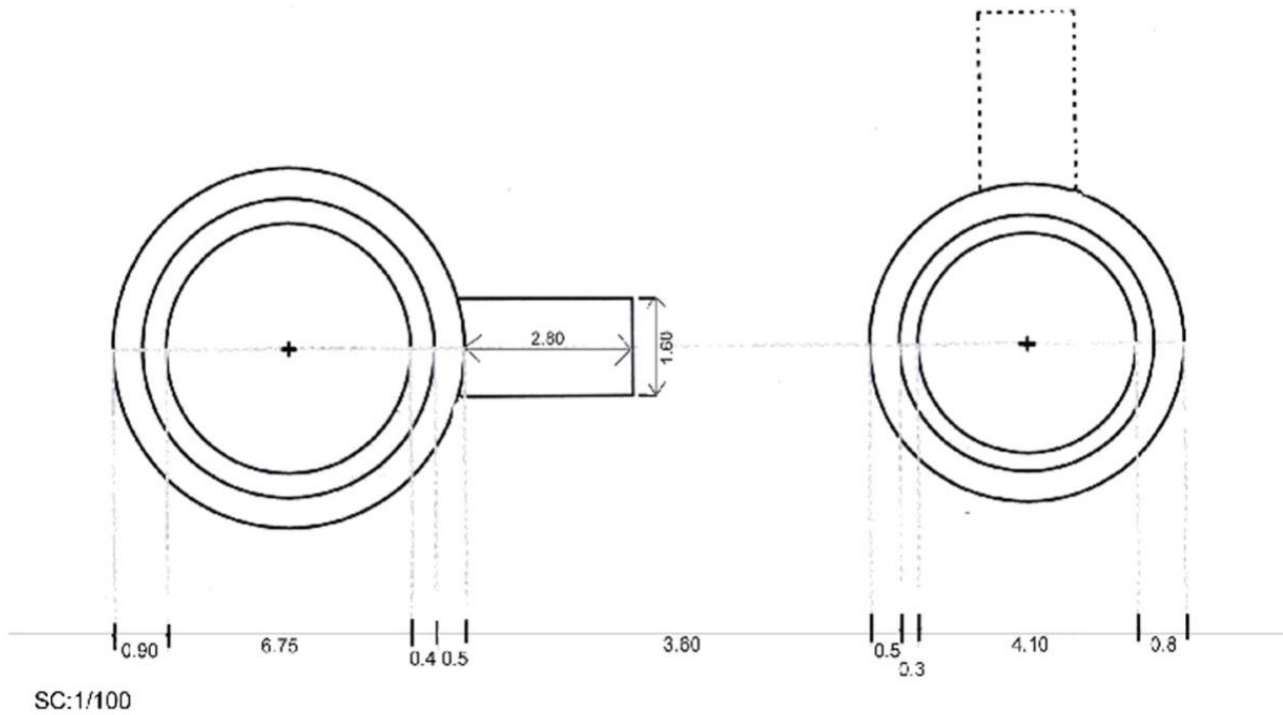

Fig. 2. Uniform circular astronomical units in *Maraghe* observatory, (Holder of two cylinders) had a function similar to Ram Yantra in *Jaipur*. (Design by the author).

Before exploration in the observatory site some people thought that architectural units on observatory hill were the same observatory and other ones also created stories about it. According to conducted research, useful information was obtained on function of most of these units and very accurate figures of them were provided for the first time. Study of their figures and designs were also resulted in interesting findings which will be provided in later sections.

Explicit evidence for greatness of this observatory is that according to historical texts, about 400000 volumes of manuscript books were hold in great library of that research-scientific institution (Tayiar Maraghi, 1986, p. 78).

## 2. Plans of astronomical units of *Maraghe* observatory discovered during scientific explorations

In historical texts there are some valuable notes about the whole architecture and scientific and astronomical activities of the observatory and also some studies were conducted on it at various times. But archeological exploration was a cornerstone for identifying architectural characteristics of astronomical units in this observatory and provided future scholars with required cues.

The main architect of the observatory is *Fakhreddin Ahmad Ebne Osman Maraghi* but responsibility of establishing scientific units was taken on *Moayiededdin*

*Orozi* who built astronomical instruments and devices of observatory (Varjavand, Parviz, 1977, p. 153). In the course of establishing observatory and building its astronomical instruments, engineers and craftsmen from various countries from Morocco to Syria and even china were involved. *Khaje Nasireddin Tousi* employed Chinese craftsmen to build observatory instruments. But an astronomer named *Al-Orozi* also involved in architectural and engineering works and supervised blacksmith's heart (Anas Khan, 1947, p. 457).

*Moayiededdin Orozi* wrote a book on the instruments and devices of *Maraghe* observatory and descriptions provided by it were used by Varjavand in design and recovery of the instruments. Orozi wrote:

"Khaje made me responsible for building that structure. Though it was not my job but I engaged in it with reluctance and because of this I was not managed to complete some instruments and devices" (Rafiei, 1985, p. 457). These honest assertions by him clearly show that professionals and engineers from various countries having expertise in the field of observatory were engaged in establishment of *Maraghe* observatory.

Combination of scientific achievements of West and East in great research institution of "Khaje Nasir" results in enhancement of human experience in the field of various sciences and techniques especially in astronomic and math and gathering of scientists from various parts of the

world led to spread of their achievements in many nations.

There are fragmented descriptions on architecture of observatory and astronomical and scientific units of it. "There was a central dome in the observatory complex which sunlight reached the inner wall of observatory through its middle sun lounge and in this way from sunrise to sunset, degrees and details of daily movement of sunlight in various hours was known and it was possible to measure sunlight height angle and determine the time in various seasons. Position of this dome and the inner gallery was in such a way that on *Norouz* day sunlight beam fell on Otbe [1]. (Saeili, 1947, 59)" (Fig. 3) Archeological explorations by *Varjavand* in 1962 revealed the plans of observatory scientific units, especially central tower and also a number of other structures of it (Fig. 3, 4, 5, 6). Their main design can largely be retrieved from these plans and in the book of "exploration of *Maraghe* observatory", some efforts were made to provide the retrieved design of some units and the central tower which revealed with a circular plan is an example for it.

After explorations in this complex, approximately 6 astronomical units with circular plans were discovered which were designed as a plan with a single circle or as homocentric plans in which the circles are tangent or separated and are in an inscribed situation. Totally 17 units of observatory complex were excavated (Fig. 4). Most of these astronomical units have stone foundations and the stones are frequently river cobble ones. Outer surface of foundations are veneered by cut stone, thus main core of foundation and wall of astronomical units are consisted of river cobble stones.

Cobble stones, if applied with weak mortar are the worst stone materials for buildings which usually are not very durable. According to explorer, the structure coverings had flat roofs which of course this assertion is not very acceptable for circular units because indeed many of them were without roofs. An enclosure wall is observed around the observatory complex. The longest part of the wall is on west side with an estimated length of 270 m. Of course this complex had a complete enclosure but over time its material has removed by local people.

Main core or central tower of observatory has a circular plan with orthogonal partitions and a vestibule along the north-south axis within it and twelve spaces are positioned on both sides of it in a symmetrical manner. It means that on each side of axis there are six spaces with various depths and in a curved form. Inner diameter of the

structure is 22m and its outer diameter is 23.6m. The wall on the stone foundation has a diameter of 80 cm. Sizes of bricks incorporated in the structure were 38×38, 18×18 and 20×20 cm. The latter size was used to cover galleries, floors as well as walls. This tower was the main center for observing space bodies and was the main center for scientific documents of the complex. The wall quarter is in the central gallery and consists of cut stone and the main observation was conducted via it. (Varjavand, Parviz, 1947, pp. 169-170). (Fig. 3)

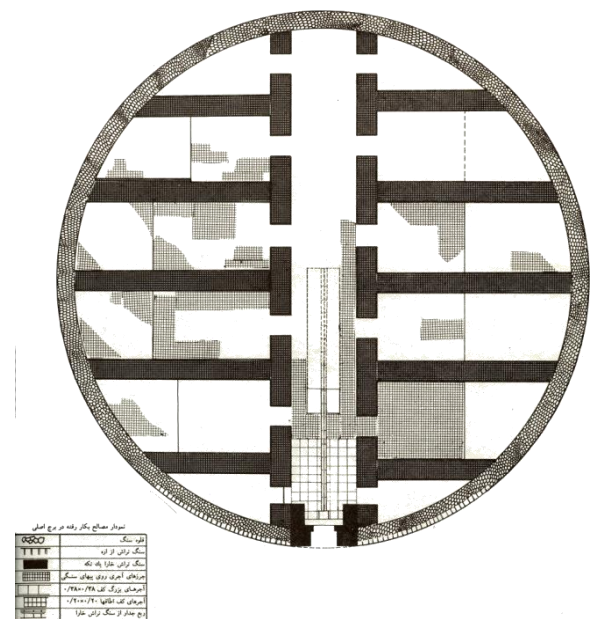

Fig. 3. Circular main tower plan of *Maraghe* observatory (from *an Exploration in Observatory*)

### 3. Some knowledge on astronomical units with circular design in *Maraghe* observatory

There are five circular units with different designs around the central tower which are mentioned in the order introduced by the explorer. These units were either a place for installing various astronomical instruments or were a means for observation of space bodies themselves and were built using architectural materials.

One of these units is on south side of the observatory. It is an enclosed and circular space in a ring form with thickness of 2.15m encapsulated by a void space with diameter of 3.30 m. On both sides of this stonework ring, two rectangular planes are connected to the ring along the same line and their sizes are 1.5×1.5m and 1.5×2 m. Total diameter of this unit is 7.60m.

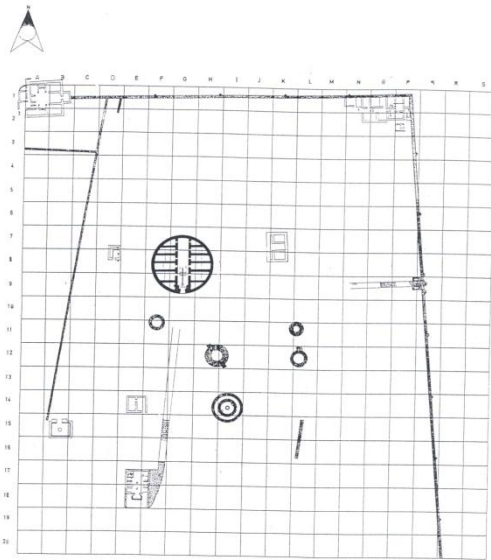

Fig. 4. Maraghe observatory site and position of its astronomical units. (from *Exploration in Observatory*)

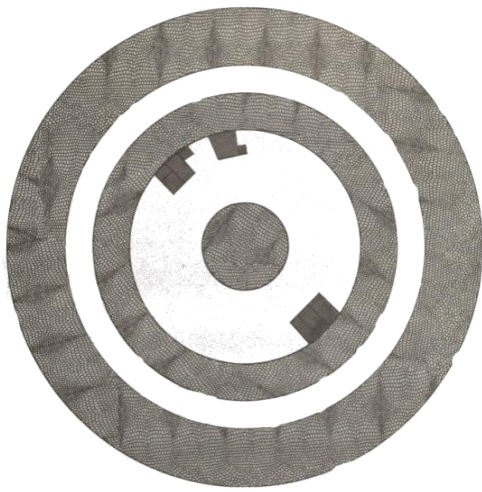

Fig. 5. plan of instrument of Digamsa Yantra of Jaipur in Maraghe observatory. (By Varjavand)

Obviously the two rectangular planes are remaining of stairs of this astronomical unit. Similar astronomical units can be observed in Jaipur observatory in India. (Fig. 4, 7)

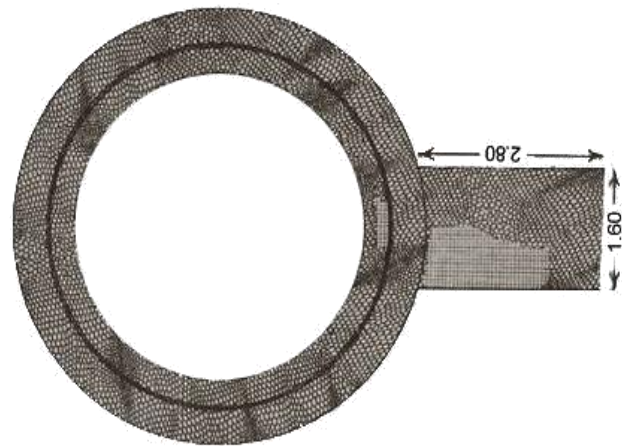

Fig. 6. A plan similar to Ram Yantra of Jaipur in Maraghe ( by Varjavand)

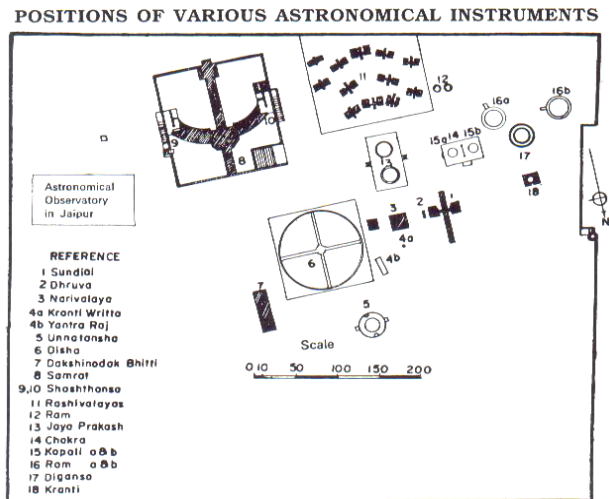

Fig. 7. Jaipur observatory site plan (from *Astronomical Ob of J.*)

Another unit is as two overlapping rings with diameter of 3.60m, with a central circle with diameter of 50cm which its outer ring is 80 cm thick. Another similar unit is placed in its neighborhood with distance of 6.75m both aligned in north-south direction and are probably connected to each other. Southern unit has diameter of 4.10 m. Thickness of inner stonework is 40 cm and that of outer one is 50 cm. Indeed they are positioned as two nested circles with different heights on a foundation with 90 cm in upper part (Fig. 2, 6). Similar to these two aligned circles can be observed in India Jaipur observatory with similar size and form and in turn function.

Though these two units were introduced separately by the explorer, but they indeed are correspondent to a similar instrument named Ram Yantra in Jaipur observatory in India. Thus figures of these two similar units should be

provided next to each other. Difference between heights of these two stonework rings is 30 cm. Southern circle has an appendix with 160×280 cm which probably was a step for climbing.

One of the astronomical units of this observatory has an interesting and complicated design. Its design consists of a central stonework circle with diameter of 1.80 m encompassed by two separate inscribed circular rings and in contrast with other designs there is nothing but void space between these two circles. In other words they consist of a solid circle and two separate inscribed rings. Diameter of this unit is 9.60 m. Diameter of its middle wall is 85 cm and diameter of its outer wall with a distance of 60 cm from the middle one is 1.25 m (Fig. 5). At last another circular unit was found with a circular stonework wall with a thickness of 70 cm. It should be noted that there are a squared room with dimensions of 4.55×4.55 m and a circular platform with diameter of 2.20 m within it. Library, casting shop and place for making astronomical tools and instruments, school and other buildings were discovered during excavation and all these units are encapsulated by a rectangular enclosure (Varjavand, 1977, pp. 169-242).

#### **4. Some circular astronomical units of Maraghe observatory and Jaipur observatory in India are similar:**

Some structures with circular plan were discovered by *Parviz Varjavand* during his excavations in *Maraghe* observatory. He only exerted effort to reconstruct the biggest circular tower or the most substantial unit of the complex. It seems that in addition to some precise speculations about the actual shape of some other structures, because of lacking required information, the excavator only provided some brief comments.

Though *Varjavand* was aware of the relations between astronomical units of *Maraghe* observatory and Indian observatory, but because of lacking sufficient documents and information about this fact he only provided some brief comments about the intact and reconstructed units of *Maraghe* observatory. Based on required cues, I decided to conduct a comparison between astronomical units of two observatory one in *Maraghe* and the other in India as possible. Fortunately after a great deal of search, I found a useful and brief book by "*Daulat Singh on Jaipur observatory*" and studied it. Then in the course of searching scientific websites, I found some extraordinary useful and clear images and documents to conduct the

mentioned comparison. One of these documents was a valuable book by *Virendra Nath Sharma*.

After extensive search in internet in relation to the intended subject, I achieved a great success in this way and they were very effective in my later research.

As previously mentioned *Ghiaseddin Jamshid Kashani* himself explained that he made some instruments of *Ologh Beig* observatory in Samarqand by study of and inspiring from those in *Maraghe* observatory (Fig. 8, 9, 10). Also observatories in china and Istanbul were built based on *Maraghe* observatory which the last one in Istanbul was established based on command of Sultan *Morad III* by well-known astronomer, master *Taqiuddin* in 1575 (Varjavand, 1977, pp. 383-390).

Observatories in India built in 17<sup>th</sup> century were established in *Dehli*, *Jaipur*, *Ujjain* (Fig. 7, 12), *Masura*, and *Banaras*, (Fig.19) [3] by a talented Indian named Maharaja *sawai Jai Singh II* (1699-1744) [4]. He built these five observatories including *Jaipur* one in 1721 (Rajavat, p. 38). One observatory has 18 astronomical units (Fig. 7) some of them are similar to ones in *Maraghe* observatory. *Maraghe* observatory can be reconstructed by careful study of these observatories based in India.

In present research in addition to analyses and explanations, one unit of *Maraghe* observatory is compared with one in *Jaipur* one because they are very similar in various aspects in such a way that one cannot distinguish between them with regard to both shape and function. Shape of the plan of this astronomical unit in *Maraghe* observatory is in the form of three nested circles which its first circle is as a solid cylinder from internal view with a diameter of 1.80 m and its full diameter is equal to 9.60 m. The distance between second and third circles (outer one) is filled with a terrace with a width of 60 cm. Width of the second circle wall is 85 cm and that of the third circle wall which is the outer circular ring is 1.25 m ( Fig. 1, 5).

This unit made me curious because of its strange shape thus I decided to obtain the plan of the structure or its recovered design (Fig. 1) and gather some information on its function. There was no sufficient information about the shape of this unit except for some speculations. Author of "Exploration in *Maraghe* observatory" wrote: 'function of this structure only can be inferred by experts in ancient astronomy. But according to specific situation of it and four platforms within it, one can guess that this unit was one of the great research sites in *Maraghe* observatory complex and was exploited for various measurements. Probably some graduated planes and instruments were

installed on those platforms. With respect to probable function of this unit it can be said that it was a place for installing magnetic rings being shifted due to solar eruptions' (Varjavand, 1977, pp. 204-205). But we should further enquire about this issue to see that whether it was possible to make such sensitive instruments at those times?

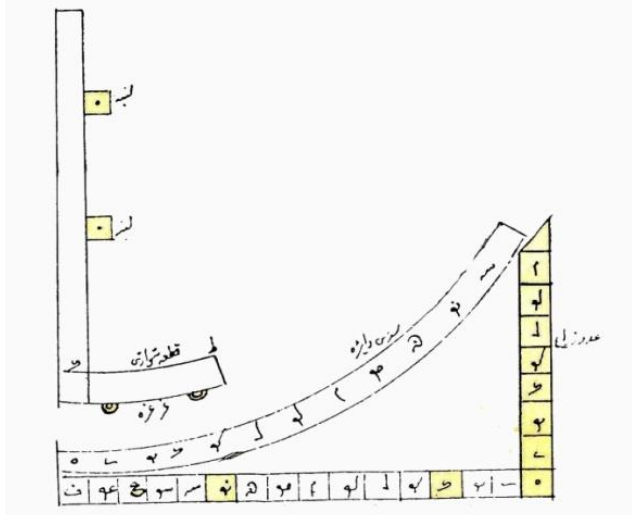

Fig. 8. *Fakhri Sixth* or circular geometrical pulpit in Samarqand observatory  
(Source: the book of "From Samarqand to Kashan".)



Fig. 9. *Fakhri Sixth* or circular geometrical pulpit in Samarqand (author's archive)

**5. A plan similar to "Digamsa Yantra" [5] of Jaipur observatory (18th century) in Maraghe (12th century)**

There is an astronomical unit in *Jaipur* observatory in the shape of three nested circles. This astronomical unit is

completely similar to an instrument in *Maraghe* observatory (Fig.11, 5). Thus it can be said that *Jaipur* observatory in completing its astronomical units imitated *Maraghe* observatory and other ones all over the world. This imitation was either direct or indirect through *Samarqand* observatory. Comparing designs and images of these two units which are thousands kilometers far from each other and there is a time interval between them which amounts to several centuries, it is clear that they are

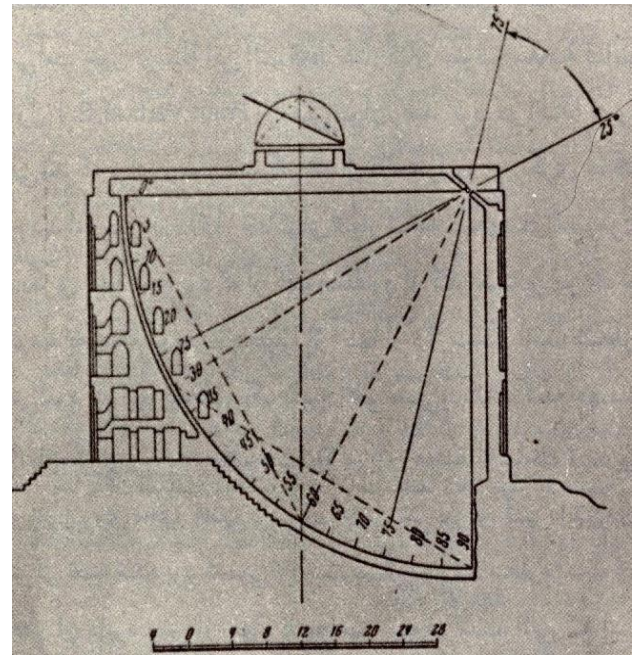

Fig. 10. Main tower of Samarqand observatory constructed based on *Maraghe* observatory (author's archive)



Fig. 11. *Digamsa Yantra* from *Jaipur* (As.Ob. of *Jaipur*)

precisely similar. It is necessary to note that *Jaipur* observatory was built between AD 1718-1724 and

building of *Maraghe* observatory began in 657 AH. Here we describe the function of this astronomical unit based on citation by *Daulat Singh*, an Indian scholar.

This astronomical building, similar to *Russian dolls*, was built in a nested form. In the middle of it, there is a column with a height of 1 m while the second circular wall inscribe it as a ring and its height is equal to that of central cylindrical column (Fig. 11).

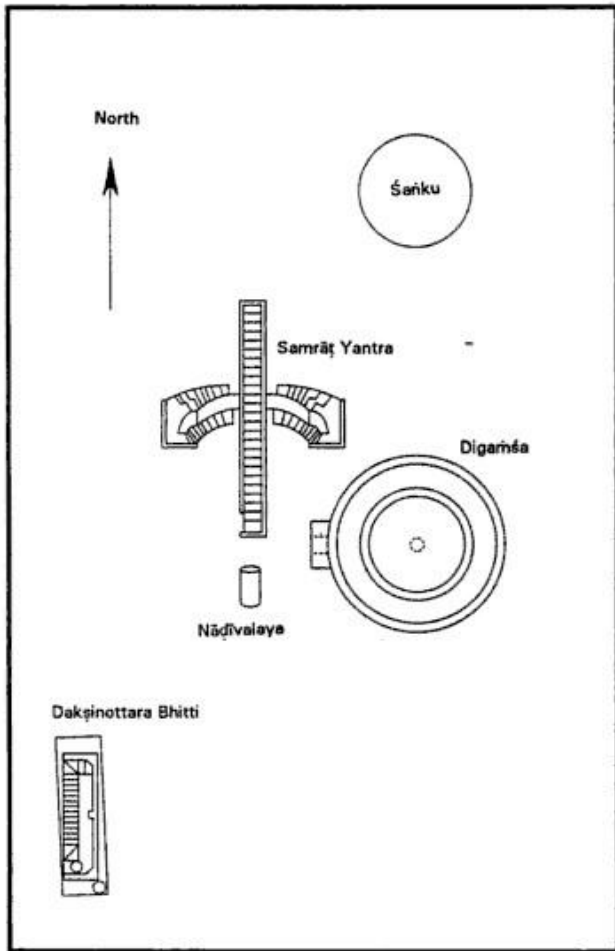

Fig. 12. Ujjain observatory site (*Virendra Nath Sharma*)

Height of the third circular wall or the outer one is 2 m and its diameter is 8 m (nearly equal to *Maraghe* unit). Horizontal surfaces of all circular elements are covered by layers of marble stone and they are graduated from 0 to 360 and all wall surfaces are covered as such.

Above mentioned degrees in turn are decimally graduated. Two strong cooper wires are extended along diagonals of outer walls from 0 to 180 degrees and 90 to 270 degrees (in such graduating systems always 0 indicates north and 180 indicates south and 90 to 270 represents west-east direction). In the middle of the above

said two wires a metal ring is placed held by them. This is a very precise instrument to show solar azimuth (horizontal circle or horizontal arch with a clockwise direction, big circle) and using a string and fixing it on the middle or axis of the central column, azimuth can be determined.

When sun rises, the shadow of circular metal ring encloses the shadow on the second circular ring. We extend the string direction up to the outer circular level emerging on the side of enclosed shadow of the ring. In this way solar azimuth is read on stone graduated layers on the third (outer) ring. Thus we can forecast sunrise and sunset, weather conditions, time and seasonal changes by dual calculations.

Also this method can be exploited for observation and calculation at night time. In this case a person rests on the second ring and looks through the metal ring. Eye direction is assumed towards the third wall. With regard to eye direction and position of it, the azimuth of intended planet is determined (*Daulat Singh*, pp. 38-39).

Obviously because of great similarity of this astronomical unit with one in *Maraghe* only a plan of it left for us, it can be said that this Indian astronomical unit was modeled by one in *Maraghe* and it is clearly inferred based on presence of such a plan in *Maraghe* with a time interval of 5 centuries and with a distance of thousands kilometers from Indian one.

In addition to *Ram Yantra* there are some other units in *Jaipur* observatory similar to those in *Maraghe* one. Presence of such a level of similarities cannot be incidental. This astronomical unit is also can be seen in *Varanasi* observatory in addition to *Jaipur* one (Fig. 13).

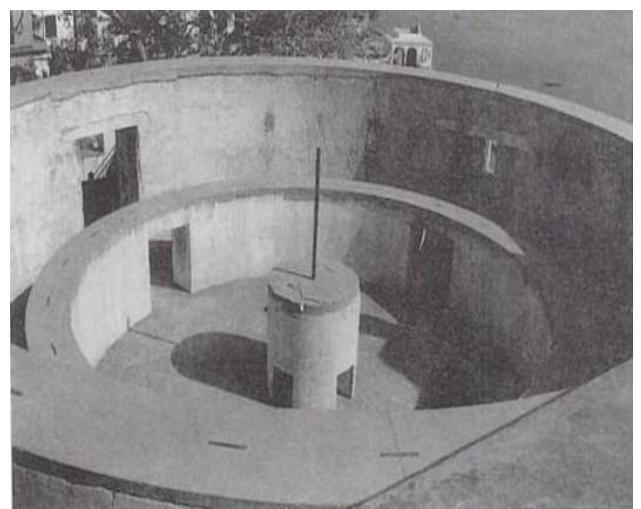

Fig.13. Varanasi observatory "Digamsa Yantra".  
(Source: *Virenda Nath Sharma*)

## 6. Tracking design of Ram Yantra in Maraghe observatory and related issues

Up to now five circular units have been discovered and identified in *Maraghe* observatory which is drawn in its general map. For two ones of these circles with identical shape and nearly equal size being established in the same direction, Varjavand presented two separate plans though he mentioned that these two circles may be identical and are related to each other (Varjavand, 1977, 200). But because of lacking required data he had no way but presenting two separate plans for them.

Studies conducted on astronomical instruments and tools of *Jaipur* observatory [8] showed that in that observatory also there are two observation instruments which are completely of the same shape and size named "Ram Yantra" (Fig. 14). These two astronomical units are complementary and have walls extended from bottom to the top and are divided into 12 parts. Their walls are connected together via a stone circular plane with a diameter same as that of the units and each unit near to itself and connected to the main circular structure has some steps so that accessibility of top level is achieved which was required to read solar indicators and required graduations. Therefore the appendix with a height of 2 m and width of 160 cm connected to south circle of *Maraghe* observatory has a plan very similar to that of Ram Yantra in *Jaipur* one and this appendix in *Maraghe* observatory is obviously the base of steps existing there at old times (Fig. 9, 14).

Considering the ability to circulate within partitions of Ram Yantra, according to Fig. 18, 12 partitions were created using triangle stones attached to the walls. There is an inverse case for the other similar astronomical instrument i.e. solid and void spaces in these two instruments are opposite to each other though their sizes and the numbers of partitions are the same. This made it possible to come in and exit from them for observation purposes. With this trick astronomic engineers succeeded to create a complete circular disc with two separate parts (Fig. 14, 17) and astronomers achieved their main goal i.e. a more precise, complete and continuous observation.

Based on the above we should explore the north circle in *Maraghe* observatory in the main explored site so that the remaining parts of the steps are discovered which their material is probably are removed as those of other architectural units.

Also we should draw their figures together not in a separate manner. With a simple comparison both with respect to the position and high level of similarity between these two instruments in architectural plan, their

structure should be assumed as their Indian peer in *Jaipur* observatory and in this way the design for reconstruction of them can be provided (Fig. 14). Therefore by identifying astronomical units and other works of *Maraghe* observatory even further and by providing complete information to various groups of public we can revolutionize visiting this valuable scientific place and make it constructive, useful and pleasant for visitors as currently is the case for other countries. With this purpose in mind, at first stone architecture of observatory hill was focused (Fig. 15, 16) and we tried to identify this great research, academic and scientific complex which at its time operated at an international level and science generated by it flowed all over the world and the significant evidence of it is currently seen from Samarqand up to China and India. Above all, we should try to revive achievements of previous generations and in this line we are responsible for introducing this great scientific work to the people of our country (Iran) and also people of other parts of the world so that inventions and innovations of our national scientists is not attributed to others.

As a result of our little information and our deficient communications, an Indian author attributes the invention of this astronomical instrument made using architectural material to Jai Singh (*Virenda Nath Sharma*, 1995, p. 80). But the fact is that several centuries before establishment of *Jaipur* observatories the original instrument had been built in *Maraghe*. Another researcher while providing some useful information repeats the previous comments in some way: "Ram Yantra is of a cylindrical shape and consists of two cylinders. The main function of it is to measure the horizontal arch placed between fixed points of space bodies in a clockwise direction. In astronomy there were no instruments similar to Ram Yantra before invention of it by Jai Singh." *Virendra Nath Sharma* explains the principles for exploiting Ram Yantra and says: 'Ram Yantra has a cylindrical structure. It is open at the top and its height is equal to its radius.' (*Sarry Perlus*, p. 1).



Fig. 14. *Jaipur* observatory. These two instruments are complementary



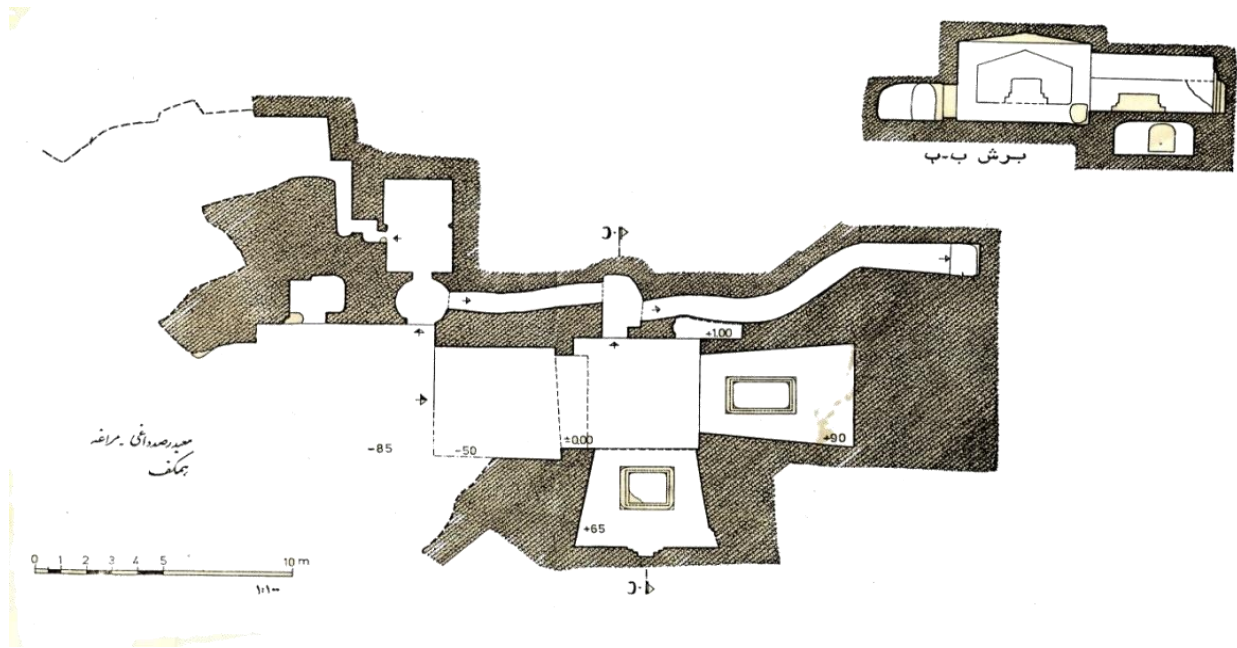

Fig. 15. Temples excavated in 'Rasad Daghi" hill related to shamanism. (Source: author)

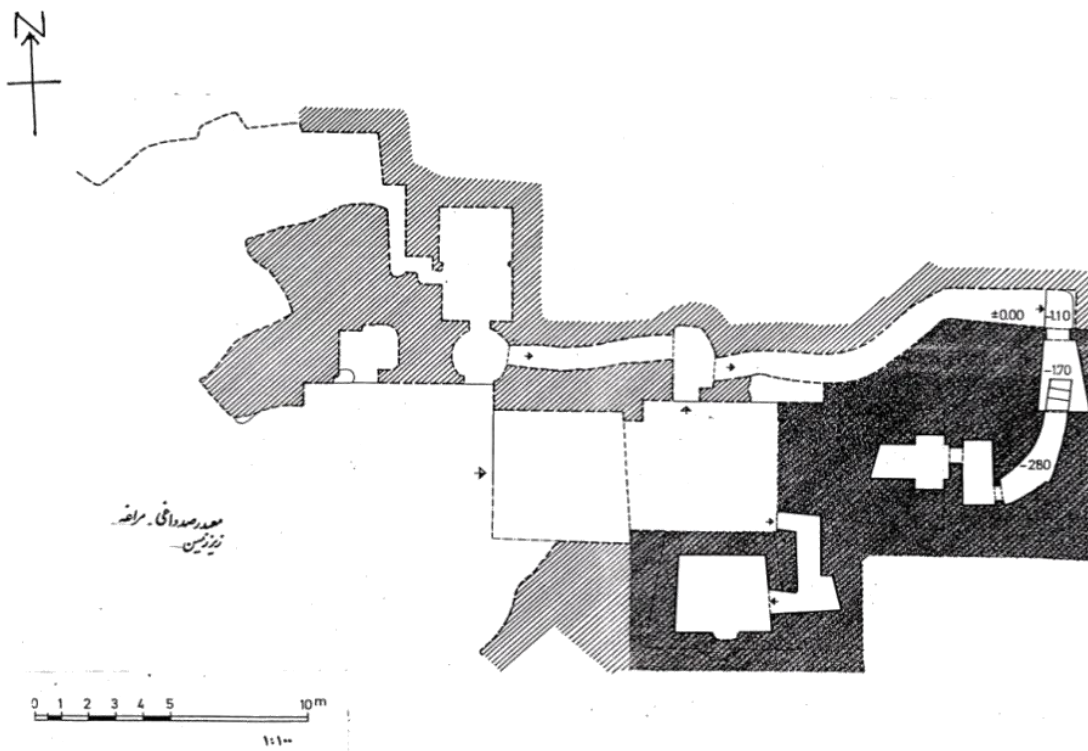

Fig. 16. Temples excavated in "Rasad Daghi" hill related to shamanism, spaces of bottom floor. (Source: author)



Fig. 17. With sunrise, indicator shadows moves on graduated planes. (Source: Daulat Singh Rajawat)

## 7. Conclusion

According to the fact that except for plan of the studied structure there were no other significant documents in order to recover and design its main building, thus this action was not taken so far. Though in writings and designs from *Ghiaseddin Kashani* some points are noted, but they are not very useful in drawing the main design of structures of the observatory. In the course of great research and studies in this respect and comparison with images from similar units from *Jaipur*, *Ujjain* and *Varanasi* (fig. 13) observatories in India, I found that plans of these units are greatly similar. Name of this unit in Indian is '*Digamsa* (or *Digansa*) *Yantra*'. Apparently it means "great observation or graduation".

According to the function of this unit it can be said that "Big shadow instrument" noted by *Orozi* is possibly the same unit.

As said previously presence of a plan similar to "*Digansa*" of *Jaipur* observatory in *Maraghe* observatory in 7<sup>th</sup> century AH shows that discovery of a similar structure in another point of the world with a distance of thousands kilometers and time interval of hundred years cannot be an incidental phenomenon. It demonstrates that *Maraghe* is the origin of this type of observatory instrument. One piece of evidence confirming this statement is that diameter of it in *Jaipur* and *Maraghe*

observatories are approximately similar (respectively 8 and 10.85 m). Height of central column and middle wall are both 1 m and for outer wall is 2 m according to its function in *Jaipur* observatory and obviously these heights should also have been similar in *Maraghe* observatory.

We have no doubts about their similarity and their function also was shown in previous sections by explanations and also using designs and images.

In this way by completing our information the main step towards identifying and designing other astronomical instruments in *Maraghe* observatory was taken. Circular surfaces of this instrument had certainly been constructed of graduated marble stone and with required scales which unfortunately was destructed over time. Fortunately its plan remained intact up to now and survived disturbances and incidents. Therefore the above valuable information guided us to reconstruct this unit in *Maraghe* observatory (Fig. 1). Also design of the unit named "*Ram Yantra*" in *Jaipur* observatory (Fig. 17, 18) was identified in *Maraghe* observatory units and same as Indian case, these two circular units in *Maraghe* observatory are related with regard to their shape and function and they were previously introduced as two separate units (Fig.2). Unfortunately this astronomical instrument was attributed to an Indian Maharaja named "*Jai Singh*" and with respect to evidence provided by us this opinion is rejected. It is probable that Iranian name for this astronomical instrument is "*Zatul Ostovanatein*" (holder of two cylinders).

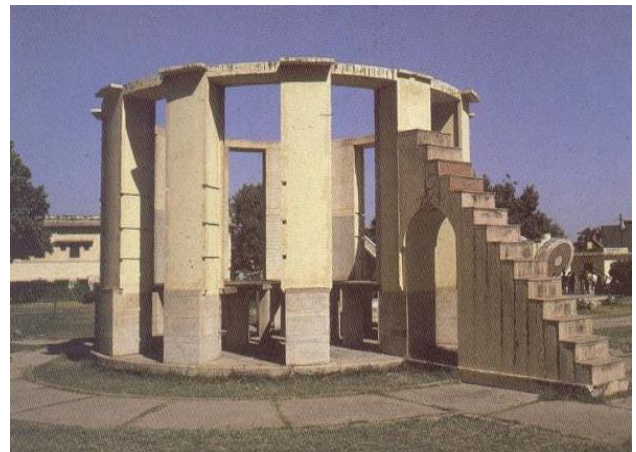

Fig. 18. Ram Yantra of Jaipur (from As. Ob. of Jaipur)

Another circular shaped instrument in *Maraghe* observatory which has two stair sets on both side and is described by Varjavand as "circular unit in the south of

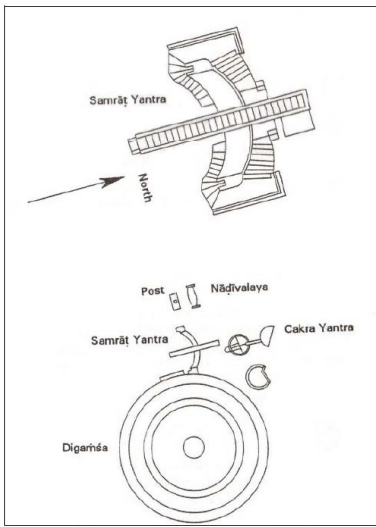

Fig. 19. Site plan of observatory, Varanasi. ( Susan N ,61. 2011.)

central tower of observatory" has a peer in *Jaipur* observatory named "*Unmatanshah Yantra*" (Fig. 4, 7). The mentioned instrument based on its function and features may have been same as "Holder of two quadrants" (*Zaturrobein*) mentioned by *Moayiededdin Orozi* which *Kashani* pointed to it by "holder of direction and height" (*Zatul-Samte-Val-Ertefae'*) because this instrument is able to do both job i.e. determination of direction and height of sun in the day and stars and planets at nights. *Kashani* pointed out to presence of this instrument in *Maraghe* observatory.

This instrument consisted of a graduated horizontal circle placed on a cylindrical wall on it two vertical graduated quadrants can move around a rod aligned with the cylinder. On each quadrant there was a pointer tool (*Azzade*) in a way that two persons was able to simultaneously determine horizontal coordinates of two space bodies (Baqeri, 1986, p. 85).

If explanations such as those mentioned above are more analyzed and assessed, scientific realities of *Maraghe* observatory are further revealed and in order to achieve this aim it is necessary to identify and find complete design for its reconstruction. With regard to the fact that in the course of excavations in *Firouzabad* in 1995 an astronomical unit was discovered, our responsibility for conducting required studies on "ancient astronomy" is highlighted.

## Endnotes

1. Othe literally means threshold or door sill.
2. According to writings by historians contemporaneous with *Khaje Nasireddin*, *Maraghe* observatory had affiliated schools either already established and were later attached to it or were constructed at *Khaje* time. *Ebne Footi*, librarian of the observatory mentions that *Moayiededdin Orozi*, one of the outstanding astronomers and engineers of the observatory, resided at "*Azyie School*" and also he pointed to "*Sadr school*". Library and observatory facilities persisted for 80 years.
3. *Delhi-Jaipur-Ujjain-Mathura·Benaras* (Varanasi)
4. Maharajah *Sawai Jai Sing*
5. *Digamsa Yantra*- according to explanations of "*Abhay Kumar Singh*", professor of *MJR Rohilkhand* university in a personal communication with author, this word is a combination of two words of *Yantra* i.e. calculation, measurement and observation and *Digamsa* i.e. big sixty graduation.
6. In book of *Daulat Singh* this is mentioned as 36 degrees which is not correct. *Ram Yantra, Unnatansh Yantra*.
7. *Jaipur* city is located at 220 km from south and west of *New Delhi* in *Rajasthan* state. It was planned and constructed as a new city around 1727 by *Jai Singh*. Architectural and planning concepts considered in their construction were very sophisticated at their own time. Observatory of the city was also one of the greatest and most excellent observatories and was located right across to royal court.

## References

- 1) Anaskhan, M., 1977. Role of Tusi in formulation, adjustment and generalization of mathematics and astronomy, Memorial of Khajeh Nasireddin Tusi, vol. 1, Tehran University press (in Persian).
- 2) Baqeri, M., 1986. From Samarqand to Kashan, Vol. 1, letters of Ghiaseddin Jamshid Kashani to his father, Vol. I, Scientific and Cultural publishing, Tehran (in Persian).
- 3) Daulat Sing, R., Astronomical Observatory of Jaipur, India: Jaipur, Dflta publications.
- 4) Habibollah, N., 1963. Shapoor library, Maraghe library, Vahid Journal, no. 3, 11<sup>th</sup> period, series 114, Tehran, pp. 272-274 (in Persian).
- 5) Rafie, A., 1985. Income of observatory and horoscope of Maraghe, book of Islamic heritage of Iran, by Rasoul Najafian, Library of Ayatollah Marashi Najafi (in Persian).
- 6) Saeili, A., 1997. Khajeh Nasireddin and Maraghe observatory, Memorial of Khajeh Nasireddin Tusi, 1<sup>th</sup> edition, Tehran University press (in Persian).
- 7) Virendra Nath Sharma, J., Singh M. B. 1995. Sawai Jai, Sing And his Astronomy. india, Delhi
- 8) Tayyar Maraghi, M., 1986. Maraghe scientific centers and schools, Journal of Miras-e-Javedan, 14<sup>th</sup> series, 4<sup>th</sup> year, no. 2, Tehran, pp. 77-78 (in Persian).
- 9) Varjavand, P., 1977. Exploration in Maraghe observatory, Amir Kabir publishing, Tehran (in Persian).
- 10) Nath Sharma, V., Sawai Jai Sing and His Astronomy, 1997, Britain, London: Cambridge University Press.
- 11) Johnson, S.R., 2011. The Spatialization of Knowledge and Power at the Astronomical Servatories of Sawai Jai Singh II, pp. 1721-1743 CE, Illinois: University of Illinois at Urbana-Champaign.

## Websites

1. <http://www.art-and-archaeology.com/india/jaipur/jan1.html>.
2. [html](#).
3. [http://www.coritour.it/foto\\_franco\\_documentazione\\_jantar\\_mantar.html](http://www.coritour.it/foto_franco_documentazione_jantar_mantar.html).
4. [http://www.jantarmantar.org/architecture\\_science\\_web.pdf](http://www.jantarmantar.org/architecture_science_web.pdf)
5. <http://www.ulugbekobservatory.parusinfo.com>
6. <http://www.anobanini.com/forum/viewtopic.php?f=37&t=1647>, The *Maragheh* Observatory by *Parvaneh* », 2014
7. [http://www.iranreview.org/content/Documents/Maragheh\\_Observatory.htm](http://www.iranreview.org/content/Documents/Maragheh_Observatory.htm), 2015 ,Iran Review.