

# Flexibility in Architecture: an Innovative Design for Covering of a Transformable Dome Using Kinetic Elements

Maziar Asefi <sup>a,\*</sup>, Soheila Aram <sup>b</sup>

<sup>a</sup> Faculty of Architecture and Urban Studies, Tabriz Islamic Art University, Tabriz, Iran.

<sup>b</sup> Tabriz Islamic Art University, lecture at University of Mohaghegh Ardabili, Iran.

Received: 25 December 2017- Accepted: 12 December 2018

## Abstract

Flexibility is a concept associated with variable needs of human beings. Today transformable structures are used to meet human changeable demands with different purposes and functions such as facades, roofs, sunshades, etc. A Flexible structure must be able to change physically and adapt to predetermined conditions. To provide flexibility and adaptability, transformable systems are required to possess appropriate covering and a proper mechanism. Given their high elasticity, membranes can be considered as the first and easiest solution, but not necessarily the best one, for such deployable structures as they may interfere with the function of the structure; so that the use of membranes in deployable structures often leads to functional, operational and visual problems which indicate the necessity of application and investigations into rigid covers for such structures. Aimed at finding a new solution to improve flexibility of transformable structures with rigid covers, this paper attempts to evaluate and assess a variety of coverings suitable for the structure proposed in this research. Being widely used, suiting various functions and having capability of design in different forms, scissor-like structures are chosen among other types of transformable systems and a design is proposed for rigid cover of scissor-hinged transformable domes. The solution for adding rigid covering involves adding additional kinetic elements to the scissor-like structure. Reciprocal elements, are connected to the structure in two directions, on which rigid covers are installed. One of the advantages of this proposal is that the elements are designed in such a way that rigid covers can be installed through various forms and configurations of modules.

**Keywords:** Transformable structures, Kinetic covering, Scissor-like structures, Transformable dome.

## 1. Introduction

To provide flexibility, architects have to consider potential needs of users during the design process (Habrackenm, 2008). Flexibility is examined in two viewpoints of the user and innovative structures and design. includes four main subjects in this regard: structural system, service spaces, architectural layout and furnishing for flexible use (Schneider & Till, 2005). This paper deals mainly with structural systems as a determinative component of flexible architecture. The structure is always considered as a permanent part of architecture that affects spatial flexibility. Transformable systems provide a solution to turn the structure into a flexible element of the architecture.

History shows that human being has never given up empirical study and scientific research about transformable systems. The configuration of systems known as transformable, deployable or kinetic structures includes a wide range of scissor-like structures, foldable plates, cable structures, tensegrities, etc. These structures are all commonly used for different purposes such as medicine, aerospace, kinetic architecture, etc. Kinetic architecture results in functional flexibility of architectural space and spatial adaptation to various climates (LUO & others, 2012:1). These systems are mostly employed for architectural design of kinetic theaters, pavilions, exhibitions and public urban spaces covering a vast area

at a low cost and high architectural quality. The pavilion designed by Pinero for an exhibition in Madrid in 1964 was an early example of deployable structure covering a large area.

Spaces enclosed by transformable structures require adequate coverage in accordance with their proper function. Due to dynamic and kinetic characteristic of the structure during the movement, the design of covering system of transformable structure must include special consideration compared to conventional structures. These coverings must be appropriately able to deploy and bear external loads and forces before, during and after transformation. Architects, such as Pinero and Salvador, sought suitable solutions to cover transformable systems in a way that the cover remained connected to the structure during expansion. This strategy eliminate one of the main weaknesses of the covering systems in their previous projects in which the cover was attached to the structure once it was completely expanded. In their following research, Pinero and Dali first succeeded in covering a foldable sculpture by 84 glass pieces (Golabchi, 2009) that it could provide a basis for innovative solutions in future studies. However, after the death of Pinero, Escrig, Sanchez, Pinero, Dali and Hoberman have studied the cover of deployable structures and mostly used membranes that were connected and simultaneously expanded with the structure.

Different proposals are put forward for the cover of

\*Corresponding author Email address: masefi@tabriziau.ac.ir

transformable systems in regard to the type of structure and deploying mechanism. Various coverings are then classified and described, among which the most suitable cover for the scissor-like structure is assessed.

## 2. Types of Covers Suitable for Transformable Structures

The selection of perfect cover for deployable structures is one of the most important parts and requirements in the design process of these systems. An appropriate classification is presented to better understand the performance of pre-attached coverings. The cover of transformable structures can be generally categorized into membrane and rigid covers:

### 2.1. Membrane cover

Membrane coverings are made of woven threads in form of fiber yarn as the main base covered with waterproof, fireproof and weather-resistant coatings (Ishii, 2000:101). PVC, PTFE and ETFE are some examples of membrane materials used in transformable structures. The most

important reasons for using membranes include:

- Being waterproof, self-cleaning and transparent
- Light weight
- Good flexibility and high foldability
- Less space required to retract the structure

Despite their benefits, membrane coverings have disadvantages such as vulnerability to external factors, decreased strength in folded parts, low thickness and vulnerability to wear and tear. Moreover, membrane materials lack proper stability and complex detailing of deployable structures does not provide flexibility in the design of covering system in terms of form and appearance. The covering can be attached internally or externally to the structure. Covers internally attached ideally suit for cold climates (Melin, 2005:66). Internally attached covers exhibit the structure and its architectural features and provide a more useful space inside the structure, while externally attached covers disturb transformation mechanism and eliminate the attractive appearance of transformable structures (Fig 1, Fig 2).



Fig 1. Position of the covering; externally installed cover(smith, 2003: 35 &Avellaneda,2013:4-5& Melin,2004:45)

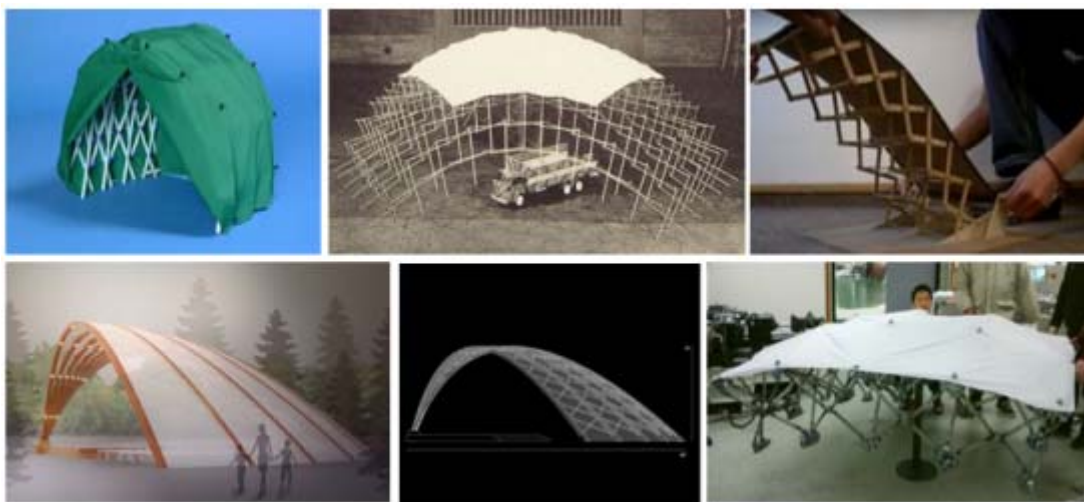

Fig. 2. Position of the covering; internally installed cover (Avellaneda,2013:2 & Park and others,2013:4 & Melin,2004:45& Friedman, 2012:22)

Membrane cover can be connected to deployable structure in different ways and the form of covering before and

after transformation of the structure depends on its connection details method of installation, the geometry of

structure and the deployment mechanism. In some cases, movement of the cover may lead to transformation of the structure and makes it deployed.

## 2.2. Rigid cover

Rigid covers of deployable structures may be made of a

variety of materials such as Plexiglas, polycarbonate, wood, steel, composite material, etc. One of the main challenges in the use of rigid material is that design and construction details should properly suit transformability of the structure and the covering material so that the covering does not interrupt with structural movements (Fig 3).



Fig. 3. Rigid cover of a deployable structure (LUO & others, 2012)

Based on their form and integrity, rigid covers are generally categorized as integrated and detached covers. The selection of each type of the covers depends on deploying mechanism of the structure and its covering materials. Origami covering can be used for these structures in an integrated form. In addition, the use of cables or other elements may improve the stability of the cover in folded parts. Detached elements can also be applied to cover the structure in accordance with its deploying mechanism where the use of embedded covering material interfere with the deployment of the whole structure.

Hoberman utilized rigid covers mounted on multi-angulated elements in his proposed transformable

structure designed for the Winter Olympics constructed in the United States in 2002 (friedman,2012:30). For a different solution P. E. Kassabian has suggested a series of rigid cover elements attached to the multi-angulated elements (Kassabian, 1999) in a manner that the cover elements neither interfere nor overlap during motion while providing a continuous, i.e. gapfree, covering surface in both the open and closed positions of the structure. Each cover is attached to a single angulated element so the motion of the structure is not inhibited. Several solutions were developed for finding optimal shape for these covers, with straight or curved inclination lines (Buhl and Jensen, 2004). (Fig 4)



Fig. 4. The Hoberman arch on the awards plaza stage in 2002 (Asefi & Ahmadnejad Karimi, 2016:62)

An example of detached rigid covers for transformable structures can be seen in a proposal presented in the paper “2D-deployable Flat Panel Structure” by Masao Takatsuka and Hiroshi Ohmori. Their model, suggested

for solar power satellites, was composed of square panels, tilted rotational axes and a scissors mechanism (Takatsuka & Ohmori, 2012:193). (Fig 5)

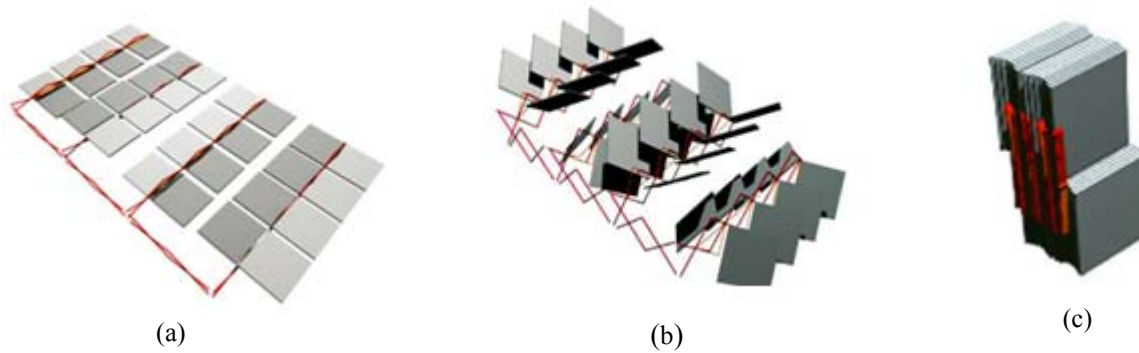
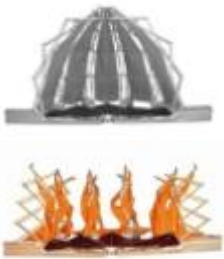



Fig. 5. 2. 2D-deployable flat-panel structure(Takatsuka & Ohmori, 2012:193);  
 (a) Scissors mast deployed ; (b) Transition ; (c) Folded

In the following table the features of different covering material types (rigid and transformable (membrane) are presented based on the examination of the built examples and the designed projects.

Table 1  
 Pros and cons of rigid and membrane covers

Type of cover		Pros	Cons
Membrane covers	Internally attached covers  	Internally attached membrane cover has a better performance in cold climates and does not interrupt transformation of the structure.  Each module can be separately retracted with its cover, requiring less space.	There is no overlap and the structure is not covered completely.  Cover does not match the structure visually.
	Integrated membrane cover  	Membrane cover is attached to lower scissors hinges and does not interrupt transformation of the structure.  When the structure is erected, the cover is adequately tensioned and does not cause visual problems.	Since the cover is attached to the structure in a slight distance, it is highly probable that cover get stuck and damaged between scissors elements and interrupt transformation of the structure.  When the structure is retracted, cover is unsuitably hung so that it may get damaged during long-term storage.
Externally attached covers	Membrane cover attached to upper scissors connections  	Given its high flexibility, membrane is used as cover in accordance with form of the structure.	It is highly probable that cover get stuck and damaged between connections and interrupt transformation of the structure.  As seen in the picture, membrane cover does not suit the structure visually and functionally.

Membrane cover attached to one part of the structure



Appropriate details of cover retraction prevents from any damages during erection of the structure and transport.

The element around which the cover is rolled can actuate deploying mechanism.

Externally attached cover is not suitable for cold climates.

The structure and covering are not integrated and there is large distance between the cover and main structure.

Rigid covers

Integrated rigid covers

Origami cover

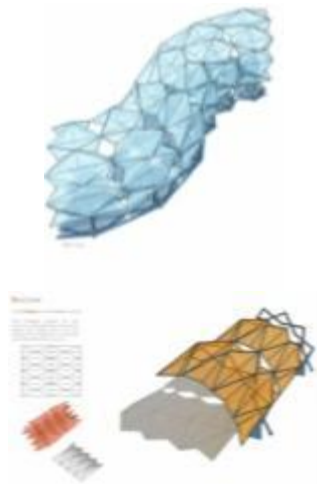

Pre-attached cover does interrupt structural movements.

Various forms can be designed by the covering attached on individual modules.

In a long term, cover may get damaged in folded parts.

There are not proper overlaps between covers of modules.

Detached rigid covers

Cover of a deployable structure designed by Hoberman for the 2002 Winter Olympics in the US

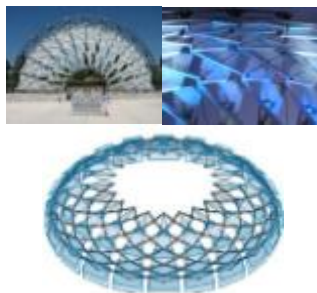

Various forms can be covered by this configuration.

Cover does not interrupt transformation of the structure.

It is possible to replace panels.

There are no overlaps between different parts.

Deployable detached rigid covers designed by Takatsaka and Ohmori for solar power satellites

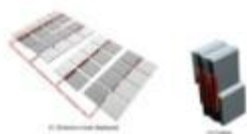

Requiring less space, cover is properly retracted with the structure. In other words, the structure can be 100% compacted.

There are no overlaps between various parts.

According to Table 1, it can be concluded that membrane covers may cause numerous problems such as improper connection to the structure leading to a gap between cover and the structure, getting stuck and damaged between structural connections during deployment and poor visual quality.

Using rigid covers have great advantages although its employment into deployable structures is challenging and require careful design consideration. Rigid covers make it possible to design a variety of fully covered deployable structures. In addition, such covers can play a structural role and contribute to the stability and durability of the structures. Based on materials selected for covering, rigid covers better provide transformable structures with advantages such as durability, self-cleaning, rapid erection, easy replacement, sound, heat and humidity insulation, fire resistance, energy efficiency, less vulnerability to the accidents and natural disasters, high

resistance to temperature change in comparison to transformable covers such as membranes.

The main advantage of using rigid covers in transformable structures is integrity to structural components so that the system can be transformed as a whole unit without any need for the addition of any other elements. However, a common problem with all structures covered by rigid panels is filling the gap between rigid covers when the structures comes to a fully open configuration especially when it is meant to be used as a fully covered structure.

To attach rigid covers to transformable structures, panels may be directly mounted on the structure or reciprocal elements may be applied as covering. reciprocal elements which do not interrupt structural transformation can eliminate the problem of overlapping in structures covered by rigid panels. In some cases, structural elements may be designed to be used as both covering material and structural elements as pictured in figure 6.

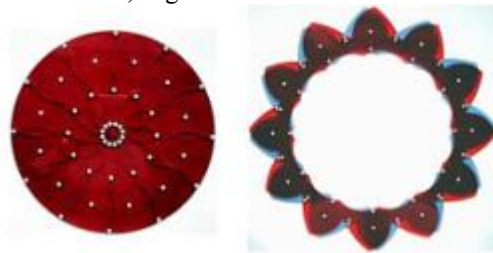

Fig. 6. Structural elements are designed in order to play the role of covers when the structure is retracted (LUO & others, 2012:2)

### 3. Architectural Features of Scissor-Like Structures

Transformable scissor-like structures are a modern system associated with kinetic architecture. The idea of scissor-like structures was pioneered by Pinero, the Spanish architect, in 1961. Pinero has provided different designs for theaters, pavilions and exhibitions using scissor-hinged elements. Each planar scissor-like structure is composed of scissor units. Each scissor unit consists of two straight bars connected by a hinge. Connecting two bars to each other at an intermediate point, with a pivotal connection, can produce a simple structural module (Asefi & Shoae, 2018:276). When this module is hinged at its endpoints to the endpoints of other elements it can provide a structure that can be transformed in to different

configurations (Asefi,2010). Scissor-like elements are divided into three main categories<sup>1</sup> according to the shape and location of the hinges. The third category includes multi-angulated elements innovated by Hobermen to create a closed scissor-hinged loop (Maden, Korkmaz & Akgun, 2011:247). Countless forms can be designed for different functions using scissor-like elements. In addition to using angulated elements, curved forms can be created by changing position of the pivot. Curved forms enhance structural efficiency and provide users with the space having more architectural capabilities (Fig 7).

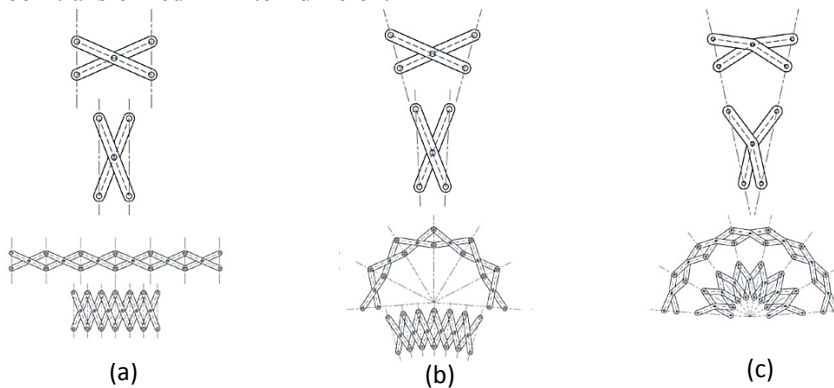

Fig. 7. Three main categories of scissor-like elements (Asefi & Ahmadnejad Karimi,2016:62)  
; (a) No curvature ; (b) Variable curvature ; (c) Constant curvature

Creating forms with curved surfaces such as arches and domes enhances structural efficiency of pantographs by increasing depth of the structure. Escrig employed a deployable scissor-hinged dome and membrane covering to design a roof for a swimming pool in Seville (Fig 8). In this project, two spherical sectors of 30 x 30 m<sup>2</sup> covered the pool. As mentioned, the membrane was combined with a deployable pantographic structure as a foldable

covering material. A fundamental challenge in the structural design of the pool was connecting two deployable pantographic domes to each other and combining membrane cover with the roof structure. Moreover, secondary elements like cables were required to control expansion/retraction of the roof and increase its stiffness during movements (Maden, Korkmaz & Akgun, 2011:247).

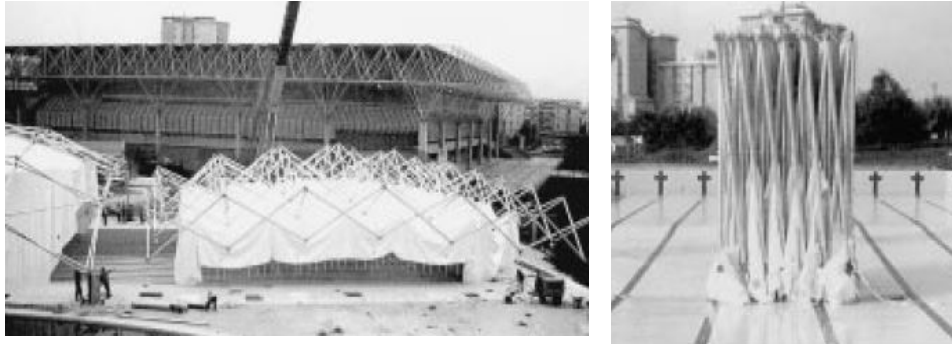

Fig. 8. Deployable membrane-pantographic structure designed by Escrig for a pool (Maden, Korkmaz & Akgun, 2011).

Given attractive advanced technology of transformable and deployable structures, it is necessary to find a covering which suits the structural capabilities. According to investigations into pros and cons of membrane and rigid covers explained earlier in this paper, it appears that rigid covers are more suitable for transformable structures. The analysis on examples explained in the literature demonstrates that rigid covers encounter with lack of overlapping and sealing the gaps between adjacent covering panels.

The rest of this paper will propose a dome-shaped transformable structures benefitting from a rigid covering panels that provide a fully enclosed space when the structure is in fully deployed configuration.

#### 4. An Innovative Solution for Rigid Covers of the Curved Scissor-Like Structure

Different steps of design process and factors affecting the final solution to achieve a suitable rigid covering for the proposed dome-shaped scissor-like structure is explained in this section. In the first step, a transformable dome with scissor-like-elements was conceived. The main design criteria including the multi-functionality, ease of erection and dismantling, transportability and the ability to support and work with rigid covering materials were considered during the design of the transformation mechanism and configuration of the whole system. Finally, a dome with 15 curved scissor module were proposed considering optimum height for users, efficient use of interior spaces and structural stability (Fig 9).

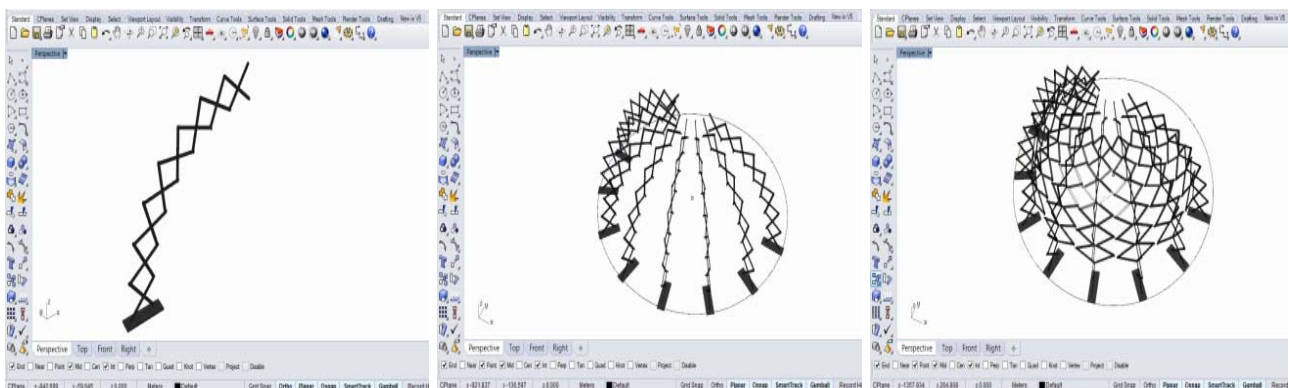

Fig. 9. Design process of scissor-like elements via Rhinoceros

In this paper, two strategies were proposed for the design of the rigid covering for the proposed transformable dome following the movement mechanisms of scissor-like-elements. The first strategy was the use of the integrated

rigid origami covers and the second method was to use the detached rigid covers. Considering the movement pattern, the integrated origami rigid cover was not suitable for the proposed design in terms of two aspects: first, given the

domical form of the structure and the transformation of the scissor-like modules, the integrated covers should be mounted on individual modules; since the modules are arranged beside each other along a circular path, the overlap of modules and the complete covering of structure were not possible. On the second hand, the overlapping of the separate cover of each scissor units does not allow the structure to be folded in a desirable compacted state. Moreover, the modules cannot be arranged properly beside each other and the elements of scissor-like modules may be exposed to extra pressure in case of a small error during the design and installation. Also, if a small piece of a rigid cover is damaged, the whole rigid cover of the module should be replaced. The detached cover is more compatible with the dome-shaped structure and does not interrupt the implementation and compaction of the form. In this case, the complete deployment of the structure is possible by correct details and it can be suitably used for shading and rain protection. If any cover is damaged, it can be easily replaced at a low cost and a longer life can be expected for the structure.

Given the detached rigid covers selected for the structure designed in this paper, the basic question is about how to install the covering on the structure to provide overlapping with no halt posed to the movement of structure. The first answer is to install the cover directly on the scissor-like structure. Given the domical form of the structure, elements type-A were considered to connect the scissor-like modules to each other. It is possible to mount rigid covers on the elements type-A by suitable design of details, so that the rigid covers were initially mounted on the structure and allow for simultaneous movement. In this case, when the covered modules are arranged beside each other, it is observed that the gap between the modules is uncovered. To solve this problem, it is not possible to connect the rigid covers on the gap between the modules to the elements type-A; because rigid covers have a considerable weight unlike the membrane covering, due to the type of material, and the installation of two covers on one member can lead to structural deformation in the element. Elements type-A allow for installation of rigid covers on the gap between the modules, so another element is required to mount a rigid cover on scissor-like modules, called the element type-B (Fig.9).

The pros and cons of application of reciprocal elements in a scissor-hinged dome are discussed below.

An advantage of this approach is the possibility of full overlapping in the rigid covering of the structure. The reciprocal elements provide suitable supports for detached rigid covers and increase the stability against lateral forces, such as winds, when attached on the both sides. The cover-to-structure connection is facilitated in terms of implementation by considering separate supports for covers of the modules and the gap between them. The installation of reciprocal elements in this way provides a rigid covering internally attached to the dome structure, which is very suitable for cold climates and also increases the readability of interior space on larger scales. Hence

the structure located outside creates an attractive view and brings a beautiful appearance to its surroundings. Another advantage of reciprocal elements for installation of covering is providing a place to mount cables on the arched scissor-like structure, which dramatically increases its stability against lateral forces, such as winds.

A disadvantage of this method is the increase in construction cost due to application of more elements. Moreover, the compatibility of scissor-like structure decreases by the addition of elements. The advantages mentioned above for this method versus its minor disadvantages justify the use of reciprocal elements for the installation of covering and the initial cost is thus reasonable due to the increased life of structure, more stability and possibility of easy and inexpensive repair of covers and reciprocal elements in the long-term. According to the contents explained previously, the details required for the responsiveness of reciprocal elements (A) and (B) are presented in the following.

To attach covering materials to the structure, reciprocal elements were designed in two forms. Elements type-A, shown in figure 9, were initially designed to arrange arches and create a dome-shaped structure. This type of elements cause that the cover could be attached internally, which suits cold climates, and the structure located outside the building could provide an attractive view and a highly perceptible indoor space. In addition to attachment of the cover, these elements were used to create places for cables which provides structural stability; in other words, the designed elements provide suitable bases for installation of cables so that each curved element could conserve its stability during implementation (Fig 10). Elements type-A are able to cover the gaps between modules when they were arranged side by side and elements type-B were designed to cover internal part of the modules. This combination makes the whole structure to be fully while covering materials are added.

Special plates were mounted on elements type-B for installation of covers and the end parts of the elements were formed in such a way that not to interrupt with structural movements after installation (Fig 11;b). In Elements type-A, the lower elements are thicker than upper ones so that the covers attached on the elements do not strike each other during structural deployment and the covers overlapped each other when the structure is expanded. Two edges are embedded on elements type-A; the internal edge for placement of covers when the structure is expanded and the external hinged edge for connection of covers between modules that could move articulately during structural movements. The elements were designed in order to control the degree of expansion/retraction of the structure. To seal the system, a special detailing is considered and designed on the covering panels to drain water as shown in figure 11;c. The detail is that the studs profile is mounted on the lower part of the cover and due to the gradient of the structure, directs the rain to the part of the elements type-B from which the rain water is harnessed (Fig11).



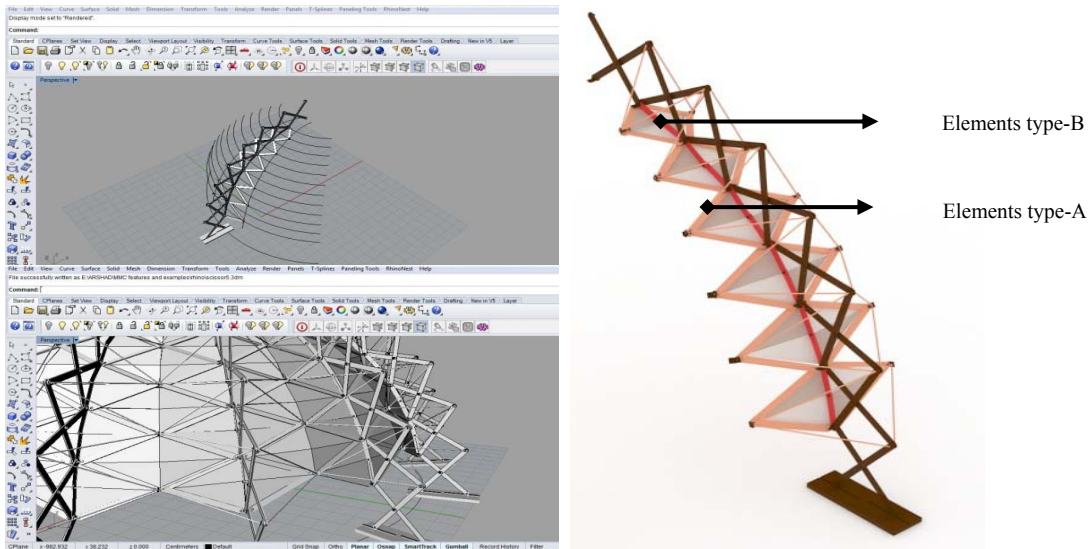

Fig. 10. Design process of elements type-A and -B via Rhinoceros ; (left) elements type-B facilitated the arrangement of modules to create a dome and provided places for attachment of covers in the gaps between modules; (right) elements type-A provided suitable places for cable installation with aim of structural stability.

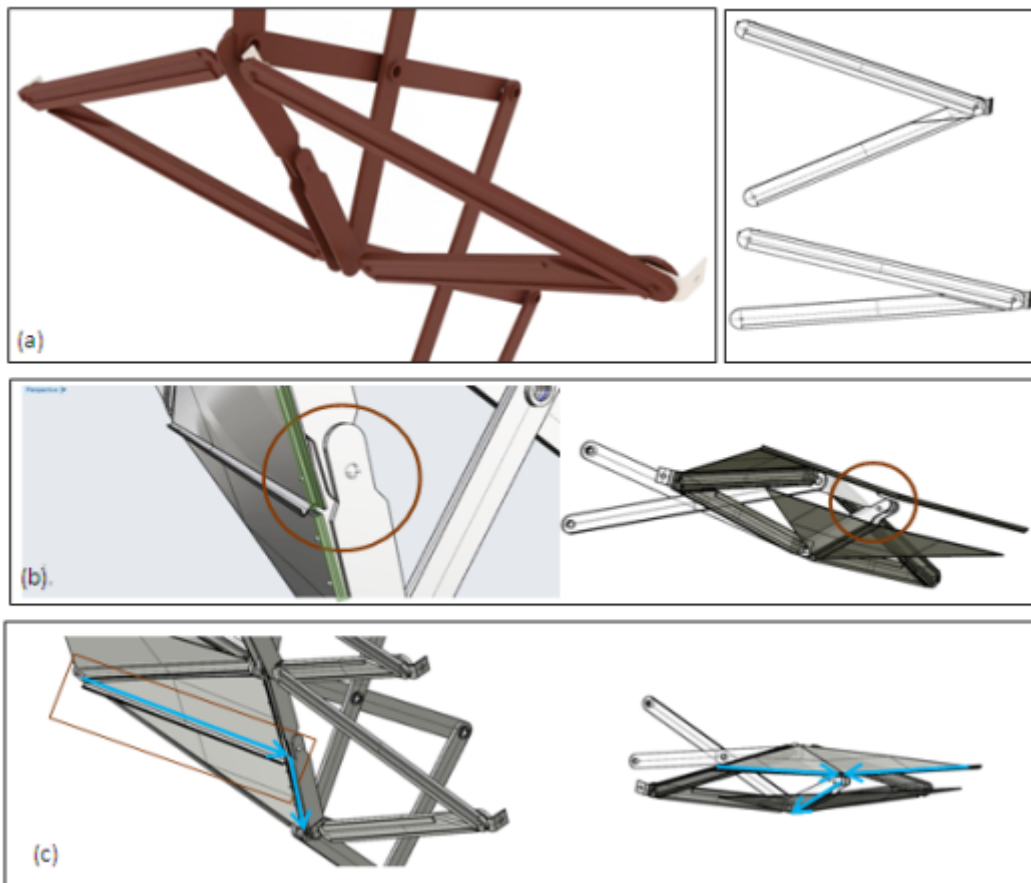

Fig. 11. Details of elements type-A and -B; (a) detail of elements type-A that shows lower elements are thicker than upper ones; (b) plates that were mounted on elements type-B and end parts of the elements were formed in such a way that not to interrupt; (c) the method of sealing.

The designed triangular covering panels are used and connected to the corresponding elements type-A or B. Using detached panels causes that the structure and covers

could easily transform together so that covers do not interrupt with structural movements (Fig 12& 13).

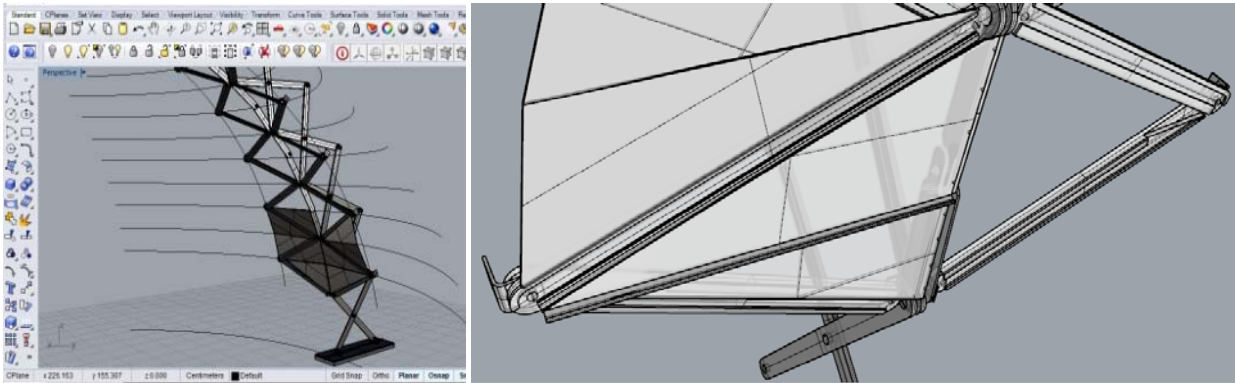

Fig. 12. Design process of elements type-A and -B via Rhinoceros ; (left) the design of covers for different parts of modules; (right) an internal triangular cover was fixed on the element type-B. It settled on the detail designed for internal edge of the element type-A when the structure was completely expanded.

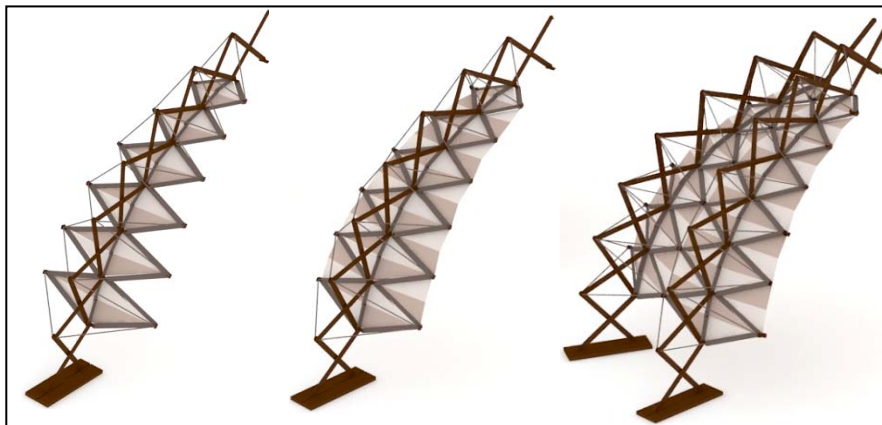

Fig. 13. Cover of elements type-A and -B for an individual module and for an arrangement of modules.

Detached panels installed on the elements cause that the structure could not be retracted completely. According to the models created by Rhinoceros, the complete structure

including covering elements covers can come to one fifth of its original configuration when the structure transforms to fully closed configuration (Fig 14).

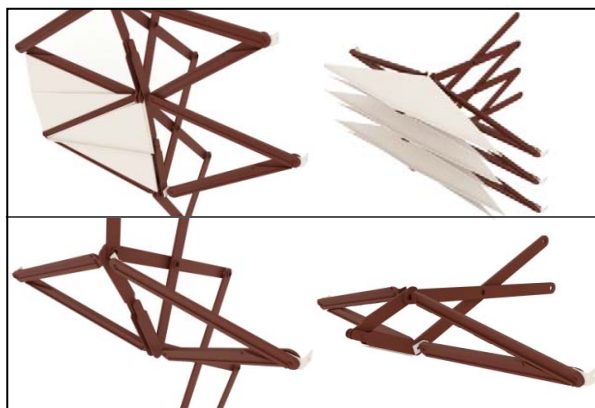

Fig. 14. Cover of elements type-A and -B in expanded and retracted status of the structure.

When the modules were designed and the structure was erected using reciprocal elements, divisions finally

emerged indicated a template for cutting the panels which could cover all parts of the spherical surface (Fig 15).

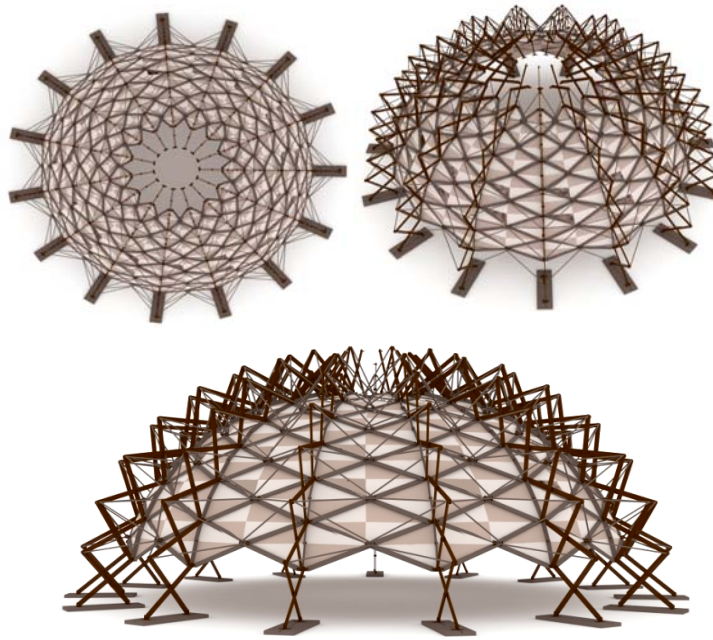

Fig. 15. Rigid covering for the scissor-like dome

The experimental test on the constructed physical model and the digital model created by Rhinoceros shows a very good performance of the covering elements and perfect arrangement of modules during movement. The result of

this paper shows that it is possible to fully cover a transformable structure employing scissor-like elements with rigid materials (Fig 16).



Fig. 16. A prototype of the model created on a scale of 1:5 via Rhinoceros

## 5. Conclusion

In this paper, an innovative solution for rigid covers of curved scissor-like structures has been proposed. A dome-shaped space has been created through the designed form, requiring accurate design and construction details for its rigid covers. In previous case studies, rigid panels could not cover whole parts of curved scissor-like structures and there were no overlaps. The difference between the present paper and previous proposals was the use of reciprocal elements connected to the scissor-like structure, on which rigid covers could be attached. These reciprocal elements were attached to the structure and to each other by angel profiles not interrupting structural movements. Rigid panels were also mounted on the elements so that internal parts of the structure were entirely covered. To construct the covering, triangular panels were fabricated

in six types optimized in accordance with scale of the structure and the cost of cutting numerous types of covers was reduced. The elements considered for attachment of covers could be generated to a variety of transformable scissor-like structures; in fact, a great advantage of this proposal was that it could be applied for various transformable planar/curved scissor-like structures. Another advantage of the proposal was the use of reciprocal elements for covering, contribution towards lateral stability of the structure and installation of cables to improve structural stability.

## References

- 1) Asefi, M., Ahmadnejad Karimi, M. (2016). Technology of Movable Architecture Theoretical and Functional Principles of Transformable Architecture, Parham Naghsh Publications, Tehran, Iran.(In persian)
- 2) Asefi, M., Shoaee, S. (2018). Proposing a Novel Kinetic Skin For Building Facades Using Scissor-Like-Element Structure, Archnet-IJAR, Volume 12, November 2018-237-238.
- 3) Asefi, M. (2010). Transformable and Kinetic Architectural Structures: Design, Evaluation and Application to intelligent Architecture.Germany: VDM Velag Publisher.
- 4) Avellaneda L, Omar, F .( 2013). Transformable Architecture Experimental Solution for a Square Mesh Deployable Cover, Proceedings of the First Conference Transformables ,In the Honor of Emilio Perez Piñero, School of Architecture Seville, Spain
- 5) Buhl T., Jensen F.V. & Pellegrino S. (2004). Shape optimization of cover plates for retractable roof structures,*Computers & Structures*, Vol. 82, pp. 1227–1236.
- 6) Chilton, J. (2009). Space grid structures, Golabchi, M., 3rd ed., Tehran: Tehran University Press.
- 7) Habraken, N. J. (2008). Design for Flexibility, *Buing Research & Information*, 290-296.
- 8) Ishii, K. (2000). Structural Design of Retractable Roof Structures, WIT Press. [John C. Chilton](#), Space Grid Structures, Architectural Press.
- 9) Kassabian P.E., You Z. & Pellegrino S.(1999). Retractable roof structures, Proceedings of Institution of Civil Engineers - Structures and Buildings, 134(1), pp.45-56.
- 10) Maden, F., Korkmaz K., Akgün Y.(2011). A review of planar scissor structural mechanisms: geometric principles and design methods, *Jornal of Architectural Science Review*, Vol. 54, pp. 246–257.
- 11) Takatsuka, M. & Ohmori, H. (2012).”Transformable Linked Panels,*International Journal of Space Structures* Vol. 27 No. 4.
- 12) Torres , Natalia P. (2013). Deployable stage design based on the application of scissor type structures, folding and membrane system, Proceedings of the International Association for Shell and Spatial Structures (IASS) Symposium.
- 13) O'Brien Melin, N. (2004). Application of Bennett Mechanisms to Long-Span Shelters, A dissertation submitted for the degree of Doctor of Philosophy in the Department of Engineering Science at the University of Oxford, Trinity Term.
- 14) Friedman, N. (2012). Investigation of highly flexible, deployable structures: review, modelling, control, experiments and application.
- 15) Park Sunkyeong, J. J. & Seungdeog, K. (2013). Mock-up Test of Deployable Structure using Meridian Grid, Proceedings of the International Association for Shell and Spatial Structures (IASS) Symposium, Beyond the limits of man 23-27 September, Wroclaw University of Technology, Poland J.B. Obrebski and R. Tarczewski (eds.)
- 16) Schneider, T., & Till, J. (2005). “Flexible Housing: The Means to the End, 287-296.
- 17) Smith, J. k. (2003). current Technologies and trends of retractable roofs, Submitted to the Department of Civil and Environmental Engineering in Partial Fulfillment of the Requirements for the Degree of Master of Engineering in Civil and Enviromental Engineering, University of Washington.
- 18) Luo, Y.Z., Wang, D.W., Mao, D.C., Liu, J.J. LIU & You, Z.(2012). Movable structures based on mechanisms, IASS.

---

<sup>i</sup> Translational, polar and angulated types